

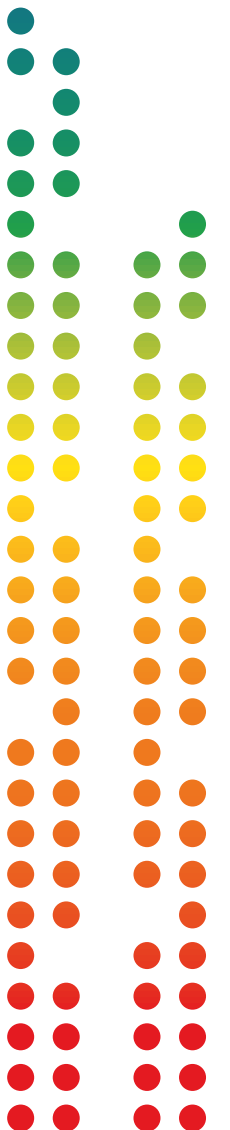

What's better than a real brand to promote yours?



2018

Writing Instruments • Sticky Notes • Notebooks • Office Accessories
Lighters & cases • Shavers • Bags • Packaging



FR / Quoi de mieux qu'une grande marque pour promouvoir la vôtre ?

Chez BIC®, nous sommes persuadés que des problématiques mondiales telles que la responsabilité sociale et le développement durable deviennent de plus en plus importantes, pour nos clients comme pour nous. Nous comprenons donc pleinement à quel point il est essentiel pour nos clients de disposer d'une marque reconnue dans le monde entier et qui partage ces valeurs, afin d'optimiser l'impact positif de leur communication sur le marché. Depuis plus de 60 ans, BIC® s'engage en faveur de l'environnement. Notre engagement sans faille envers la qualité, la fiabilité et la sécurité se manifeste dans notre souci constant d'aller toujours au-delà des normes internationales et des exigences réglementaires. En outre, nos produits emblématiques, tel que le stylo BIC® 4 Colours qui fait partie intégrante de la vie de tant d'entre nous, expliquent pourquoi la marque BIC® est reconnue par neuf personnes sur dix. Chez BIC®, nous « honorons le passé pour inventer le futur ». C'est dans cet esprit que nous poursuivons nos efforts pour proposer à nos clients les produits et les services les plus innovants et de qualité. Cette année, notre choix de marques partenaires, sélectionnées avec soin et qui partagent totalement les valeurs BIC®, complète vos produits personnalisés BIC® favoris afin de vous offrir un éventail de solutions complet pour vos besoins promotionnels. En outre, avec plus de 50 ans d'expérience en technologies d'impression, nous vous proposons une multitude de possibilités d'impression tout en couleur. Vous pouvez donc être sûr de confier votre marque à des spécialistes. En achetant BIC®, vous n'achetez pas uniquement un produit. Vous achetez de la valeur, des garanties, des émotions et des articles que les gens connaissent et apprécient. Une marque avec laquelle des générations entières ont grandi, et qui les a accompagnées à l'école, à la maison, au travail et en vacances. Une marque qui fait partie de la vie quotidienne de millions de personnes. Une marque qui a vu les enfants devenir adultes, puis vieillir, à mesure que s'écrivaient les chapitres de nos vies. C'est pourquoi la marque BIC® est idéale pour compléter la vôtre ! Nous vous remercions pour votre soutien, qui nous a permis de devenir le leader des articles promotionnels de marque. Soyez assuré de notre engagement total et de nos efforts pour développer des produits et des services qui nous permettront de devenir un partenaire encore plus performant.

En vous souhaitant le meilleur pour 2018 !

Bruno Bich
Président

ES / ¿Qué mejor que una marca para promocionar la tuya?

En BIC® creemos firmemente que asuntos como la responsabilidad social y el desarrollo sostenible son cada vez más importantes, tanto para nuestros clientes como para nosotros mismos. Es por ello que entendemos perfectamente la importancia que tiene para nuestros clientes el hecho de poder contar con una marca reconocida mundialmente que a la vez comparte estos mismos valores, optimizando así el impacto positivo de tus campañas promocionales. En BIC® hace más de 60 años que estamos comprometidos con el medio ambiente. Nuestra apuesta incondicional por la calidad, fiabilidad y seguridad se hace evidente en nuestra perseverancia en exceder los estándares y requisitos internacionales. Además, productos icónicos como el BIC® 4 Colours, que han formado parte de la vida de todos nosotros, explican por qué BIC® es una marca conocida por 9 de cada 10 personas. En BIC® "honoramos el pasado e inventamos el futuro". Es de esta manera que continuamos esforzándonos para poder proporcionar a nuestros clientes los productos más innovadores, con más calidad y con el mejor servicio. Nuestros productos Partner Brands, exclusivamente seleccionados siguiendo los mismos estándares que los productos BIC®, ofrecen variedad de soluciones para tus eventos promocionales. Además de seguir contando con más de 50 años de experiencia y de seguir ofreciendo múltiples posibilidades de impresión a todo color, puedes estar seguro que tu marca está en manos del experto. Comprando BIC® no sólo estás comprando un producto. Estás adquiriendo unos valores, unas garantías, emociones, productos reconocidos mundialmente. Una marca con la que muchas generaciones han crecido y disfrutado en la escuela, en casa, en el trabajo y en el tiempo de ocio. Una marca que ha sido parte del día a día de millones de personas, que ha acompañado a los niños durante todas las etapas de crecimiento y que sigue formando parte de sus vidas como adultos. ¡Esta es la razón por la que la marca BIC® se complementa a la perfección con la tuya!

Gracias a tu apoyo hemos conseguido ser líderes en el mercado promocional. Puedes confiar en nuestro esfuerzo y compromiso total en seguir desarrollando productos y servicios y seguir siendo tu proveedor de confianza.

¡Nuestros mejores deseos para 2018!

Bruno Bich
Director General

DE / Was kann Ihre Marke besser unterstützen als eine starke Marke?

Bei BIC® sind wir fest davon überzeugt, dass globale Themen wie soziale Verantwortung und Nachhaltigkeit sowohl für unsere Kunden als auch für uns selbst zunehmend an Bedeutung gewinnen. Deshalb verstehen wir vollkommen, wie wichtig es für Sie, unsere Kunden ist, eine weltweit anerkannte Marke, die diese Werte teilt, an Ihrer Seite zu haben. Damit Sie Ihre werbliche Kommunikation am Markt positiv unterstreichen und optimieren können. BIC® hat sich seit über 60 Jahren der ökologischen Verantwortung verpflichtet. Unser leidenschaftliches Engagement für Qualität, Zuverlässigkeit und Sicherheit zeigt sich in unserem starken Fokus darauf, stets internationale Standards und Regelungsvorschriften zu übertreffen. Auch verdeutlichen unsere ikonischen Produkte wie der BIC® 4 Colours, der ein fester Bestandteil des Lebens so vieler von uns ist, weshalb 9 von 10 Menschen die Marke BIC® kennen. Bei BIC® ehren wir die Vergangenheit und erfinden die Zukunft". Auf diesem Weg arbeiten wir fortwährend hart daran, unseren Kunden die innovativsten und qualitativ hochwertigsten Produkte und Dienstleistungen zuverlässig anzubieten. Ihre beliebten BIC®-Markenprodukte werden in diesem Jahr vervollständigt durch eine Auswahl sorgfältig selektierter Partnermarken, die völlig im Einklang mit den BIC®-Werten sind. Sie dürfen eine umfassende Auswahl an Lösungen für Ihre Werbeaktivitäten entdecken. Des Weiteren bieten wir Ihnen mit über 50-jähriger Druckerfahrung unbegrenzte Vollfarb-Druckmöglichkeiten an. Sie können sicher sein, dass Ihre Marke bei uns in den Händen von Experten ist. Wenn Sie BIC® kaufen, kaufen Sie mehr als ein Produkt. Sie erwerben Werte, Garantien und Emotionen in den Produkten, die Menschen kennen und lieben. Eine Marke, mit der Generationen aufgewachsen sind und die in Schule, zu Hause, am Arbeitsplatz und auf Reisen wertgeschätzt wird. Eine Marke, die Teil des täglichen Lebens von Millionen von Menschen ist. Eine Marke, die Kinder auf ihrem Weg zum Erwachsenwerden begleitet hat und ihnen auch heute in allen Lebensphasen zur Seite steht. Deshalb verkörpert die Marke BIC® die idealen Eigenschaften, um Ihre Marke zu vervollständigen! Vielen Dank für Ihre Unterstützung, mit der wir zur führenden Marke für Werbeartikel geworden sind. Sie können darauf vertrauen, dass wir unser ganzes Engagement und unseren vollen Einsatz darauf richten, Produkte und Dienstleistungen zu entwickeln, durch die wir ein immer noch besserer Partner werden.

Allerbeste Grüße und die besten Wünsche für 2018!

Bruno Bich
Chairman

IT / Cosa c'è di meglio di un vero marchio per promuovere il tuo?

In BIC® crediamo fermamente che le questioni globali quali responsabilità sociale e sviluppo sostenibile siano sempre più sentite, tanto dai nostri clienti quanto da noi stessi. Pertanto, comprendiamo pienamente l'importanza per i nostri clienti di avere un marchio riconosciuto a livello globale che rispecchi questi valori, in modo da ottimizzare l'impatto positivo della loro comunicazione sul mercato. BIC® ha dimostrato il proprio impegno nell'ambito della responsabilità sociale per oltre 60 anni. La nostra incommensurabile dedizione verso qualità, affidabilità e sicurezza è evidente nell'ossessiva ricerca di superare costantemente gli standard internazionali e i requisiti normativi. Inoltre, i nostri emblematici prodotti, come BIC® 4 Colours, che è stato parte integrante delle vite di moltissimi di noi, spiegano il motivo per il quale il marchio BIC® sia riconosciuto da 9 persone su 10. In BIC®, il nostro motto è "Onora il passato, inventa il futuro". In questo modo, continuiamo a lavorare sodo per assicurarci di offrire ai nostri clienti i prodotti e i servizi più innovativi e qualitativamente migliori. Quest'anno, la nostra gamma di marchi partner, accuratamente selezionati e perfettamente in linea con i valori BIC®, aggiunge prestigio ai vostri prodotti a marchio BIC® preferiti offrendovi un ventaglio completo di soluzioni per qualsiasi esigenza promozionale. Per di più, grazie agli oltre 50 anni di esperienza nella stampa e all'offerta di infinite possibilità di stampa a colori, potete essere sicuri di affidare i vostri marchi in mano a esperti. Acquistando BIC® non acquistate solo un prodotto. Acquistate valori, garanzie ed emozioni, prodotti che la gente conosce e ama. Un marchio con il quale sono cresciute generazioni e che è stato apprezzato a scuola, a casa, al lavoro e in vacanza. Un marchio che ha fatto parte della vita quotidiana di miliardi di persone. Un marchio che ha accompagnato i bambini fino alla maturità e oltre, durante tutti i capitoli delle loro vite. È per questo che il marchio BIC® ha le caratteristiche perfette per dare ancora più valore al vostro! Vi ringraziamo per il sostegno che ci ha permesso di diventare il leader dei prodotti promozionali di marca. Vogliamo assicurarvi il nostro totale impegno e sforzo nello sviluppo di prodotti e servizi, al fine di diventare un partner sempre migliore.

Cordiali saluti e un augurio speciale per il 2018!

Bruno Bich
Presidente

What's better than a real brand to promote yours?

At BIC® we firmly believe that **global issues** such as **social responsibility** and **sustainable development** are **increasingly important** to both our customers and ourselves. Therefore, we fully understand the importance for our customers to have a worldwide recognised brand that shares these values, to optimise the positive impact of their communications in the market.

BIC® has been committed to environmental responsibility for over 60 years. Our unflinching dedication to quality, reliability and safety is evident in our obsession to constantly exceed international standards and regulation requirements. Furthermore, our **iconic products**, such as the **BIC® 4 Colours**, which have been an **integral part of the lives of so many of us**, explain why the BIC® brand is **recognised by 9 out of 10 people**.

At BIC®, we "Honour the past, invent the future". In this way, we continue to work hard at ensuring we bring to our customers the most innovative and qualitative products and services. This year, our range of carefully selected Partner Brands, which are fully aligned with the BIC® values, complements your favourite BIC® branded products, to offer you a comprehensive range of solutions for your promotional needs. Furthermore, with over **50 years of printing experience**, offering you limitless full-colour printing possibilities, you can be confident that your brands are in the **hands of the expert**.

Buying BIC® you don't just buy a product. You buy **values, guarantees, and emotions**, products that people know and love. A brand that generations have grown up with and **cherished at school, at home, at work and on holiday**. A brand that has been a part of the **everyday life of millions**. A brand that has accompanied children growing into adults and beyond, throughout all the chapters of our lives.

This is why the **BIC® brand has the perfect attributes to complement yours!**

Thank you for your support that has led us to become the leader of branded promotional products. Please be assured of our full commitment and efforts to develop products and services to become an even better partner.

Kind Regards and all the best for 2018!



Bruno Bich
Chairman

Table of contents

BIC® WRITING INSTRUMENTS

BALLPENS - 26
METALLIC PENS - 98
ROLLERS & GELS - 108
HIGHLIGHTERS & MARKERS - 116
PENCILS - 124
COLOURING PENS - 132
CORRECTION - 140

OTHER WRITING INSTRUMENTS

PLASTIC PENS - 142
STYLUS PENS - 149

SPROUT™

SPROUT™ PENCIL - 152

BIC® STICKY NOTES

ADHESIVE NOTEPADS - 156
BOOKLETS - 166
SCRATCH PAD - 176

BIC® NOTEBOOKS

PU COVER NOTEBOOKS - 180
PLASTIC COVER NOTEBOOKS - 182
CHIPBOARD COVER NOTEBOOKS - 184

OFFICE ACCESSORIES

MOUSE PAD - 187
MUGS - 188

BIC® LIGHTERS & CASES

LIGHTERS - 200
LIGHTER CASES - 218
OTHER PRODUCTS - 225

BIC® SHAVERS

FOR MEN - 228
FOR WOMEN - 232

BIC® BAGS

BACKPACKS - 239
ACCESSORIES - 241

T'nB®

EARPHONES - 244
HEADPHONES - 247
SPEAKERS - 253
MULTIMEDIA - 257
PHONE ACCESSORIES - 261
CAMERAS - 264

SKROSS®

TRAVEL ADAPTERS - 266

BIC® PACKAGING

WRITING INSTRUMENT SPECIAL PACKAGING - 274
LIGHTER SPECIAL PACKAGING - 280

GENERAL INFORMATION

GENERAL INFORMATION - 282
STICKY NOTES GENERAL INFORMATION - 284
SYMBOLS & ABBREVIATIONS - 287
PRODUCT INDEX - 288
COLOUR TABLE - 289

FR / Nos avantages

- **MARQUE BIC®**
Votre nom sera associé à des produits de qualité. La marque BIC® est reconnue par 9 personnes sur 10 !
- **INNOVATION**
- **EXPERTISE EN MATIÈRE D'IMPRESSION**
Plus de 50 années d'expérience dans le domaine de l'impression.
- **MIX&MATCH**
Plus de 10.000 combinaisons de couleurs GRATUITES pour les composants standard !
- **MONDE EN LIGNE**
www.bicgraphic.eu
- **CERTIFICATIONS ISO 9001 ET ISO 14001**
par Lloyd's Register, relatives aux systèmes de gestion intégrée pour les installations de Tarragone (Espagne).
- **GRATUIT !**
- Coûts de préparation
- Échantillons virtuels
- Conception graphique
- Échantillons physiques
- Etc.
- **GARANTIE STOCK**
Des centaines d'articles toujours en stock.
- **SERVICE D'IMPRESSION EN 48 HEURES GRATUIT !**
Plus de 100 produits !

ES / Nuestras ventajas

- **MARCA BIC®**
Tu nombre estará asociado a productos de calidad. La marca BIC® es reconocida por 9 de cada 10 personas.
- **INNOVACIÓN**
- **EXPERIENCIA EN IMPRESIÓN**
Más de 50 años de experiencia en impresión.
- **MIX&MATCH**
Más de 10.000 combinaciones de colores GRATUITAS para componentes estándar.
- **MUNDO ONLINE**
www.bicgraphic.eu
- **CERTIFICACIONES ISO 9001 - ISO 14001**
de Sistemas Integrados de Gestión para las instalaciones de Tarragona, por Lloyd's Register.
- **¡GRATIS!**
- Gastos fijos de impresión
- Muestras virtuales
- Artes gráficas
- Muestras físicas
- Y mucho más...
- **PROMESA DE INVENTARIO**
Cientos de artículos siempre en stock.
- **¡SERVICIO DE IMPRESIÓN EN 48 HORAS GRATIS!**
¡En más de 100 productos!

DE / Unsere vorteile

- **BIC®-MARKE**
Ihr Name wird mit Qualitätsprodukten assoziiert. 9 von 10 Personen kennen die Marke BIC®.
- **INNOVATION**
- **ERFAHRUNG IN DRUCKTECHNIKEN.**
Über 50 Jahre Erfahrung im Drucken.
- **MIX&MATCH**
Über 10.000 kostenlose Farbkombinationen bei den Standardkomponenten!
- **ONLINE-WELT**
www.bicgraphic.eu
- **ISO 9001 - ISO 14001 ZERTIFIZIERUNGEN**
für integrierte Qualitäts- und Umweltmanagementsysteme für ihre Werke in Tarragona (Spanien) vom Lloyd's Register erhalten.
- **KOSTENLOS!**
- Druckeinrichtungskosten
- Virtuelle Muster
- Graphik und Design
- Materialmuster
- Und vieles andere mehr...
- **LAGERBESTANDS-VERSPRECHEN**
Hunderte von Artikeln immer am Lager.
- **48-STUNDEN-DRUCKSERVICE KOSTENLOS!**
Für über 100 Produkte!

IT / I nostri benefici

- **MARCHIO BIC®**
Il tuo nome sarà associato a prodotti di altissima qualità. Il marchio BIC® è riconosciuto da 9 persone su 10.
- **INNOVAZIONE**
- **COMPETENZA NELLA STAMPA**
Oltre 50 anni di esperienza nella stampa.
- **MIX&MATCH**
Oltre 10.000 combinazioni di colori GRATUITE per i componenti!
- **MONDO ONLINE**
www.bicgraphic.eu
- **CERTIFICAZIONI ISO 9001 - ISO 14001**
da Lloyd's Register, al Sistema di Gestione Integrato per gli stabilimenti di Tarragona (Spagna).
- **GRATIS!**
- Costi d'impianto
- Campioni virtuali
- Bozza grafica
- Campioni fisici
- E altro ancora...
- **SICUREZZA DI INVENTARIO**
Centinaia di articoli sempre disponibili.
- **SERVIZIO DI STAMPA IN 48 ORE GRATIS!**
Oltre 100 prodotti!

Our advantages



BIC® BRAND

Your name will be associated with quality products. **The BIC® brand is recognised by 9 out of 10 people**



INNOVATION

Manufactured and printed in EUROPE



PRINTING EXPERTISE

Over **50 years of printing** expertise



ONLINE WORLD

www.bicgraphic.eu



MIX & MATCH

OVER 10,000 FREE standard component colour combinations!



ISO 9001 - ISO 14001

Integrated Management System Certifications for the Tarragona facilities from Lloyd's Register



/ Set up charges
/ Visuals
/ Artwork proofs
/ Physical samples
/ And much more...



INVENTORY PROMISE

Hundreds of items **always** in stock.



FREE 48H PRINTING SERVICE!

For over 100 products!

FR / Marque

- Nous offrons des choix simples, inventifs et fiables pour tous, partout, à tout moment.
- Chiffres clés
18,9 millions de produits de papeterie
4,2 millions de briquets
7,1 millions de rasoirs
0,7 million d'autres produits

CHIFFRES D'AFFAIRES 2016 PAR CATEGORIE (en pourcentage)

30,9 millions de produits du Groupe BIC sont achetés chaque jour⁽¹⁾ à travers le monde.
(1) BASE DE 365 JOURS

- **En achetant BIC®, vous n'achetez pas uniquement un produit.** Vous achetez de la valeur, des garanties, des émotions et des articles que les gens connaissent et apprécient. Une marque avec laquelle des générations entières ont grandi, et qui les a accompagnées à l'école, à la maison, au travail et en vacances. Une marque qui fait partie de la vie quotidienne de millions de personnes. Une marque qui a vu les enfants devenir adultes, puis vieillir, à mesure que s'écrivaient les chapitres de nos vies.
- Pour la première fois.
Et ensuite pour toujours.

ES / Marca

- Ofrecemos productos simples, ingeniosos y fiables para todo el mundo, en todo el mundo y en cualquier momento.
- Cifras clave
18,9 millones de productos de papelería
4,2 millones de encendedores
7,1 millones de maquinillas de afeitar
0,7 millones de otros productos

VENTAS NETAS 2016 POR CATEGORÍAS (en porcentaje)

30,9 millones de productos del grupo BIC son comprados todos los días⁽¹⁾ en todo el mundo.
(1) BASE 365 DÍAS

- **Comprando BIC® no sólo estás comprando un producto.** Estás adquiriendo unos valores, unas garantías, emociones, productos reconocidos mundialmente. Una marca con la que muchas generaciones han crecido y disfrutado en la escuela, en casa, en el trabajo y en el tiempo de ocio. Una marca que ha sido parte del día a día de millones de personas, que ha acompañado a los niños durante todas las etapas de crecimiento y que sigue formando parte de sus vidas como adultos.
- Por primera vez.
Y para siempre.

DE / -Marke

- Wir bieten einfache, innovative und verlässliche Lösungen für Jeden, an jedem Ort, zu jeder Zeit.
- Kennzahlen
18,9 Millionen Papeterie-Produkte
4,2 Millionen Feuerzeuge
7,1 Millionen Rasierer
0,7 Millionen weitere Produkte

NETTOUMSATZ 2016 PRO GESCHÄFTSFELD (in Prozent)

30,9 Millionen Produkte der BIC Gruppe werden täglich⁽¹⁾ weltweit gekauft.
(1) BASIS 365 TAGE

- **Wenn Sie BIC® kaufen, kaufen Sie mehr als ein Produkt.** Sie erwerben Werte, Garantien und Emotionen in den Produkten, die Menschen kennen und lieben. Eine Marke, mit der Generationen aufgewachsen sind und die in Schule, zu Hause, am Arbeitsplatz und auf Reisen wertgeschätzt wird. Eine Marke, die Teil des täglichen Lebens von Millionen von Menschen ist. Eine Marke, die Kinder auf ihrem Weg zum Erwachsenwerden begleitet hat und ihnen auch heute in allen Lebensphasen zur Seite steht.
- Zum ersten Mal.
Und immer wieder.

IT / Marchio

- Offriamo prodotti semplici, ingegnosi ed affidabili per chiunque, ovunque e in ogni momento.
- Cifre chiave
18,9 milioni di prodotti di cancelleria
4,2 milioni di accendini
7,1 milioni di rasoi
0,7 milioni di altri prodotti

VENDITE NETTE 2016 PER CATEGORIA (in percentuale)

30,9 milioni di prodotti del gruppo BIC sono comprati ogni giorno⁽¹⁾ in tutto il mondo.
(1) BASE 365 GIORNI

- **Acquistando BIC® non acquistate solo un prodotto.** Acquistate valori, garanzie ed emozioni, prodotti che la gente conosce e ama. Un marchio con il quale sono cresciute generazioni e che è stato apprezzato a scuola, a casa, al lavoro e in vacanza. Un marchio che ha fatto parte della vita quotidiana di miliardi di persone. Un marchio che ha accompagnato i bambini fino alla maturità e oltre, durante tutti i capitoli delle loro vite.
- Per la prima volta.
E per sempre.



We offer simple, inventive and reliable choices for everyone, everywhere, every time.

Key figures

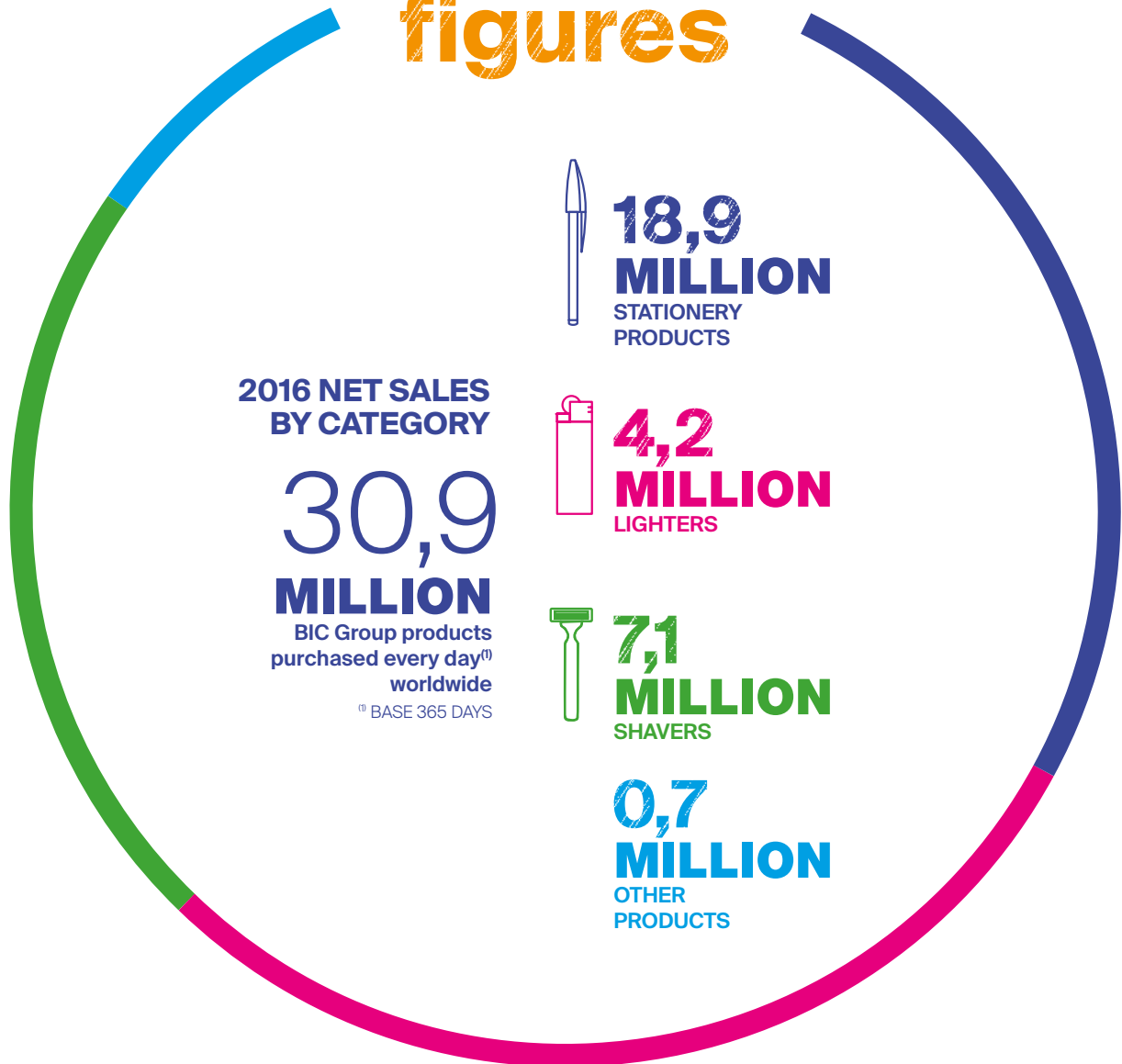

Buying BIC® you don't just buy a product. You buy values, guarantees, and emotions, products that people know and love. A brand that generations have grown up with and cherished at school, at home, at work and on holiday. A brand that has been a part of the everyday life of millions. A brand that has accompanied children growing into adults and beyond, throughout all the chapters of our lives.

⋮ For the first time.
⋮ **And forever after.**

FR / Marque

- Près de vous.
- BIC® est toujours proche de vous. Publicités classiques, Cross-marketing, Visibilité en magasin, visibilité dans les commerces, campagnes médiatiques Digitales et Sociales innovantes... La marque BIC® est toujours présente dans l'esprit de vos clients.
- **Les campagnes et événements** offrent de nouvelles et originales manières d'être connecté avec les consommateurs BIC®.
- BIC® a lancé BIC® SHAVE CLUB, son service de **souscription en ligne** avec un rasoir rechargeable BIC® pour homme, en débutant par la France et l'Angleterre.
- BIC® a lancé son **premier site internet d'e-commerce Direct** consommateur en Europe pour une édition limitée de stylos BIC® 4 couleurs!
- Partenaire historique de la fameuse compétition cycliste, BIC® va, une nouvelle fois, voyager sur les routes de France. Une opportunité unique pour rencontrer ses consommateurs.

ES / Marca

- Cerca de ti.
- BIC® siempre está cerca. Anuncios clásicos, Cross-Marketing, visibilidad en la tienda, visibilidad comercial, campañas innovadoras de medios digitales y redes sociales... La marca BIC® siempre está presente en la mente de tus clientes.
- **Las campañas y los eventos** ofrecen formas nuevas y originales de conectar con los consumidores de BIC®.
- BIC® lanza BIC® SHAVE CLUB, **su servicio de suscripción online** con una máquina de afeitar recargable BIC® para hombres en Francia y en Reino Unido.
- ¡BIC® lanza su **primer sitio web de comercio electrónico directo** al consumidor en Europa para bolígrafos BIC® 4 Colours Limited Edition!
- Socio histórico de la famosa competición de ciclismo, BIC® volverá -este año de nuevo- a cruzar las carreteras de Francia. Una oportunidad única para encontrarse con sus consumidores.

DE / -Marke

- In Ihrer Nähe.
- BIC® ist immer präsent. Klassische Werbung, Cross-Marketing, Sichtbarkeit im Regal, Präsenz im Handel, Innovative Digitale & Social Media Kampagnen... Die Marke BIC® ist immer in den Köpfen Ihrer Kunden.
- **Kampagnen und Events** bieten neue, originelle Wege, mit BIC®-Konsumenten in Verbindung zu treten..
- BIC® startet seinen BIC® SHAVE CLUB, seinen **Online Abonnement-Service** für einen nachfüllbaren BIC®-Rasierer für Männer, zunächst in Frankreich und in Großbritannien.
- BIC® geht mit seiner ersten Endverbraucher-Website in Europa für BIC® 4 Colours Limited Edition-Schreibgeräte online!
- Als historischer Partner des berühmten Radrennens wird BIC® wieder auf den Straßen Frankreichs unterwegs sein. Eine einzigartige Gelegenheit, seine Endverbraucher zu treffen.

IT / Marchio

- Vicino a te.
- BIC® è sempre vicino. Annunci classici, Cross-Marketing, visibilità in negozio, visibilità commerciale, innovative campagne digitali e di social media... Il marchio BIC® è sempre presente nella mente dei tuoi clienti.
- **Le campagne e gli eventi** offrono forme nuove e originali di connettersi con i consumatori di BIC.
- BIC® lancia BIC® SHAVE CLUB, il suo servizio di **sottoscrizione on-line** con un rasoio ricaricabile BIC® per uomo, iniziando in Francia e nel Regno Unito.
- BIC® lancia il suo **primo sito web di commercio elettronico diretto al consumatore** in Europa per la penna BIC® 4 Colours Edizione Limitata!
- Partner storico della famosa competizione di ciclismo, BIC sarà, ancora una volta, in viaggio lungo le strade di Francia. Un'opportunità unica di incontrare i propri consumatori.

Brand

Close to you

BIC® is always nearby. Classic Ads, Cross-Marketing, In-Store Visibility, Trade Visibility, Innovative Digital & Social Media Campaigns... BIC® Brand is always present in the mind of your customers.



- Campaigns and events offer new, original ways of connecting with BIC® consumers.



- BIC® launches BIC® SHAVE CLUB, its **online subscription service** with a BIC® refillable shaver for men, starting in France and in the United Kingdom.



- BIC® launches its **first Direct to Consumer e-commerce website** in Europe for BIC® 4 Colours Limited Edition pens!

BIC® OFFICIAL SUPPLIER OF THE 2018 TOUR DE FRANCE



- Historical partner of the famous cycling competition, BIC® will, once again, travel across the roads of France in 2018. **A unique opportunity to meet its consumers.**

FR / Groupe

- Une présence globale. BIC® fabrique dans 24 de ses propres usines réparties dans le monde, pour mieux répondre aux demandes d'expertises produits et mieux servir les marchés locaux.
- 24 usines à travers le monde.
- 15,500 employés dans le monde.
- 89 Nationalités *Données à décembre 2016
- 160 pays.

ES / Grupo

- Una presencia global. BIC® posee y mantiene 24 plantas principales en todo el mundo, desarrolladas según el producto específico expertisen y para servir mejor a los mercados del Grupo a nivel local.
- 24 fábricas alrededor del mundo.
- 15,500 empleados en todo el mundo.
- 89 nacionalidades *Desde diciembre 2016
- 160 países.

DE / Gruppe

- Eine Globale Präsenz. BIC® besitzt und betreibt weltweit 24 Hauptwerke, die basierend auf spezifischer Produkterfahrung aufgebaut wurden und um die lokalen Märkte der Gruppe besser bedienen zu können.
- 24 Fabriken weltweit.
- 15,500 Mitarbeiter weltweit.
- 89 Nationalitäten * Stand Dezember 2016
- 160 Länder.

IT / Gruppo

- Una presenza globale. BIC® possiede e gestisce 24 impianti principali in in tutto il mondo, sviluppati secondo la specifica competenza di prodotto e per servire al meglio i mercati del Gruppo localmente.
- 24 fabbriche in tutto il mondo.
- 15,500 impiegati a livello mondiale.
- 89 Nazionalità *A dicembre 2016
- 160 paesi.



A global presence

BIC® owns and maintains **24 principal plants around the world**, developed according to specific product expertise and to better serve the Group's markets locally.

📍 (14) Stationery 📍 (5) Lighters 📍 (4) Shavers 📍 (1) Promotional

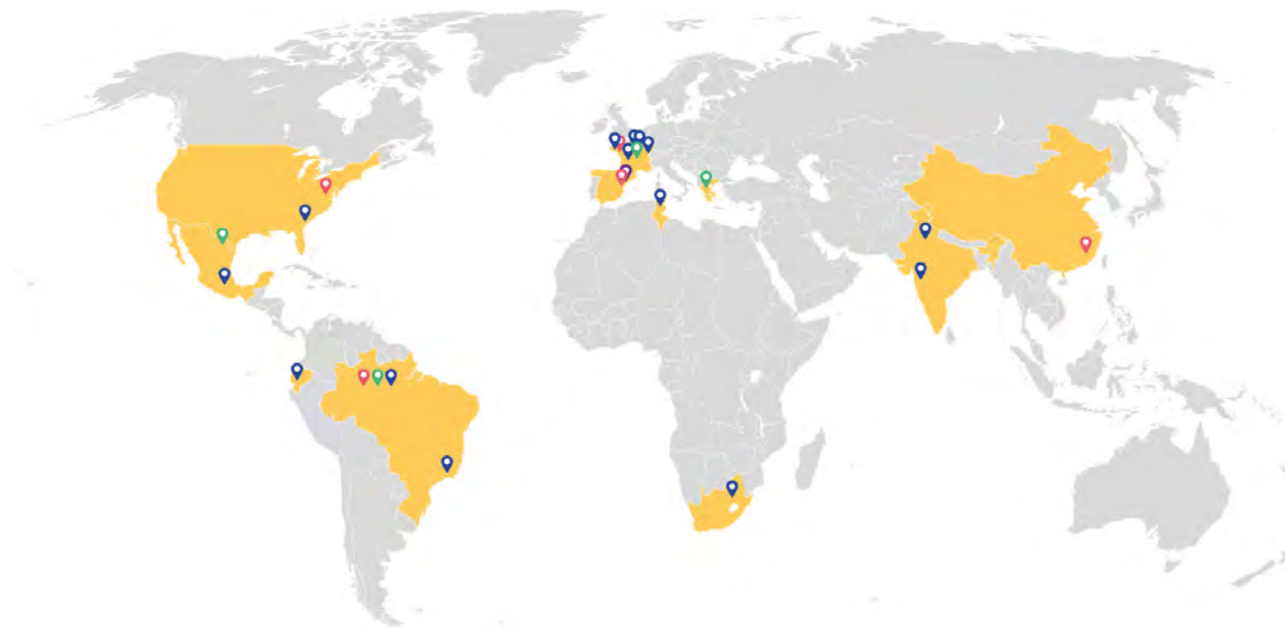

90% of the BIC® Net Sales are produced in BIC® owned factories*

*excluding Cello Pens

FR / Développement durable

- Nous savons faire la différence. Et nous savons que la façon dont nous fabriquons et distribuons nos produits est importante.
- Des produits absorbables fabriqués pour durer. Depuis le début, BIC® a toujours fabriqué ses produits avec le "juste nécessaire", laissant de côté le superflu. Nos priorités : économiser les matières, innover, et saisir les opportunités offertes par l'économie circulaire (destinées à réduire les déchets), tout en continuant à offrir des produits abordables, facilement disponibles et modernes.
- Léger et...durable, économique, Ecologique. Réduction de notre empreinte environnementale.
- BIC aspire constamment à réduire l'empreinte environnementale de ses activités, agissant sur tous les fronts : systèmes de management environnemental, optimisation des consommations d'eau et d'énergie, réduction et recyclage des déchets, réduction des émissions de gaz à effet de serre, et plus encore.
- Usines, Transport, Packaging. 24%: Réduction de la consommation d'énergie par tonne de production dans les 10 dernières années. 85%: Réduction de la consommation d'eau par tonne de production dans les 10 dernières années. 90,3% de nos cartons d'emballages viennent d'origines certifiées et/ou recyclées.
- Unir les personnes autour de valeurs clés. Engagement pour l'éducation
- Pour en savoir plus sur le développement durable chez BIC® : bicworld.com/en/our-commitments/overview

ES / Desarrollo sostenible

- Apostamos por marcar la diferencia. Y sabemos cómo desarrollar nuestros productos y conducir nuestro negocio.
- Productos asequibles hechos para durar. Desde el comienzo, BIC® siempre ha fabricado sus productos con "sólo lo necesario", dejando de lado todo lo superfluo. Nuestras prioridades: ahorrar materiales, innovar y aprovechar las oportunidades que ofrece la economía circular (destinada a reducir los residuos), mientras continuamos ofreciendo productos asequibles, fácilmente disponibles y modernos.
- Ligero y...de larga duración, asequible, ecológico. Reduciendo nuestra huella ambiental. BIC® se esfuerza constantemente en reducir su huella ambiental en sus operaciones, actuando en todos los frentes: sistemas de gestión ambiental, optimización del consumo de agua y energía, reducción y reciclaje de residuos, reducción de emisiones de gases de efecto invernadero, y más.
- Fábricas, Transporte, Embalaje. 24%: Reducción en el consumo de energía por tonelada de producción en los últimos 10 años. 85%: Reducción en el consumo de agua por tonelada de producción en los últimos 10 años. 90,3% de envases de cartón proviene de fuentes certificadas y/o recicladas.
- Uniendo a nuestras personas alrededor de valores clave. Compromiso con la educación.
- Más información sobre Desarrollo Sostenible en: bicworld.com/en/our-commitments/overview

DE / Nachhaltige Entwicklung

- Wir sind überzeugt, dass wir etwas bewegen können. Und wir tun es in der Art, wie wir unsere Produkte herstellen und in unserem unternehmerischen Handeln.
- Produkte, die erschwinglich und langlebig sind. Bereits von Anfang an hat BIC® seine Produkte immer mit „dem Nötigsten“ hergestellt und alles Überflüssige weggelassen.
- Unsere Prioritäten: Material einsparen, Innovationen entwickeln, Chancen in der Kreislaufwirtschaft ergreifen (mit dem Ziel Abfall zu reduzieren), und gleichzeitig erschwingliche, jederzeit verfügbare und moderne Produkte anzubieten.
- Leichtgewicht &... Langlebig, Erschwinglich, Umweltfreundlich. Unseren ökologischen Fußabdruck reduzieren. BIC® strebt kontinuierlich danach, den ökologischen Fußabdruck seines Handelns zu reduzieren und arbeitet dabei in alle Richtungen: Umweltmanagementsystem, Optimierung des Wasser- und Energieverbrauchs, Reduzierung und Recycling von Abfall, Reduktion der Treibhausgasemissionen und weitere.
- Fabriken, Transport, Verpackung. 24 %: Reduzierung des Energieverbrauchs pro Tonne Produktionsmenge in den letzten 10 Jahren. 85 %: Reduzierung des Wasserkonsums pro Tonne Produktionsmenge in den letzten 10 Jahren. 90,3 % der Kartonverpackungen kommen aus zertifizierten und/oder Recycling-Quellen.
- Unsere Mitarbeiter einigen sich auf Grundwerte. Zur Weiterbildung verpflichtet.
- Erfahren Sie mehr über Nachhaltigkeitsentwicklung: bicworld.com/en/our-commitments/overview

IT / Sviluppo sostenibile

- Noi crediamo nel fare la differenza. E sappiamo come realizzare i nostri prodotti e condurre i nostri affari.
- Prodotti economici fatti per durare.
- Fin dal principio, BIC® ha sempre realizzato i suoi prodotti "solo con il necessario", tralasciando tutto il superfluo.
- Le nostre priorità: risparmiare materiale, innovare e cogliere l'opportunità offerta dall'economia circolare (destinata a ridurre i rifiuti), nel mentre continuare ad offrire prodotti economici, prontamente disponibili e moderni.
- Leggero e...di lunga durata, economico, ecologico. Riducendo il nostro impatto ambientale.
- BIC è costantemente impegnata a ridurre l'impatto ambientale delle sue operazioni, agendo su ogni fronte: sistemi di gestione ambientali, ottimizzazione dei consumi di acqua ed energia, riduzione e riciclo dei rifiuti, diminuzione delle emissioni di gas a effetto serra, e oltre.
- Fabbriche, Trasporto, Imballaggio. 24%: Riduzione del consumo di energia per tonnellata di produzione negli ultimi 10 anni. 85%: Riduzione nel consumo di acqua per tonnellata di produzione negli ultimi 10 anni. 90,3% di cartone per imballaggio proviene da fonti certificate e/o riciclate.
- Unendo le nostre persone attorno ai valori chiave. Impegno all'istruzione
- Maggiori informazioni riguardo allo Sviluppo Sostenibile: bicworld.com/en/our-commitments/overview

Sustainable development

We believe in making a difference

And we know that how we make our products and conduct our business matters

AFFORDABLE PRODUCTS MADE TO LAST.

From the beginning, BIC® has always made its products with “just what’s necessary,” leaving out anything superfluous. Our priorities: save materials, innovate, and seize opportunities offered by the circular economy (aimed at reducing waste), while continuing to offer affordable, readily available, and modern products.



LIGHTWEIGHT &...



... LONG LASTING



AFFORDABLE

REDUCING OUR ENVIRONMENTAL FOOTPRINT.

BIC® is constantly striving to reduce the environmental footprint of its operations, acting on every front: environmental management systems, optimisation of water and energy consumption, reduction and recycling of waste, reducing greenhouse gas emissions, and more.



FACTORIES



TRANSPORTATION



PACKAGING



24%

Reduction in energy consumption per ton of production in the past 10 years.



85%

Reduction in water consumption per ton of production in the past 10 years.



90,3%

Of cardboard packaging comes from certified and/or recycled sources.

UNITING OUR PEOPLE AROUND KEY VALUES



COMMITMENT TO EDUCATION



Learn more about Sustainable Development:
[bicworld.com/en/our-commitments/overview](https://www.bicworld.com/en/our-commitments/overview)

FR / Groupe . Développement durable

- 20 MILLIONS DE STYLOS COLLECTES DEPUIS 2011 DANS 7 PAYS
- Seconde vie
Bien qu'ils soient faits pour durer, il arrive un jour où les produits BIC® expirent. C'est à ce moment que notre partenariat BIC®- TerraCycle rentre en jeu : Premier programme européen pour les instruments d'écriture usagés. Collectés dans 7 pays, dans les écoles et les bureaux, stylos bille, feutres, marqueurs, stylos effaçables et les surligneurs vont être recyclés – une fin heureuse pour 20 millions d'instruments d'écriture usagés."
- UBICUITY™:
Après une avancée dans le programme de collecte d'instruments d'écriture lancé en Mars 2011 avec TerraCycle, BIC® démarre un nouveau chapitre pour entrer dans l'économie circulaire. En partenariat avec Plas Eco, une compagnie Française spécialisée en design, fabrication et l'approvisionnement de mobiliers pour l'extérieurs, BIC® a créé la première gamme de mobiliers pour l'extérieur fabriqués en France à partir de stylos recyclés.
- Consultez plus d'informations au sujet de ce projet, ici
- LAUREAT DU PRIX PSI DURABILITE 2017
- EXCELLENCE ECONOMIQUE. Performances remarquables dans le management environnemental et social
- PRODUIT DURABLE. BIC® Evolution® Ecolutions® set de crayons de couleurs, un concept établi durablement
- Une reconnaissance de notre engagement pour le développement durable depuis des décennies
- Scannez pour accéder au rapport développement durable du Groupe BIC®

ES / Grupo . Desarrollo sostenible

- 20 MILLONES DE BOLÍGRAFOS RECOGIDOS DESDE 2011 EN 7 PAÍSES
- Segunda vida
Aunque está hecho para durar, llega un día en que incluso los productos BIC® caducan. Es entonces cuando entra en juego la asociación TerraCycle de BIC®: el primer programa de reciclaje de Europa para instrumentos de escritura usados. Recogidos en siete países, en escuelas y oficinas, se reciclan bolígrafos, rotuladores, marcadores, subrayadores y resaltadores, un final feliz para más de 20 millones de instrumentos de escritura usados."
- UBICUITY™:
Dando un paso adelante en el programa de colección de instrumentos de escritura lanzado en marzo de 2011 con TerraCycle, BIC® está comenzando un nuevo capítulo para ingresar a la economía circular. En asociación con Plas Eco, una empresa francesa especialista en el diseño, fabricación y suministro de muebles para exteriores, BIC® ha creado la primera gama de muebles de exterior fabricados en Francia a partir de bolígrafos reciclados.
- Encuentra más información sobre este proyecto aquí
- GANADOR DEL PREMIO DE SOSTENIBILIDAD PSI 2017
- EXCELENCIA ECONÓMICA. Actuaciones destacadas en gestión ambiental y social
- PRODUCTO SOSTENIBLE. BIC® Evolution® Ecolutions® Colouring Set, un concepto de implementos sostenibles
- Un reconocimiento de nuestras décadas de compromiso con el desarrollo sostenible
- Escanear para ver el informe de sostenibilidad del grupo BIC

DE / Gruppe. Nachhaltigkeitsentwicklung

- 20 MILLIONEN SCHREIBGERÄTE WURDEN SEIT 2011 IN 7 LÄNDERN GESAMMELT
- Zweites Leben
Obwohl sie langlebig hergestellt wurden kommt der Tag, an dem BIC®-Produkte ausgedient haben. Dann kommt die BIC® TerraCycle Partnerschaft ins Spiel: Europas erstes Recyclingprogramm für ausgediente Schreibgeräte. In Schulen und Büros aus sieben Ländern gesammelte Kugelschreiber, Filzstifte, Marker, radierbare Schreiber und Highlighter werden recycelt – ein Happy End für über 20 Millionen verbrauchte Schreibgeräte.
- UBICUITY™:
Nachdem BIC® mit dem Schreibgeräte-Sammelprogramm im März 2011 mit TerraCycle einen Schritt voran gegangen ist, starten wir ein neues Kapitel in der Kreislaufwirtschaft. In Partnerschaft mit Plas Eco, einem französischen Unternehmen, das spezialisiert ist auf Design, Produktion und Lieferung von Outdoor-Möbeln, wurde das erste in Frankreich produzierte Outdoor-Möbelsortiment aus recycelten Schreibgeräten geschaffen.
- Hier finden Sie weitere Informationen über dieses Projekt
- GEWINNER DES 2017 PSI SUSTAINABILITY AWARDS
- ECONOMIC EXCELLENCE. Herausragende Leistungen im Umwelt- und Sozialmanagement
- SUSTAINABLE PRODUCT. BIC® Evolution® Ecolutions® Colouring Set, ein nachhaltig umgesetztes Konzept
- Eine Anerkennung unserer jahrzehntelangen Verpflichtung zur Nachhaltigkeitsentwicklung
- Scannen Sie hier für den Nachhaltigkeitsbericht der BIC GRUPPE

IT / Gruppo . Sviluppo Sostenibile

- 20 MILIONI DI PENNE RACCOLTE FIN DAL 2011 IN 7 PAESI
- Seconda vita
Anche se fatti per durare, arriva un giorno che persino i prodotti BIC® si esauriscono. Quello è il momento in cui l'associazione partner di BIC® TerraCycle entra in gioco: il primo programma in Europa di riciclo degli strumenti di scrittura usati. Raccolti in sette paesi, in scuole ed uffici, penne a sfera, pennarelli, marcatori, penna cancellabili ed evidenziatori sono stati riciclati - una felice fine per oltre 20 milioni di strumenti di scrittura usati."
- UBICUITY™:
Facendo un passo in avanti nel programma di raccolta di strumenti di scrittura lanciato a marzo 2011 con TerraCycle, BIC® sta avviando un capitolo nuovo per entrare nell'economia circolare. In associazione con Plas Eco, una società francese specializzata nel disegno, fabbricazione e fornitura di arredamento da esterno, BIC® ha creato la prima gamma di arredamento da esterno fabbricata in Francia partendo da penne riciclate.
- Trova maggiori informazioni circa questo progetto qui
- VINCITORE DEL PREMIO DI SOSTENIBILITA' PSI 2017
- ECCELLENZA ECONOMICA. Prestazioni notevoli in gestione ambientale e sociale
- PRODOTTI SOSTENIBILI. BIC® Evolution® Ecolutions® Colouring Set, un concetto di sostenibilità applicata
- Un riconoscimento al nostro decalogo di impegno allo sviluppo sostenibile
- Scannerizza per visualizzare il report di sostenibilità del gruppo BIC

Sustainable development



20
MILLION PENS
COLLECTED SINCE 2011
IN 7 COUNTRIES

SECOND LIFE

Although made to last, there comes a day when even BIC® products expire. That's when BIC®'s TerraCycle partnership comes into play: Europe's first recycling program for used writing instruments. Collected in seven countries, in schools and offices, ball pens, felt pens, markers, erasable pens and highlighters are being recycled – a happy end for more than 20 million used-up writing instruments.



The "write" kind of bench™



Find more information about this project here

UBICITY™: THE "WRITE" KIND OF BENCH™

Taking a step forward in the writing instruments collection programme launched in March 2011 with TerraCycle, BIC® is starting a new chapter to enter the circular economy. In partnership with Plas Eco, a French company which specialises in the design, manufacture and supply of outdoor furniture, BIC® has created the first range of outdoor furniture made in France from recycled pens.



WINNER OF THE
2017

PSI SUSTAINABILITY AWARDS



ECONOMIC EXCELLENCE
Outstanding performances in environmental and social management



SUSTAINABLE PRODUCT
BIC® Evolution® Ecolutions® Colouring Set, a sustainably implemented concept

A RECOGNITION OF OUR DECADES OF COMMITMENT TO SUSTAINABLE DEVELOPMENT



Scan for BIC GROUP Sustainability report

FR / La sécurité des produits

- C'est testé, et retesté, et retesté... 100 % des billes des stylos sont contrôlées : parfaitement sphériques, elles sont presque aussi dures que le diamant.
- 100 % : tous les briquets de poche BIC® respectent ou dépassent les exigences des normes ou règlements internationaux (ISO 9994, EN13869, ASTM F400, US CPSC).
- 100 % des lames de rasoirs sont inspectées visuellement : analyse statistique des dimensions, mesure de l'angle d'aiguisage, vérification de la parfaite régularité du tranchant,...
- 25 % : Un quart de la journée de chaque opérateur des usines de briquets BIC® est dédié à des contrôles sur la qualité.
- 30 contrôles différents pour produire un rasoir 3, 4 ou 5 lames conforme aux plus strictes exigences de qualité de BIC.
- 50 : Avant de quitter l'usine, chaque briquet BIC® subit plus de 50 contrôles automatiques de qualité et de sécurité.
- 5 usines Briquets avec les mêmes processus de fabrication et contrôles qualité rigoureux.
- Car BIC® fabrique millions de produits, chaque jour. Et où qu'ils soient faits dans le monde, leur qualité est la même : elle a été contrôlée et recontrôlée par des procédures, le plus souvent automatiques, des tests visuels, techniques et mécaniques. Il y a des vérifications en laboratoire et des essais en condition réelle.

ES / La seguridad de los productos

- Los examinamos una vez, y otra, y otra... El 100% de las bolas de los bolígrafos están controladas. Son perfectamente esféricas y casi más duras que un diamante.
- 100%: Todos los encendedores de bolsillo BIC® cumplen o exceden estándares internacionales y requisitos reglamentarios (ISO 9994, EN 13869, ASTM F400, US CPSC).
- El 100% de las hojas de las maquinillas de afeitar se examinan visualmente: análisis estadístico de las dimensiones, medición del ángulo de afilado, verificación de la perfecta uniformidad del borde de la hoja, etc.
- 25%: Una cuarta parte de jornada de trabajo de un operador en una fábrica de encendedores BIC® está dedicada a controles de calidad.
- 30 controles distintos para producir una maquinilla de 3, 4 ó 5 hojas que cumpla con los estrictos estándares de calidad de BIC
- 50: Antes de salir de la fábrica, cada encendedor BIC® se somete a más de 50 controles de seguridad y calidad automáticos
- 5 fábricas de encendedores con los mismos procesos de fabricación y controles rigurosos de calidad.
- BIC® fabrica millones de productos. Cada día. Donde quiera que se fabriquen, su calidad es constante; se examinan y se reexaminan mediante controles visuales, técnicos y mecánicos, a menudo automáticos. Se realizan pruebas internas y ensayos en condiciones reales.

DE / Produktsicherheit.

- Sie werden getestet, wiederholt getestet, erneut wiederholt getestet...100 % aller Kugelschreiber werden geprüft. Exakt kugelförmig, sind sie fast härter als Diamanten.
- 100 % aller BIC® Taschenfeuerzeuge erfüllen oder übertreffen internationale Standards und die Rechtsvorschriften (ISO 9994, EN 13869, ASTM F400, US CPSC).
- 100 % aller Rasierklingen werden visuell geprüft: statische Maßkontrollen, Schleifwinkel-Messungen, perfekte Glattheit der Klingenkanten-Prüfung, etc.
- 25%: Ein Mitarbeiter einer BIC®-Feuerzeugfabrik verbringt ein Viertel seines Arbeitstages mit Qualitätschecks.
- 30 verschiedene Kontrollen durchläuft ein Rasierer mit 3-, 4- oder 5-Klingen, um die strengen BIC®-Qualitätsstandards zu erfüllen.
- 50: Vor dem Verlassen der Fabrik durchläuft jedes BIC®-Feuerzeug über 50 automatische Qualitäts- und Sicherheitschecks.
- 5 Feuerzeug-Fabriken mit exakt identischen strengen Produktionsprozessen und Qualitätschecks.
- BIC® produziert Millionen Produkte. Täglich. Überall, wo sie auf der ganzen Welt hergestellt werden, ist ihre Qualität gleichbleibend hoch. Sie wird geprüft und wiederholt geprüft durch visuelle, technische, mechanische, oftmals automatische Kontrollen. Neben den Inhouse-Tests werden Tests unter realen Bedingungen durchgeführt.

IT / La sicurezza dei prodotti

- Vengono testati una, due, tre volte...Il 100% delle sfere delle penne è sottoposto a controlli. Perfettamente sferiche, sono quasi più dure di un diamante.
- Il 100% degli accendini tascabili BIC® soddisfa o supera gli standard internazionali e i requisiti normativi (ISO 9994, EN 13869, ASTM F400, US CPSC).
- Il 100% delle lamette per rasoi è ispezionato visivamente: controlli statistici dimensionali, misurazione dell'angolo di affilatura, analisi della perfetta scorrevolezza del bordo della lama, ecc.
- Il 25%, un quarto della giornata di un operatore di uno stabilimento di accendini BIC®, è dedicato ai controlli di qualità.
- 30 diversi controlli per produrre un rasoio a 3, 4 o 5 lame che sia conforme ai rigorosi standard di qualità di BIC.
- 50: Prima di lasciare lo stabilimento, ogni accendino BIC® è sottoposto a più di 50 controlli automatici di qualità e sicurezza.
- 5 impianti per la produzione di accendini con gli stessi rigorosi processi di produzione e controlli di qualità.
- BIC® realizza milioni di prodotti. Ogni giorno. Indipendentemente da dove vengano prodotti, la qualità è costante ed è verificata in più fasi tramite controlli visivi, tecnici, meccanici e spesso automatici. I collaudi si svolgono a livello interno e sul campo.

Product safety

They're tested, re-tested, re-re-tested...



- 100% of ballpoints are controlled. Perfectly spherical, they are almost harder than a diamond



- 100%: All BIC® pocket lighters meet or exceed international standards and regulation requirements (ISO 9994, EN13869, ASTM F400, US CPSC)



- 100% of all shaver blades are visually inspected: dimensional static checks, sharpening angle measurement, perfect smoothness of the blade-edge assessment, etc



- 25%: One quarter of an operator's workday in a BIC® lighter factory is dedicated to quality checks



- 30 different controls to make a 3, 4 or 5-blade shaver that conforms to BIC®'s stringent quality standards



- 50: Before leaving the factory, every BIC® lighter undergoes more than 50 automatic quality and security checks



- 5 lighter plants with the exact same rigorous production processes and quality checks

BIC® manufactures millions of products. Daily.

Wherever they are made in the world, BIC® product quality is constant; checked and rechecked by visual, technical, mechanical, often automatic controls. In-house testing and real-life testing.

Printing Techniques

With more than



of experience
as guarantee!

Make your brand stand out
with our printing techniques
and finishes

**FR / Techniques
d'impression**

- La garantie inhérente à plus de 50 années d'expérience ! Faites ressortir votre marque grâce à nos techniques d'impression et finitions.

**ES / Técnicas
de impresión**

- ¡Más de 50 años de experiencia nos avalan! Haz que tu marca destaque con nuestros acabados y técnicas de impresión.

DE / Drucktechniken

- Über 50 Jahre garantierte Erfahrung! Stellen Sie Ihre Marke mit unseren Drucktechniken und -oberflächen in den Vordergrund.

**IT / Tecniche
di stampa**

- Con oltre 50 anni di esperienza come garanzia! Metti in luce il tuo marchio grazie alle nostre tecniche di stampa e finiture.

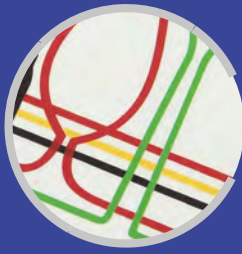

SCREEN PRINTING



PAD PRINTING



DIGITAL PRINTING



DIGITAL LABEL



LASER ENGRAVING



BRITEPIX™



DOMING



STAMPING



BRITEPIX™ TEXTURE



DEBOSSING



SCREEN TRANSFER

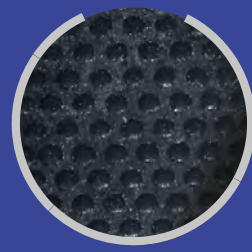

3D PUFFY PRINTING



SUBLIMATION



METALLIC INK

FR / Outils numériques :

- Le catalogue BIC Graphic toujours avec vous
La version numérique du catalogue général 2018
Information mise à jour continuellement! Disponibilité des produits, calculateur de prix, stock, recherche avancée, marque pages, promotions en cours et bien plus encore...
- Vivez une expérience incroyable de Réalité Augmentée avec des effets surprenants.
- Jouez avec le configurateur produit 3D pour sélectionner votre choix de combinaisons de couleurs
- Téléchargez votre logo
- Regardez les vidéos des produits BIC® les plus iconiques
- Customisez vos images avec le service de personnalisation
- Scannez cette icône sur les pages produits et vous verrez les produits prendre vie!
- Saisissez vos commandes RAPIDEMENT et FACILEMENT!
- Complétez l'information produit : détails produits et images, disponibilité du stock, prix, possibilités d'impression, packaging et les outils multimedia.
- Configurateur produit: configurateur 2D et 3D pour tous les produits. Téléchargez votre logo et obtenez une maquette virtuelle.
- Prix tout inclus : facile, un prix avec tout inclus: set up charges, impression et coût de transport.
- E-cotation: les conditions tarifaires avec toutes les informations requises avec votre logo en un seul click !
- Commande en ligne : processus de commande complet, une vue des commandes en cours ou passées, les attentes d'accord sur les fiches de marquage et les factures, etc.
- Assistance en ligne : tchat en ligne.
- Besoin d'un site internet ?:
- Construction facile de votre propre site internet basé sur notre propre modèle, gratuitement !

ES / Herramientas digitales

- Catálogo BIC Graphic en marcha
La versión digital del catálogo genérico 2018
¡Un lugar donde la información está siempre actualizada!
Disponibilidad del producto, calculadora de precios, inventario, búsqueda avanzada, marcadores, promociones en curso y mucho más...
- Vive una experiencia increíble de Realidad Aumentada con efectos sorprendentes.
- Juega con el configurador de productos 3D y selecciona la combinación de colores.
- Carga tu logo
- Mira los videos de los productos más emblemáticos de BIC®
- Modifica tus imágenes con el servicio de personalización
- ¡Al escanear una de las páginas del catálogo que presenta el siguiente icono, podrás ver que el producto se convierte en realidad!"
- ¡Haz tus pedidos MÁS RÁPIDO Y MÁS FÁCIL!
- Información completa del producto: detalles e imágenes del producto, disponibilidad de stock, precio, posibilidades de impresión, embalaje y herramientas multimedia.
- Configurador de productos: configurador 2D y 3D para todos los artículos. Sube tu logo y obtén una muestra virtual gratuita. Precio todo incluido: fácil, un precio que lo incluye todo: gastos de instalación, impresión y transporte.
- E-quotation: ¡toda la información requerida con tu propio logo y tus condiciones de precios con un solo clic!
- Pedidos en línea: proceso completo de pedidos, resumen de pedidos actuales y pasados, aprobaciones y facturas pendientes de artes finales, etc.
- Asistencia online: chat en vivo.
- ¿Necesitas un sitio web?: ¡Crea fácilmente tu propio sitio web basado en nuestro propio modelo, gratis!

DE / Digitale Tools

- BIC Graphic Katalog für unterwegs
Die digitale Version des 2018 Gesamtkataloges
Konstant aktualisierte Informationen! Produktverfügbarkeit, Preiskalkulator, Lagerbestand, erweiterte Suche, Lesezeichen, laufende Promotions und vieles mehr...
- Erleben Sie eine unglaubliche Erfahrung der „erweiterten Realität“ mit überraschenden Effekten.
- Spielen Sie mit dem 3D-Produktkonfigurator um Ihre gewünschte Farbkombination auszuwählen
- Laden Sie Ihr Logo hoch
- Sehen Sie sich die Produktvideos der kultigsten BIC®-Produkte an
- Passen Sie Ihre Fotos mit dem Personalisierungsservice an
- Scannen Sie dieses Icon auf den Produktseiten und erleben Sie, wie das Produkt zum Leben erweckt wird!
- Platzieren Sie Ihre Bestellungen SCHNELLER und EINFACHER!
- Vollständige Produktinformation: Produktdetails und -fotos, Lagerverfügbarkeit, Preis, Druckmöglichkeiten, Verpackung und Multimedia Tools.
- Produktkonfigurator: 2D- und 3D- Konfigurator für alle Artikel. Laden Sie Ihr Logo hoch und erhalten Sie ein kostenloses virtuelles Muster.
- All-inklusive-Preis: einfach, ein Preis inklusive aller Extras: Einrichtungskosten, Druck- und Transportkosten.
- E-Angebot: alle benötigten Informationen inklusive Ihres eigenen Logos und Preiskonditionen mit nur einem Klick!
- Online-Bestellungen: vollständige Bestellabwicklung, Überblick über aktuelle und frühere Bestellungen, anstehende Druckvorlagen, Freigaben und Rechnungen etc.
- Online-Assistenz: Live-Chat.
- Sie benötigen eine Website?: Erstellen Sie sich Ihre eigene Website, basierend auf unserem kostenlosen Modell!

IT / Strumenti digitali

- Catalogo BIC Graphic in movimento
Versione digitale del catalogo generale 2018
Informazioni costantemente aggiornate! Disponibilità prodotti, calcolatore prezzi, stock, ricerca avanzata, segnalibri, promozioni in corso e molto di più..
- Vivi un'esperienza incredibile di Realtà Aumentata con effetti sorprendenti.
- Gioca con il configuratore di prodotti 3D e seleziona la tua combinazione di colori.
- Carica il tuo logo. • Guarda il video dei prodotti più iconici di BIC
- Modifica la tua immagine con il servizio di personalizzazione
- Scannerizza questa icona nelle pagine dei prodotti e vedrai il prodotto prendere vita!
- Fai i tuoi ordini PIU' VELOCEMENTE e PIU' FACILMENTE!
- Informazione completa del prodotto: dettagli e immagini del prodotto, disponibilità, prezzo, possibilità di stampa, imballo e strumenti multimedia.
- Configuratore prodotto: configuratore 2D e 3D per tutti gli articoli. Carica il tuo logo e ottieni un campione virtuale.
- Prezzo all inclusive: facile, un prezzo con tutto incluso: impianto, stampa e trasporto.
- E-quotation: tutte le informazioni con il tuo logo e le tue condizioni di prezzo con un solo clic!
- Ordini online: processo completo dell'ordine, visualizzazione degli ordini in corso e passati, approvazione delle bozze in attesa e fatture, etc.
- Assistenza online: live chat.
- Necessiti di un sito?:
- Crea facilmente il tuo sito sulla base del nostro gratuitamente!

Digital tools



BIC Graphic catalogue on the go

The digital version of the 2018 general catalogue

- Information constantly updated!
- Product availability, price calculator, stock, advanced searching,
- bookmarks, ongoing promotions and much more...



BIC Graphic App



- **LIVE** an incredible experience of **Augmented Reality** with surprising effects.
- **PLAY** around with the **3D product configurator** to select your decided colour combination
- **UPLOAD** your logo
- **WATCH** the product videos of the **most iconic BIC®** products
- **CUSTOMISE** your pictures with **personalization service**



Scan this icon on the product pages and, you'll see that the product comes to life!



Our online shop: www.bicgraphic.eu

Place your orders **FASTER** and **EASIER!**

- **Complete product information:** product details and images, stock availability, price, printing possibilities, packaging and multimedia tools
- **Product configurator:** 2D and 3D configurator for all items. Upload your logo and get a free visual.
- **All inclusive price:** easy, one price with everything included: set up charges, printing & transport costs
- **E-quotation:** all the information required with your own logo and pricing conditions with just one click!
- **Online orders:** complete order processing, overview of current and past orders, pending artworks approvals and invoices, etc.
- **Online assistance:** live chat
- **Need a website?:** Easily build your own website based on our own model for free!



FR / Marques partenaires



- T'nB® - notre partenaire exclusif et marque technologique innovante depuis plus de 30 ans, qui respecte les règles strictes concernant les produits technologiques en apportant un design Français unique et une qualité excellente à vos clients.

Sprouta

- Faites la connaissance de Sprout™, le crayon qui rend vert d'envie les stylos en plastiques! Utilisez votre crayon, et ensuite plantez-le et regardez le pousser!



- SKROSS® - reconnue mondialement comme sûr, simple et Suisse : Profitez d'un moment inoubliable avec le # 1 en énergie pour le voyage!

ES / Partner brands



- T'nB®, nuestra exclusiva partner brand tecnológica innovadora durante más de 30 años, cumple con las estrictas regulaciones de productos tecnológicos que brindan a sus clientes un diseño francés único y una calidad excelente.

Sprouta

- ¡Conoce Sprout™, el lápiz que hará que cualquier bolígrafo de plástico sea verde! Usa tu lápiz, después plántalo y mira cómo crece.



- SKROSS® - son globalmente reconocidos como seguros, simples y suizos: ¡Disfruta de un viaje inolvidable con el número uno en energía para viajar!

DE / Partnermarken



- T'nB® - unsere exklusive Technologie-Partnermarke, innovativ seit über 30 Jahren, erfüllt die strengen Bestimmungen für technologische Produkte und bietet Ihren Kunden einzigartiges französisches Design und hervorragende Qualität.

Sprouta

- Treffen Sie Sprout™, den Bleistift, der Plastikschreibgeräte grün werden lässt vor Neid! Verwenden Sie Ihren Bleistift, pflanzen Sie ihn danach ein und genießen Sie, was daraus wächst.



- SKROSS® - weltweit renommiert als sicher, einfach und Schweizerisch: Genießen Sie eine unvergessliche Reise mit der Nr. 1 in Travel Power!

IT / Marchi partner



- T'nB® - il nostro esclusivo marchio partner in tecnologia innovativo da oltre 30 anni, assolve alle severe regolamentazioni sui prodotti tecnologici e offre ai tuoi clienti un design francese unico e una qualità eccellente!

Sprouta

- Scopri Sprout™, la matita che rende le penne in plastica verdi di invidia! Usa la tua matita, poi piantala e guardala crescere.



- SKROSS® - globalmente riconosciuto come sicuro, semplice e svizzero: Goditi un viaggio indimenticabile con il numero 1 in energia per viaggiare!

Partner brands



T'nB® - our exclusive technology partner brand innovating for more than 30 years, meets the strict regulations of technological products bringing a unique French design and quality excellence to your clients.





Meet Sprout™, the pencil that makes plastic pens green of envy! Use your pencil, then plant it and watch it grow.



SKROSS® - globally renowned as safe, simple and Swiss: Enjoy an unforgettable journey with # 1 in travel power!



BALLPENS

- 88 BIC® 4 Colours
-  97 BIC® 4 Colours 3+1[®]
- 94 BIC® 4 Colours *britePix*[™]
- 90 BIC® 4 Colours Fashion
- 94 BIC® 4 Colours Fashion *britePix*[™]
- 93 BIC® 4 Colours Fine
- 95 BIC® 4 Colours Fluo
- 89 BIC® 4 Colours Mini
- 92 BIC® 4 Colours Shine
- 96 BIC® 4 Colours Stylus
-  91 BIC® 4 Colours Sun
- 83 BIC® Atlantis[®]
- 83 BIC® Atlantis[®] Clear
- 85 BIC® Clic Ecolutions[®]
- 85 BIC® Clic Gold Ecolutions[®]
- 52 BIC® Clic Stic
- 56 BIC® Clic Stic Digital
- 57 BIC® Clic Stic Digital Ecolutions[®]
- 54 BIC® Clic Stic Ecolutions[®]
- 56 BIC® Clic Stic Mini Digital
- 55 BIC® Clic Stic Softfeel[®]
- 58 BIC® Clic Stic Stylus
- 59 BIC® Clic Stic Stylus Digital
- 30 BIC® M10[®] Clic
-  43 BIC® Media Clic Digital
- 48 BIC® Media Clic Grip Digital Ecolutions[®]
- 46 BIC® Media Clic Grip Ecolutions[®]
- 49 BIC® Media Clic Premium
- 34 BIC® Round Stic[®]
- 37 BIC® Round Stic[®] Digital
- 37 BIC® Round Stic[®] Digital Ecolutions[®]
- 36 BIC® Round Stic[®] Ecolutions[®]
- 27 BIC® Style
- 27 BIC® Style Clear
- 62 BIC® Super Clip
- 68 BIC® Super Clip Advance
- 69 BIC® Super Clip Advance *britePix*[™]
- 71 BIC® Super Clip Advance *britePix*[™] Digital

- 70 BIC® Super Clip Advance Digital
- 64 BIC® Super Clip *britePix*[™]
- 67 BIC® Super Clip *britePix*[™] Digital Ecolutions[®]
- 65 BIC® Super Clip *britePix*[™] Ecolutions[®]
- 66 BIC® Super Clip *britePix*[™] Digital
- 66 BIC® Super Clip Digital
- 67 BIC® Super Clip Digital Ecolutions[®]
- 65 BIC® Super Clip Ecolutions[®]
- 74 BIC® Wide Body[™]
- 78 BIC® Wide Body[™] Chrome
- 76 BIC® Wide Body[™] Digital
- 79 BIC® Wide Body[™] Chrome Digital
- 77 BIC® Wide Body[™] Digital Ecolutions[®]
- 75 BIC® Wide Body[™] Ecolutions[®]
- 80 BIC® Wide Body[™] Mini Digital
- 81 BIC® Wide Body[™] Mini Digital Chrome

METALLIC PENS

- 103 BIC® Attriant[®]
- 100 BIC® Citation
- 106 BIC® Protusion Grip
- 102 BIC® Rondo Evo
- 102 BIC® Rondo Evo Soft
- 101 BIC® Slim Metal
- 107 BIC® Tri-Tone Twist
- 105 BIC® Wide Body[™] Metal
- 104 BIC® Wide Body[™] Metal Grip

ROLLERS & GELS

- 109 BIC® Atlantis[®] Gel
- 113 BIC® Grip Roller
- 113 BIC® Grip Roller Gold
- 111 BIC® Intensity[®] Gel Clic
- 110 BIC® Triumph 537R
- 115 BIC® XS Finestyle
- 115 BIC® XS Finestyle *britePix*[™]

HIGHLIGHTERS & MARKERS

- 122 BIC® Brite Liner[®] Grip
- 123 BIC® Brite Liner[®] Grip XL
- 119 BIC® Great Eraser White Board Marker

- 120 BIC® Mark-it Permanent Marker
- 121 BIC® Permanent Marker Ecolutions[®]
- 118 BIC® Velleda[®] White Board Marker Fine

PENCILS

- 131 BIC® Evolution[®] Digital Ecolutions[®]
- 130 BIC® Evolution[®] Ecolutions[®]
- 131 BIC® Evolution[®] Metallic Digital Ecolutions[®]
- 126 BIC® Matic[®]
- 127 BIC® Matic[®] Ecolutions[®]
- 129 BIC® Matic[®] Grip
- 128 BIC® Matic[®] Quartz
- 40 BIC® Media Clic
- 43 BIC® Media Clic Digital
- 42 BIC® Media Clic Ecolutions[®]
- 45 BIC® Media Clic Grip
- 47 BIC® Media Clic Grip Digital

COLOURING PENS

- 138 BIC® Evolution[®] Ecolutions[®] Colouring set
- 135 BIC® Evolution[®] Ecolutions[®] set of 6 colouring pencils
- 138 BIC® Plastidecor[®] Colouring Set
- 133 BIC® Plastidecor[®] set of 6 crayons
- 138 BIC® Visa[®] Colouring Set
- 134 BIC® Visa[®] set of 6 felt pens
- 139 Conté[®] by BIC® Colouring Set
- 137 Conté[®] set of 6 colouring pencils

CORRECTION

- 141 Tipp-Ex[®] Mini Pocket Mouse *britePix*[™]

OTHER WRITING INSTRUMENTS

- 143 Basic pen
- 148 Chrome Curved pen
- 144 Click pen
- 146 Curved Grip pen
- 145 Curved pen
- 147 Sleek Stylus Executive pen
- 150 Sleek Stylus Matt pen
- 149 Sleek Stylus pen
- 147 Striped Grip pen
- 147 White Striped Grip pen



WRITING INSTRUMENTS

 **Style & Style Clear**

BIC® WRITING INSTRUMENTS

BALLPENS





Style & Style Clear

EN > Worldwide recognised BIC® cap shape. **Excellent value for money.**

FR > Capuchon BIC® reconnu dans le monde entier. **Excellent rapport qualité-prix.**

ES > Tapón BIC® reconocido mundialmente. **Excelente relación calidad precio.**

DE > BIC®-Kappe mit weltweitem Wiedererkennungswert. **Ausgezeichnetes Preis-Leistungs-Verhältnis.**

IT > Il cappuccio BIC® noto in tutto il mondo. **Eccellente rapporto qualità-prezzo.**



BALLPENS

BIC® WRITING INSTRUMENTS

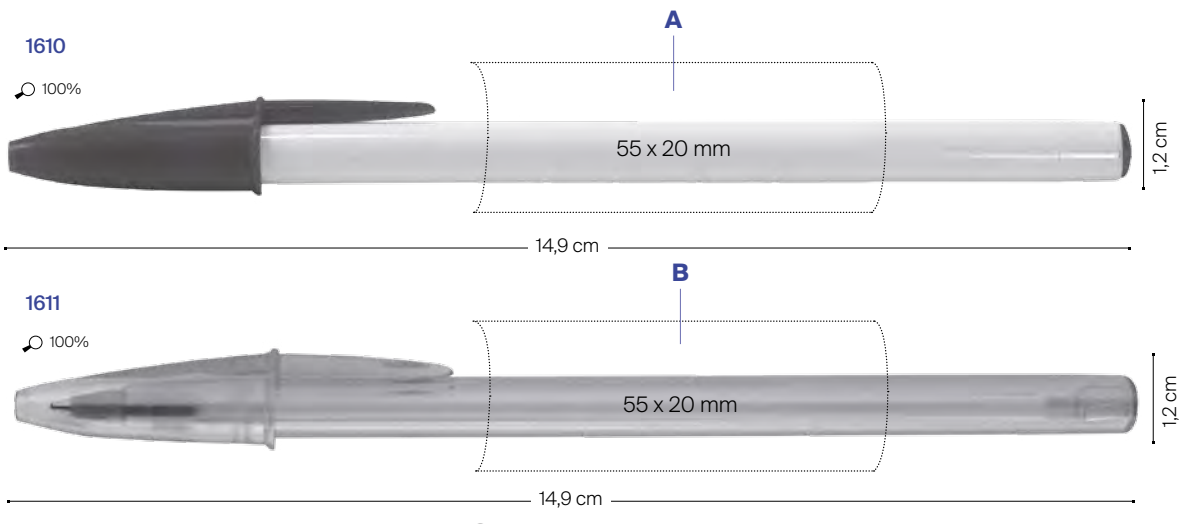

1610/1611 Style Clear
 Ballpen
 Bille
 Bolígrafo
 Kugelschreiber
 Penna a sfera

A > SP: max. 2 colours
B > SP: max. 1 colour

1610
 Barrel and Cap
 OPAQUE



1611
 Barrel and Cap
 CLEAR



MOQ: 500 u.







M10® Clic

The historic retractable ballpen BIC® M10® Clic is back to boost your brand communication at a competitive price.



M10® Clic

EN > The historic retractable ballpen **BIC® M10® Clic** is back to boost your brand communication at a competitive price.

FR > Le grand classique qu'est le stylo à bille rétractable **BIC® M10® Clic** est de retour pour booster la communication de votre marque à un prix compétitif.

ES > El histórico bolígrafo retráctil **BIC® M10® Clic** ha vuelto para impulsar la comunicación de tu marca ¡a un precio competitivo!

DE > Der historische Druckkugelschreiber **BIC® M10® Clic** ist zurück, um Ihre Markenkommunikation zu attraktivem Preis anzukurbeln.

IT > La storica penna a sfera a scatto **BIC® M10® Clic** ritorna per migliorare la comunicazione del tuo marchio a un prezzo competitivo.



01



02



04

Barrel / Ink
OPAQUE



BALLPENS



Iconic BIC® Boy is embossed

100%

1590
Ballpen
Bille
Bolígrafo
Kugelschreiber
Penna a sfera

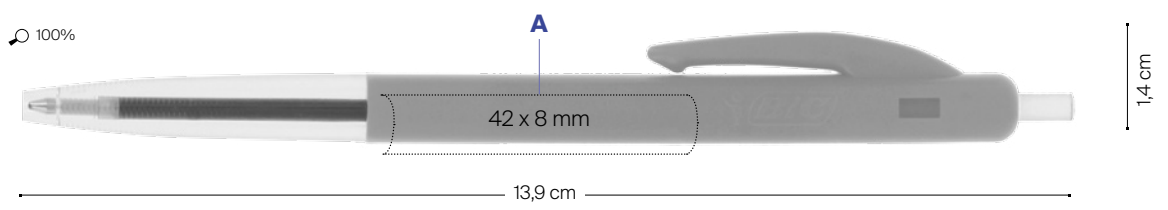

A> SP: max. 2 colours

MOQ: 500 u.







Round Stic®

The iconic BIC® Round Stic® offers timeless style and high quality. Its classic design is easy to identify and symbolises long-term reliability.



Round Stic®

EN > The iconic BIC® Round Stic® offers **timeless style and high quality**. Its classic design is **easy to identify** and symbolises long-term reliability.

FR > L'icône BIC® Round Stic® offre un **style indémodable** et une **très grande qualité**. Son design classique est **facile à identifier** et symbolise une fiabilité à long terme.

ES > El icónico BIC® Round Stic® ofrece un **estilo atemporal y de calidad**. Su diseño clásico se **identifica fácilmente** y simboliza la fiabilidad a largo plazo.

DE > Unser kultiger BIC® Round Stic® bietet **zeitloses Design in bester Qualität**. Sein klassisches Design ist **einfach zu erkennen** und spiegelt lang anhaltende Zuverlässigkeit wieder.

IT > L'iconica BIC® Round Stic® offre uno stile **intramontabile ed alta qualità**. Il suo design classico la rende **facilmente riconoscibile** ed è prova di una longeva affidabilità.



01 02 03 05 07 12 18

100%

1010

Ballpen
Bille
Bolígrafo
Kugelschreiber
Penna a sfera

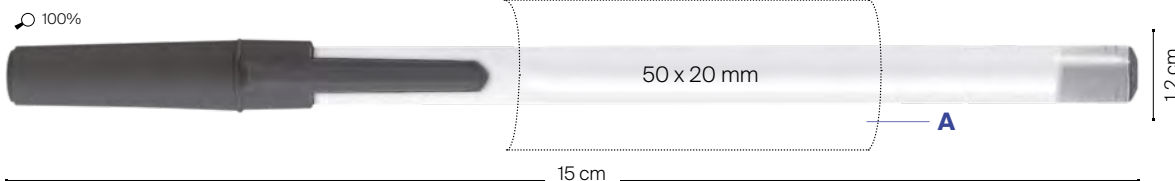

A >
SP: max. 3 colours
B >
SP: max. 1 colour

Cap, Section and Plug
OPAQUE

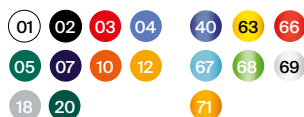

Barrel
OPAQUE





BALLPENS

 Iconic BIC® Boy is embossed

100%

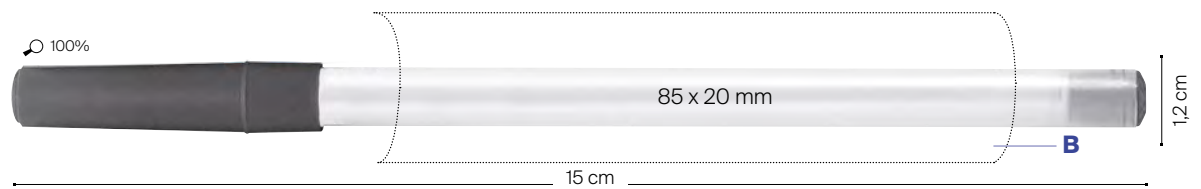

MOQ: 500 u.
 PMS SERVICE
 ≥10.000 u.

    ±2,5 Kg

Red ink available under request



Round Stic®

ecolutions®

- EN >** The iconic BIC® Round Stic® ballpen offers **timeless style** and **high quality**. Its classic design is **easy to identify** and symbolises long-term reliability.
- FR >** L'icône BIC® Round Stic® offre un **style indémodable** et une **très grande qualité**. Son design classique est **facile à identifier** et symbolise une fiabilité à long terme.
- ES >** El icónico BIC® Round Stic® ofrece un **estilo atemporal y de calidad**. Su diseño clásico se **identifica fácilmente** y simboliza la fiabilidad a largo plazo.
- DE >** Unser kultiger BIC® Round Stic® bietet **zeitloses Design in bester Qualität**. Sein klassisches Design ist **einfach zu erkennen** und spiegelt lang anhaltende Zuverlässigkeit wieder.
- IT >** L'iconica BIC® Round Stic offre uno stile **intramontabile ed alta qualità**. Il suo design classico la rende **facilmente riconoscibile** ed è prova di una longeva affidabilità.

* **Made with 69% recycled material.**

The percentage is calculated based on the total weight of the product.



Add the Möbius loop to your artwork at no additional charge. Please be sure to specify "Print the Möbius loop" on your order. (Möbius loop imprint defaults to left-hand hand corner.)



*1E10

Ballpen
Bille
Bolígrafo
Kugelschreiber
Penna a sfera

A>
SP: max. 3 colours
B>
SP: max. 1 colour

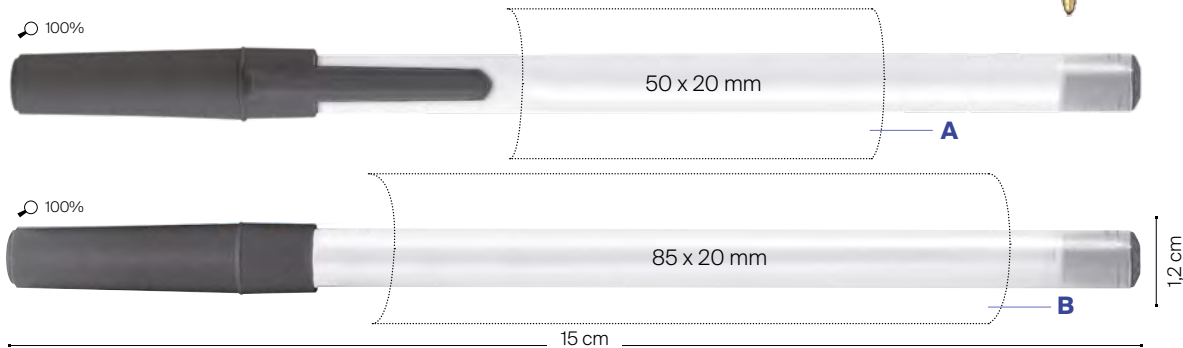

Cap, Section and Button
OPAQUE



Barrel
OPAQUE FROSTED



MOQ: 500 u.

PMS SERVICE
≥10.000 u.



Red ink available under request

If you want more information about our BIC® Ecolutions & how it's made visit: bicgraphic.eu/ie/sustainable-development.html.



MIX & MATCH

Round Stic® Digital & Digital

ecolutions®

By the PIONEER...
In digital printing

- EN >** Hundreds of colour combinations and large **360° full-colour printing area at very competitive price.**
- FR >** Des centaines de combinaisons de couleurs et une large **zone d'impression à 360° dans toutes les couleurs, à un prix très compétitif.**
- ES >** Cientos de combinaciones de colores y una amplia **área de impresión 360° a todo color, a un precio muy competitivo.**
- DE >** Hunderte möglicher Farbkombinationen und ein **großer 360° Vollfarb-Druckbereich zu einem sehr wettbewerbsfähigen Preis.**
- IT >** Centinaia di combinazioni di colori e un'ampia **area stampata a 360°, a colori, ad un prezzo molto competitivo.**



* **Made with 69% recycled material.**

The percentage is calculated based on the total weight of the product.

Add the Möbius loop to your artwork at no additional charge. Please be sure to specify "Print the Möbius loop" on your order. (Möbius loop imprint defaults to left-hand hand corner.)



1881 / *1E11
Ballpen
Bille
Bolígrafo
Kugelschreiber
Penna a sfera

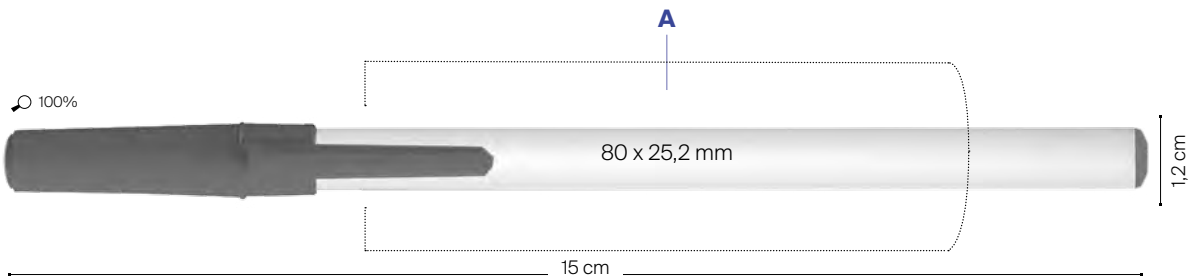

A>
DG: full-colour

1881

Cap, Section and Plug
OPAQUE



FROSTED

Barrel
OPAQUE



1E11

ecolutions®

Cap, Section and Button
OPAQUE



Barrel
OPAQUE



MOQ: 500 u.

PMS SERVICE
≥10.000 u.

500
± 2,5 Kg

MADE IN SPAIN



If you want more information about our BIC® Ecolutions & how it's made
visit: bicgraphic.eu/ie/sustainable-development.html.

Red ink available under request

www.bicgraphic.eu

BALLPENS

BIC® WRITING INSTRUMENTS





Media Clic

The promotional writing instrument of excellence, our number one, the original. Multiple printing possibilities on the barrel and on the clip in up to 4 colours, and thousands of colour combinations for maximum personalisation!



Media Clic

EN > The promotional writing instrument of excellence, our number one, **the original**. Multiple **printing possibilities** on the barrel and on the clip in **up to 4 colours**, and **thousands of colour combinations** for maximum personalisation!

FR > L'outil d'écriture publicitaire par excellence, notre numéro un, **l'original**. De nombreuses **possibilités d'imprimer jusqu'à 4 couleurs** sur le corps et sur le clip, et des milliers de combinaisons de teintes pour une personnalisation maximale !

ES > El instrumento de escritura promocional por excelencia, nuestro número uno, **el original**. ¡Múltiples **posibilidades de impresión en el cuerpo y en el clip hasta 4 colores**, y miles de combinaciones de colores para una máxima personalización!

DE > Das Schreibgerät par excellence unter den Werbegeschenken, die Nummer Eins unserer Kunden, **das Original**. Vielfältige **Druckmöglichkeiten** auf Schaft und Clip in **bis zu 4 Farben** und **tausende von Farbkombinationen** für maximale Personalisierung!

IT > Lo strumento di scrittura promozionale per eccellenza, il nostro numero uno, **l'originale**. Molteplici **possibilità di stampa** sul corpo e sulla clip fino a **4 colori e migliaia di combinazioni di colore** per la massima personalizzazione!



50%

1025

- Ballpen
- Bille
- Bolígrafo
- Kugelschreiber
- Penna a sfera

1028

- Mechanical pencil
- Porte-mine
- Portaminas
- Druckbleistift
- Portamine

A / C >

SP: max. 4 colours

B >

SP: max. 2 colours

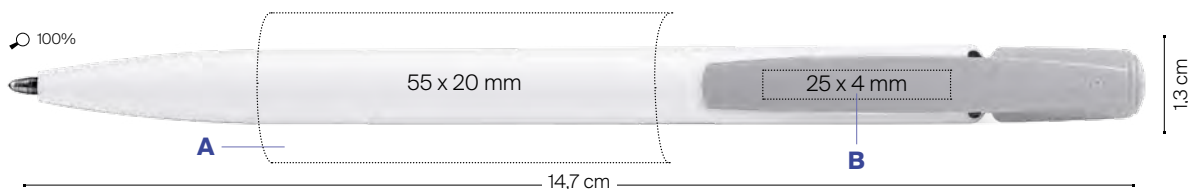

1025 / 1028

Clip and Plug
OPAQUE



FROSTED

Barrel
OPAQUE



FROSTED



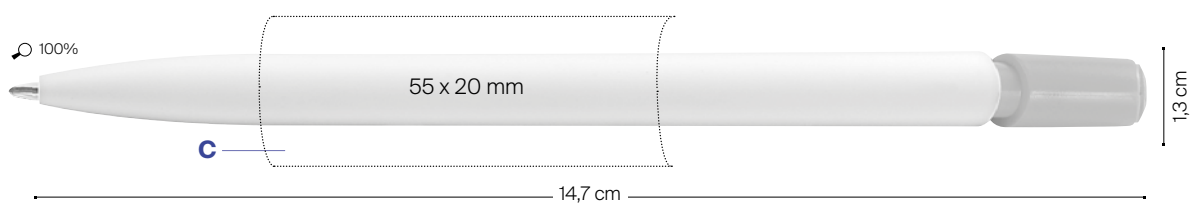

MOQ: 500 u.

PMS SERVICE
 ≥10.000 u.



Red ink available under request



Media Clic

ecolutions®

- EN >** The promotional writing instrument of excellence, our number one, **the original**. Multiple **printing possibilities** on the barrel in up to 4 colours imprint and on the clip, **and thousands of colour combinations** for maximum personalisation!
- FR >** L'instrument d'écriture promotionnel par excellence, notre favori, **l'original**. De nombreuses **possibilités d'impression** sur le corps et le clip **et des milliers de combinaisons** de teintes pour une personnalisation maximale !
- ES >** El instrumento de escritura promocional por excelencia, nuestro número uno, **el original**. Múltiples **posibilidades de impresión** en el cuerpo y en el clip en hasta 4 colores **y miles de combinaciones** de colores para una máxima personalización!
- DE >** Das Schreibgerät par excellence unter den Werbegeschenken, die Nummer Eins unserer Kunden, **das Original**. Vielfältige **Druckmöglichkeiten** in bis zu 4 Farben auf Schaft und Clip und **tausende von Farbkombinationen**. Für maximale Personalisierung!
- IT >** Lo strumento di scrittura promozionale per eccellenza, il nostro numero uno, **l'originale**. Tante possibilità **di stampa** sulla clip e sul fusto fino a 4 colori, **e migliaia di combinazioni** di colori per la massima personalizzazione!



*** Made with 39% recycled material.**
The percentage is calculated based on the total weight of the product.

Add the Möbius loop to your artwork at no additional charge. Please be sure to specify "Print the Möbius loop" on your order. (Möbius loop imprint defaults to left-hand hand corner)



***1E25**
Ballpen
Bille
Bolígrafo
Kugelschreiber
Penna a sfera

***1E28**
Mechanical pencil
Porte-mines
Portaminas
Druckbleistift
Portamine

A / B >
SP: max. 4 colours
C >
SP: max. 2 colours

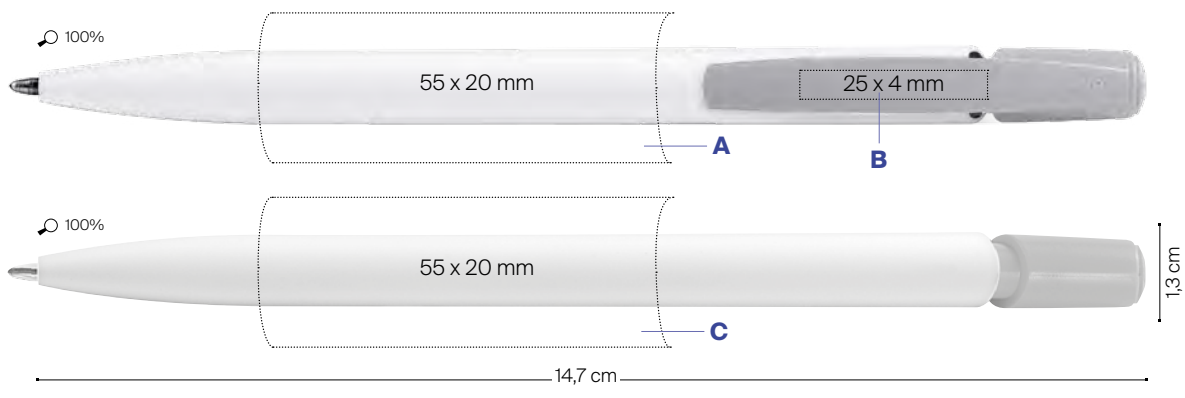

Clip and Plug
OPAQUE

01	02	2B	03	04	05	69
07	10	12	13	18	29	
2D	5C	3D	85	83	84	

FROSTED

1E	3E
----	----

MOQ: 500 u.
PMS SERVICE
≥10.000 u.

49h
M
MP
500
± 4,1 Kg
MADE IN SPAIN

If you want more information about our BIC® Ecolutions & how it's made visit: bicgraphic.eu/ie/sustainable-development.html.



Media Clic Digital



By the PIONEER...
In digital printing

BALLPENS

BIC® WRITING INSTRUMENTS

- EN >** The promotional writing instrument of excellence, our number one, the original. Now you can get fantastic results in digital printing on the barrel, **maximise the impact of your message at an affordable price!**
- FR >** Notre instrument d'écriture promotionnel par excellence, notre numéro 1, l'original. Désormais, vous pouvez obtenir de superbes finitions en impression numérique sur le corps. **Maximisez l'impact de votre message à un prix accessible!**
- ES >** Nuestro instrumento de escritura por excelencia, nuestro número uno, el original. Ahora puedes tener fantásticos acabados en impresión digital en el cuerpo, **¡maximiza el impacto de tu mensaje a un precio asequible!**
- DE >** Das Schreibgerät der Spitzenklasse unter den Werbeartikeln, unsere Nummer Eins, das Original. Sie erhalten jetzt fantastische digitale Druckergebnisse auf dem Schaft. **Maximieren Sie die Wirkung Ihrer Botschaft zu einem erschwinglichen Preis!**
- IT >** Lo strumento di scrittura promozionale di eccellenza, il nostro numero uno, l'originale. Ora puoi ottenere **risultati fantastici nella stampa digitale sul fusto e ottimizzare l'impatto del tuo messaggio a un prezzo abbordabile!**



1024

1029

1024

Ballpen
Bille
Bolígrafo
Kugelschreiber
Penna a sfera

1029

Mechanical pencil
Porte-mines
Portaminas
Druckbleistift
Portamine

A>

DG: full-colour

B>

SP: max. 2 colours

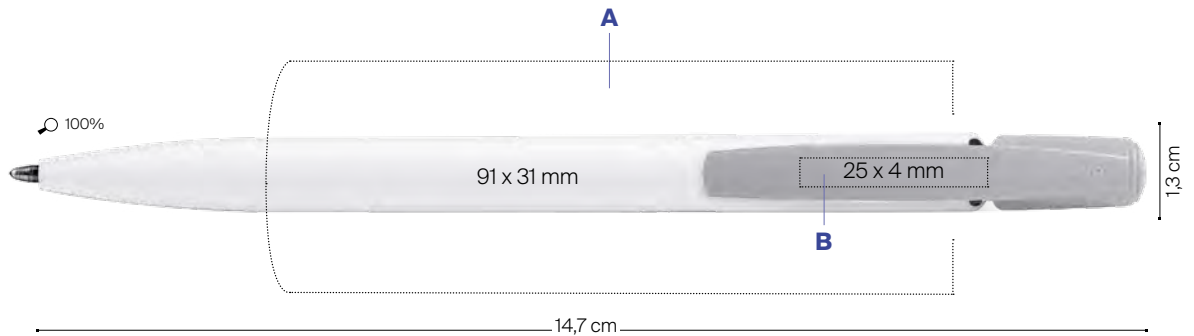

Clip and Plug
OPAQUE



FROSTED

69

Barrel
OPAQUE

01

MOQ: 500 u.

PMS SERVICE
≥10.000 u.



Red ink available under request

 **Media Clic Grip**





MIX & MATCH

Media Clic Grip

- EN >** Reliable plunger action mechanism with **soft touch grip section**, and **up to 4 colours imprint** available on the barrel!
- FR >** Mécanisme de rétraction fiable par poussoir, **grip à la texture douce** et possibilité d'imprimer jusqu'à **4 couleurs** sur le corps !
- ES >** ¡Mecanismo fiable de accionamiento retráctil en el pulsador con **grip de tacto suave**, y posibilidad de imprimir hasta **4 colores** en el cuerpo!
- DE >** Zuverlässiges Druckschreibgerät mit **Soft-Touch-Griffzone**. Der Schaft kann mit **bis zu 4 Farben** bedruckt werden!
- IT >** Affidabile meccanismo a scatto con **morbida impugnatura** e possibilità di stampa fino a 4 colori sul corpo!



BALLPENS

BIC® WRITING INSTRUMENTS

1020

Ballpen
Bille
Bolígrafo
Kugelschreiber
Penna a sfera

100%

1021

Mechanical pencil
Porte-mines
Portaminas
Druckbleistift
Portamine

100%

A / C >

SP: max. 4 colours

B >

SP: max. 2 colours

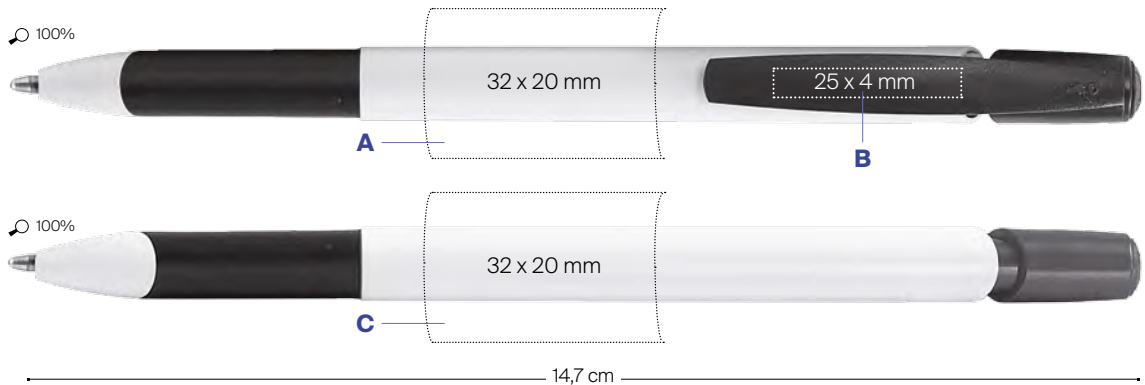

Clip and Plug
OPAQUE



FROSTED

Barrel and Grip
OPAQUE



Barrel and Grip
FROSTED

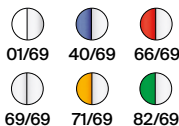

MOQ: 500 u.

PMS SERVICE
≥20.000 u.



Red ink available under request

500
±4.3 Kg





MIX & MATCH

Media Clic Grip

ecolutions®

- EN >** Reliable plunger action mechanism with **soft touch grip section, and up to 4 colours imprint** available on the barrel.
- FR >** Mécanisme fiable et rétractable par appui sur le poussoir. **Grip au toucher doux.** Nous pouvons désormais imprimer jusqu'à 4 couleurs sur le corps.
- ES >** Fiable mecanismo de accionamiento retráctil en el pulsador. **Sección con grip de tacto suave.** Es posible imprimir hasta 4 colores en el cuerpo.
- DE >** Zuverlässiges Druckschreibgerät mit **Soft-Touch-Griffzone.** Der Schaft kann mit bis zu 4 Farben bedruckt werden!
- IT >** Affidabile meccanismo a scatto. **impugnatura morbida al tatto.** Disponibile anche stampa in **quadricromia** sul fusto.



* **Made with 37% recycled material.**
The percentage is calculated based on the total weight of the product.

Add the Möbius loop to your artwork at no additional charge. Please be sure to specify "Print the Möbius loop" on your order. (Möbius loop imprint defaults to left-hand hand corner.)



***1E20**

Ballpen
Bille
Bolígrafo
Kugelschreiber
Penna a sfera

***1E21**

Mechanical pencil
Porte-mines
Portaminas
Druckbleistift
Portamine

A >
SP: max. 2 colours
B / C >
SP: max. 4 colours

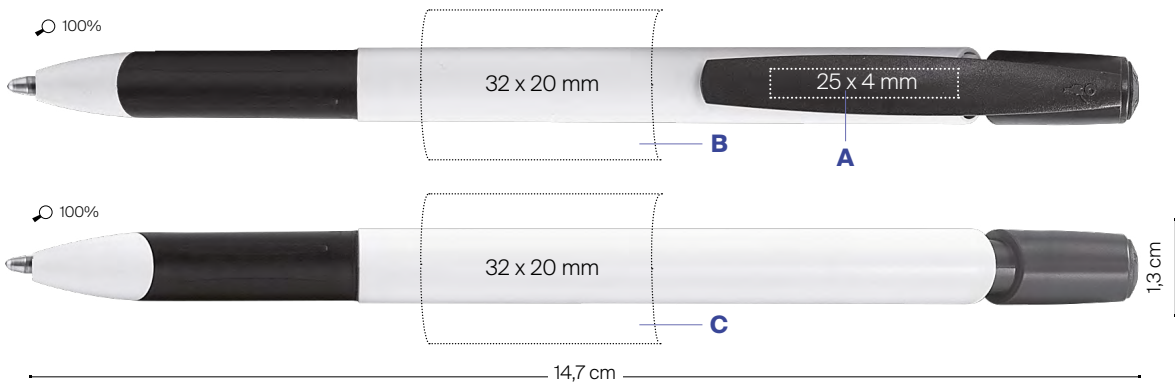

Clip and Plug
OPAQUE



FROSTED

Barrel and Grip
OPAQUE



MOQ: 500 u.

PMS SERVICE
≥10.000 u.



Red ink available under request

If you want more information about our BIC® Ecolutions & how it's made
visit: bicgraphic.eu/ie/sustainable-development.html.



MIX & MATCH

Media Clic Grip Digital

By the PIONEER...
In digital printing

EN > Reliable plunger action mechanism with soft touch grip section, and **360° full-colour imprint available on all frosted and opaque barrel colours!** Reinventing the digital imprint to maximize your personalisation options.

FR > Mécanisme de rétraction par poussoir, grip à la texture douce et **possibilité d'impression à 360° pour toute couleur, sur tous les corps de stylo, qu'ils soient opaques ou givrés!** Nous réinventons l'impression numérique pour optimiser les options de personnalisation.

ES > Mecanismo de accionamiento retráctil en el pulsador con grip de tacto suave, **posibilidad de impresión de 360° a todo color en todos los cuerpos ¡tanto opacos como traslúcidos!** Reinventando la impresión digital para maximizar las opciones de personalización.

DE > Zuverlässiges Druckschreibgerät mit Soft-Touch-Griffzone. **360° Vollfarb-Druck für alle gefrosteten und opaken Schafffarben!** Die Neuerfindung des Digitaldrucks, um Ihre Personalisierungsoptionen zu maximieren.

IT > Meccanismo a scatto con impugnatura morbida e **possibilità di stampa a 360° a colori su tutte le superfici, opache o frost!** Reinventare la stampa digitale per massimizzare la personalizzazione.



1886

Ballpen
Bille
Bolígrafo
Kugelschreiber
Penna a sfera

1887

Mechanical pencil
Porte-mines
Portaminas
Druckbleistift
Portamine

100%

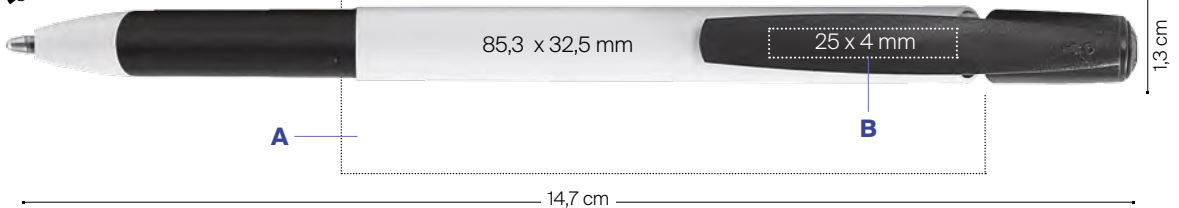

A >

DG: full-colour

B >

SP: max. 2 colours

Clip and Plug
OPAQUE



FROSTED

Barrel and Grip
OPAQUE



Barrel and Grip
FROSTED

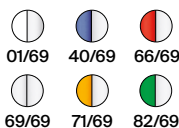

MOQ: 500 u.

PMS SERVICE
≥ 20.000 u.



Red ink available under request

500

± 4,3 Kg





MIX & MATCH

Media Clic Grip Digital eCOlutions®

- EN > Reliable plunger action mechanism with soft touch grip section, and **360° full-colour imprint available.**
- FR > Mécanisme de rétraction fiable par poussoir, grip à texture douce et **possibilité d'imprimer à 360° dans toutes les couleurs.**
- ES > Fiable mecanismo de accionamiento retráctil en el pulsador con sección con grip de tacto suave y **disponible con impresión 360° a todo color.**
- DE > Zuverlässiges Druckschreibgerät mit Soft-Touch-Griffzone. **Jetzt mit 360° Vollfarbdruck personalisierbar.**
- IT > Affidabile meccanismo a scatto con impugnatura morbida e **stampa multicolour a 360°.**

* **Made with 37% recycled material.**
The percentage is calculated based on the total weight of the product.

By the PIONEER...
In digital printing



***1E22**
Ballpen
Bille
Bolígrafo
Kugelschreiber
Penna a sfera

***1E23**
Mechanical pencil
Porte-mines
Portaminas
Druckbleistift
Portamine

A>
DG: full-colour
B>
SP: max. 2 colours

Add the Möbius loop to your artwork at no additional charge. Please be sure to specify "Print the Möbius loop" on your order. (Möbius loop imprint defaults to left-hand corner.)



Clip and Plug
OPAQUE

1E	02	2B	03	04	05	69
07	10	12	13	18	29	
2D	5C	3D	85	83	84	

FROSTED

Barrel and Grip
OPAQUE

01/02	01/03	01/05
01/07	01/12	



MOQ: 500 u.
PMS SERVICE
≥ 20,000 u.



Red ink available under request

If you want more information about our BIC® Ecolutions & how it's made
visit: bicgraphic.eu/ie/sustainable-development.html.



MIX & MATCH

Media Clic Premium

EN > Luxurious and affordable. Exclusive and versatile. **The premium version of the iconic BIC® Media Clic** aspires to be the ideal gift pen as well as to fit any budget.

FR > Effet chic à un prix accessible. À la fois exclusif et multifonction. **La version Premium de l'emblématique BIC® Media Clic** est le stylo idéal à offrir, parfait pour toutes les bourses.

ES > Lujoso a la vez que asequible. Exclusivo a la vez que versátil. **La versión Premium del icónico BIC® Media Clic** se convierte en el bolígrafo más adecuado para regalar, ideal para todos los bolsillos.

DE > Luxuriös und erschwinglich. Exklusiv und vielseitig. **Die Premiumversion der Ikone BIC® Media Clic** ist das ideale Schreibgeräte-Geschenk und passt auch noch in jedes Budget.

IT > Lussuosa e accessibile. Esclusiva e versatile. **La versione Premium della classica BIC® Media Clic** diventa una penna ideale da regalare, perfetta per tutte le tasche.



BALLPENS

BIC® WRITING INSTRUMENTS

100%

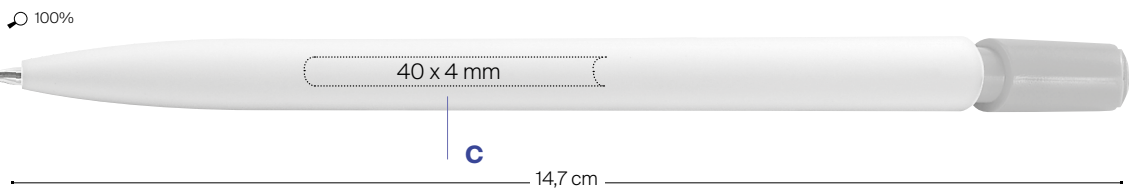
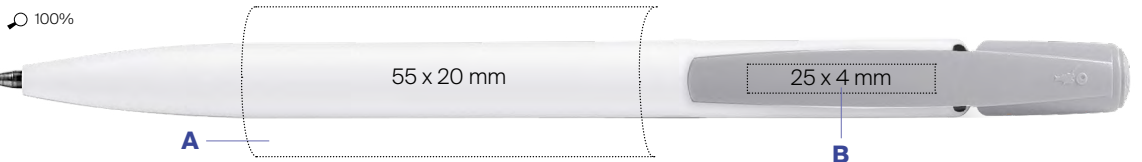

1D25
Ballpen
Bille
Bolígrafo
Kugelschreiber
Penna a sfera

A > SP: max. 4 colours

B > SP: max. 1 colours

C > LE

Clip



Plug



Barrel



MOQ: 500 u.



250
± 3,7Kg



Red ink available under request







Clic Stic

Modern, flexible, reliable. That's how BIC® Clic Stic is! A large variety of finishes such as Digital, Stylus, Softfeel® or Mini, and thousands of colour combinations!



Clic Stic



EN > Modern, flexible, reliable. That's how BIC® Clic Stic is! A large **variety of finishes** such as Digital, Stylus, Softfeel® or Mini, and **thousands of colour combinations!**

FR > Moderne, fiable, flexible. C'est la définition même du BIC® Clic Stic ! Une grande **variété de finitions** telles que Digital, Stylus, Softfeel® ou Mini, **et plus de mille combinaisons de couleurs !**

ES > Moderno, flexible, fiable. ¡Así es el BIC® Clic Stic! Amplia **variedad de acabados**, como Digital, Stylus, Softfeel® o Mini y **¡miles de combinaciones de colores!**

DE > Modern, flexibel, zuverlässig. So ist BIC® Clic Stic! In einer großen Vielfalt von Oberflächen wie Digital, Stylus, Softfeel® oder Mini, und in **Tausenden von Farbkombinationen erhältlich!**

IT > Moderna, flessibile, affidabile. Ecco com'è BIC® Clic Stic! Una grande varietà di rifiniture come Digital, Stylus, Softfeel® o Mini, **e migliaia di combinazioni di colore!**



1000

- Ballpen
- Bille
- Boligrafo
- Kugelschreiber
- Penna a sfera

- A>** SP: max. 3 colours
- B>** SP: max. 1 colour
- C>** SP: max. 2 colours

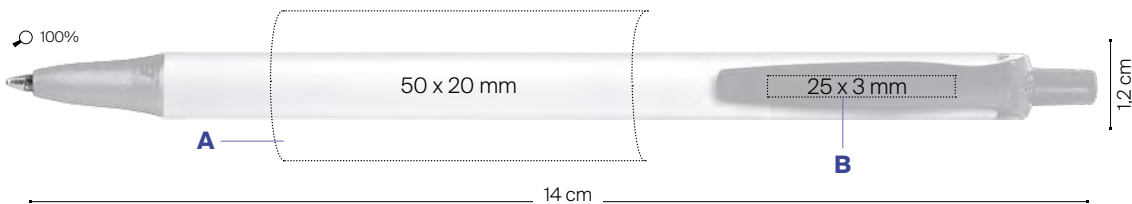

Cap, Section and Plug

OPAQUE				FROSTED			
01	02	03	04	40	63	66	
05	07	10	12	67	68	69	
18	20	71					

Barrel

OPAQUE				FROSTED			
01	02	03	40	63	66		
04	05	07	67	68	69		
12	18	71					

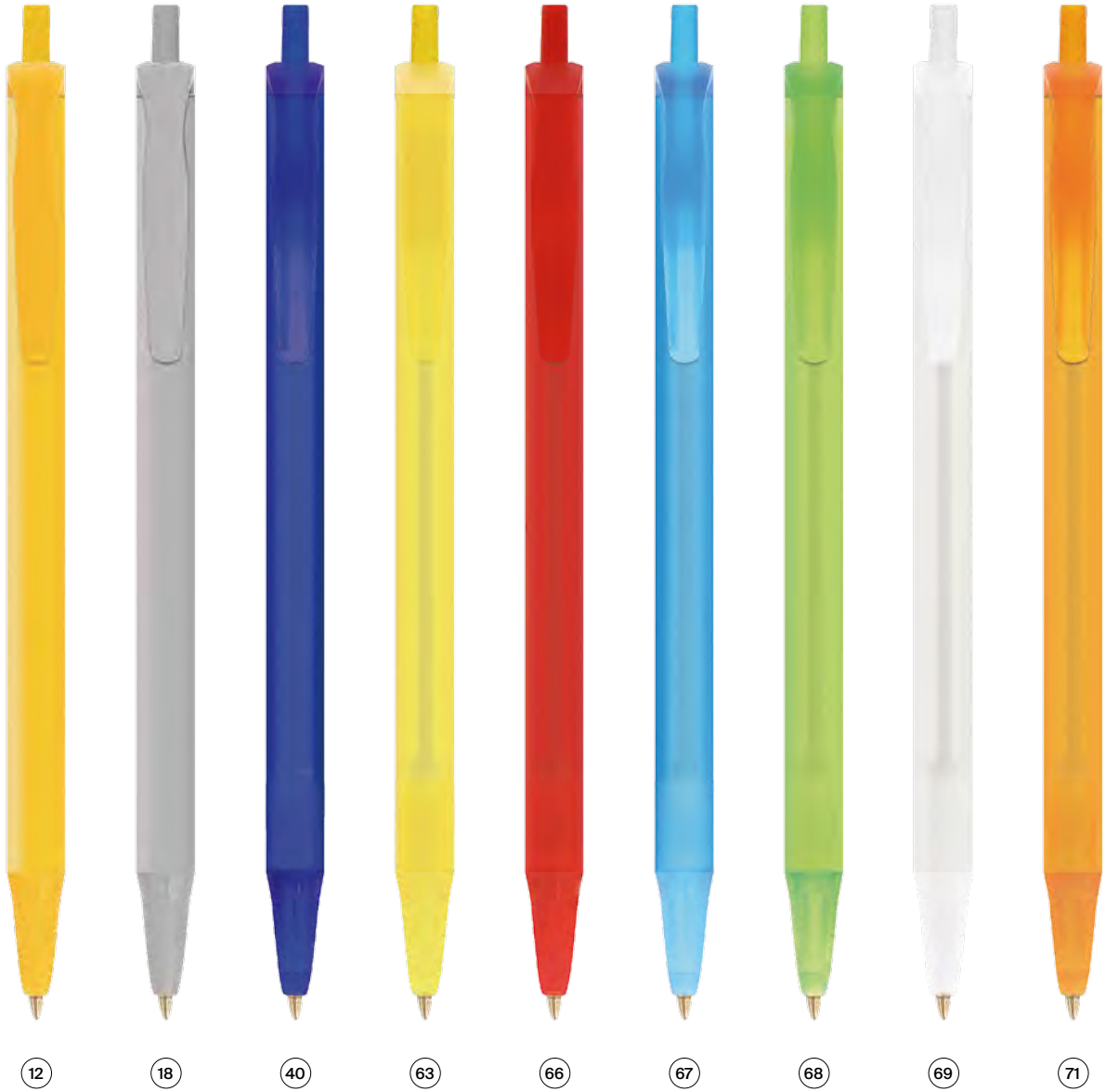

100%

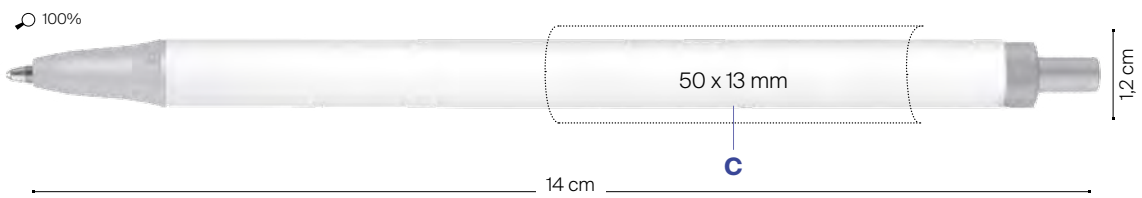

MOQ: 500 u.
 PMS SERVICE
 ≥10.000 u.



Red ink available under request

500
 ± 2,9Kg





Clic Stic ecoEvolution[®]



EN > Modern, flexible, reliable and committed to sustainability. Combine Mix&Match colour components with a large printing area to **maximise your message!**

FR > Moderne, fiable, flexible et engagé au niveau environnemental. Associez les composantes Mix&Match avec une large zone de marquage **pour donner plus d'impact à votre message !**

ES > Moderno, flexible, fiable y sosteniblemente comprometido. ¡Combina los componentes Mix&Match con una gran área de impresión **para maximizar tu mensaje!**

DE > Modern, flexibel, zuverlässig und zur Nachhaltigkeit verpflichtet. Kombinieren Sie Mix & Match Farbkomponenten mit einem großen Druckbereich, um **Ihre Botschaft zu maximieren!**

IT > Moderno, flessibile, affidabile ed eco sostenibile. Combina la soluzione Mix&Match con una grande area per la stampa **per massimizzare il tuo messaggio!**

*** Made with 58% recycled material.**
The percentage is calculated based on the total weight of the product.



Add the Möbius loop to your artwork at no additional charge. Please be sure to specify "Print the Möbius loop" on your order. (Möbius loop imprint defaults to left-hand hand corner.)



***1E00**

- Ballpen
- Bille
- Bolígrafo
- Kugelschreiber
- Penna a sfera

- A >**
- SP:** max. 3 colours
- B >**
- SP:** max. 1 colour
- C >**
- SP:** max. 2 colours

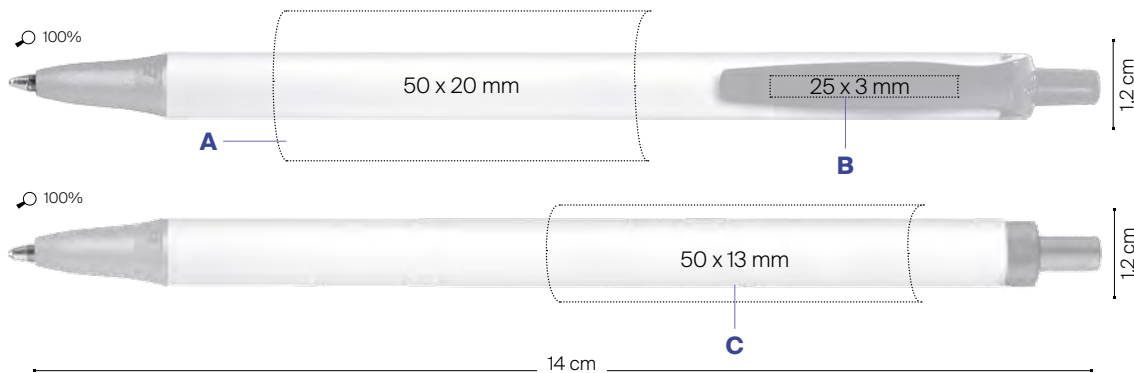

Cap and Section
OPAQUE



Barrel
OPAQUE FROSTED



MOQ: 500 u.

PMS SERVICE
≥10.000 u.



Red ink available under request

If you want more information about our BIC® Ecolutions & how it's made
visit: bicgraphic.eu/ie/sustainable-development.html.



Clic Stic Softfeel®

MIX & MATCH

EN > The **Softfeel®** rubberised barrel upgrades the writing experience by adding a **pleasant soft touch**.

FR > Le **corps** est recouvert de caoutchouc **Softfeel®**, qui assure **une expérience d'écriture douce et fluide par une prise en main agréable**.

ES > El **cuerpo** recubierto de goma **Softfeel®**, proporciona una **cálida y suave experiencia de escritura con un tacto agradable**.

DE > Der **gummierte Schaft des Softfeel®** wertet die Schreiberfahrung durch ihren angenehm **soften Touch** auf.

IT > Il **corpo** rivestito di gomma **Softfeel®**, offre una **calda e morbida esperienza di scrittura particolarmente gradevole al tatto**.



BALLPENS

BIC® WRITING INSTRUMENTS

1005
Ballpen
Bille
Bolígrafo
Kugelschreiber
Penna a sfera

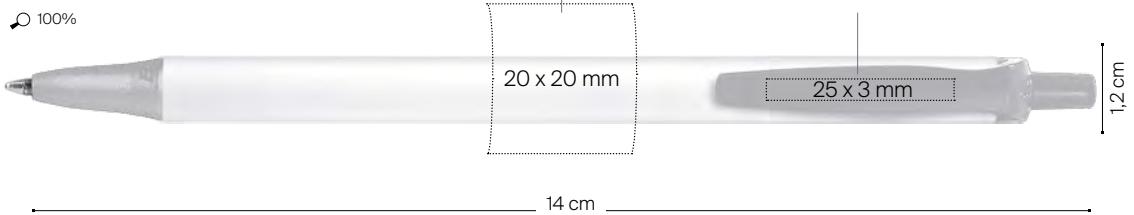

A/B >
SP: max. 1 colour

Clip and Section
OPAQUE



FROSTED

Barrel
OPAQUE



FROSTED



MOQ: 500 u.



+ 2,9 Kg



Red ink available under request





Clic Stic Digital & Mini Digital

- EN >** Combine Mix&Match colour components with a 360° photo quality **full-colour imprint to maximise your message!**
- FR >** Associez les composantes avec la technique Mix&Match, et imprimez toutes les couleurs à 360° avec une qualité photographique supérieure **pour donner plus d'impact à votre message!**
- ES >** Combina los componentes de Mix&Match e imprime a 360° con acabado fotográfico de alta calidad **a todo color para maximizar tu mensaje!**
- DE >** Kombinieren Sie die Farben mit Mix & Match im **360°-Vollfarbdruck in Fotoqualität, um Ihre Botschaft zu maximieren!**
- IT >** Combina i particolari con la tecnica Mix&Match e la stampa a 360° con alta qualità fotografica **a colori per massimizzare il tuo messaggio!**



1882

1882

1892

1882 / 1892 Mini Digital
Ballpen
Bille
Bolígrafo
Kugelschreiber
Penna a sfera

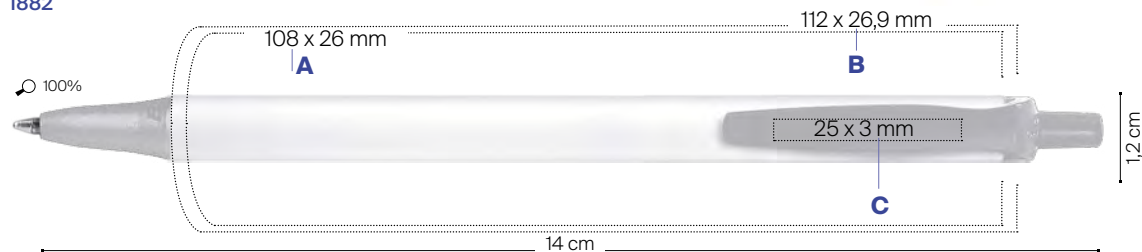

1892 Mini Digital

A / E >
DG: full-colour (area for text)
B / F >
DG: full-colour (area for images)
C >
SP: max. 1 colour

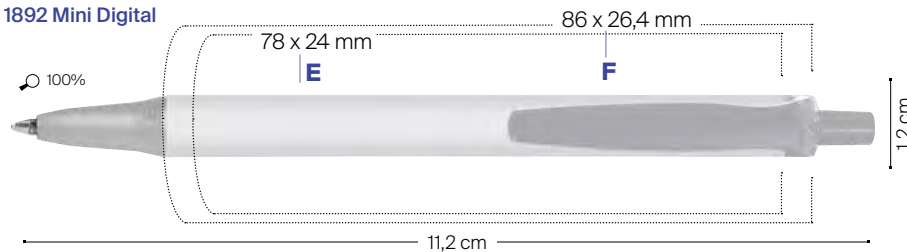

Clip and Section
OPAQUE

FROSTED

Barrel
OPAQUE



MOQ: 500 u.

PMS SERVICE
≥10.000 u.



Red ink available under request

1882 1892





MIX & MATCH

Clic Stic Digital ecolutions®

- EN >** Modern, flexible, reliable and committed to sustainability. Combine Mix&Match colour components with a 360° photo quality full-colour imprint to **maximise your message!**
- FR >** Moderne, fiable, flexible et engagé au niveau environnemental. Associez les composantes Mix&Match avec une impression à 360° dans toutes les couleurs **pour donner plus d'impact à votre message !**
- ES >** Moderno, flexible, fiable y sosteniblemente comprometido. ¡Combina los componentes Mix&Match con impresión 360° a todo color **para maximizar tu mensaje!**
- DE >** Modern, flexibel, zuverlässig und zur Nachhaltigkeit verpflichtet. Kombinieren Sie Mix & Match Farbkomponenten mit einem 360°-Vollfarbdruck in Fotoqualität, um Ihre **Botschaft zu maximieren!**
- IT >** Moderno, flessibile, affidabile ed eco sostenibile. Combina la soluzione Mix&Match con una grande area per la stampa multicolore a 360° per **massimizzare il tuo messaggio!**

* **Made with 58% recycled material.**

The percentage is calculated based on the total weight of the product.



BALLPENS

BIC® WRITING INSTRUMENTS

Add the Möbius loop to your artwork at no additional charge. Please be sure to specify "Print the Möbius loop" on your order. (Möbius loop imprint defaults to left-hand hand corner.)



*1E01
Ballpen
Bille
Bolígrafo
Kugelschreiber
Penna a sfera

A>
SP: max. 1 colour
B>
DG: full-colour
(area for images)
C>
DG: full-colour
(area for text)

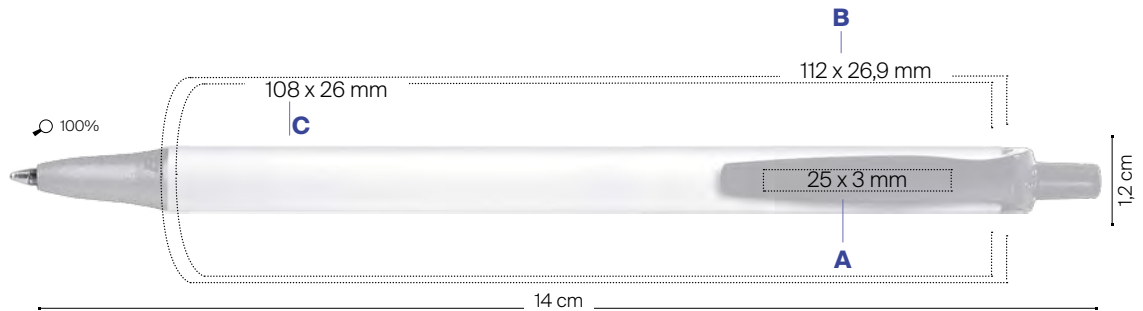

Cap and Section
OPAQUE



Barrel
OPAQUE



MOQ: 500 u.

PMS SERVICE
≥10.000 u.



500
±2,9 Kg



Red ink available under request

If you want more information about our BIC® Ecolutions & how it's made
visit: bicgraphic.eu/ie/sustainable-development.html.



Clic Stic Stylus

By the expert in...
Writing Instruments



EN > BIC® Clic Stic meets the coolest trends in writing instruments: stylus and produced in Europe. **A qualitative multi-function ballpen under the BIC® brand at a competitive price!**

FR > BIC® Clic Stic suit les toutes dernières tendances en matière d'écriture : en effet, c'est un stylo fabriqué en Europe. **Un stylo-bille multifonction et de qualité, de la marque BIC®, à un prix très compétitif !**

ES > BIC® Clic Stic sigue las últimas tendencias en instrumentos de escritura: stylus + producido en Europa. **¡Un bolígrafo multifunción de valor añadido bajo la marca BIC®, a un precio muy competitivo!**

DE > BIC® Clic Stic verkörpert den coolsten Trend bei Schreibgeräten: Stylus, hergestellt in Europa. **Ein hochwertiger Multifunktions-Kugelschreiber der Marke BIC® zum attraktiven Preis!**

IT > BIC® Clic Stic rispetta le ultime tendenze in fatto di scrittura: stylus + produzione Europea. **Una penna di qualità multifunzione di marca BIC® a un prezzo molto competitivo!**



100%

1847

Ballpen
Bille
Bolígrafo
Kugelschreiber
Penna a sfera



A>
SP: max. 3 colours

B>
SP: max. 1 colour

C>
SP: max. 2 colours

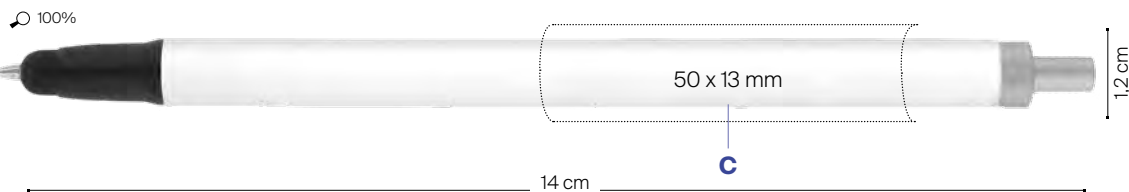

Clip
OPAQUE



FROSTED



Barrel
OPAQUE



Section
OPAQUE



MOQ: 500 u.



±2,9 Kg



Red ink available under request





MIX & MATCH

Clic Stic Stylus Digital

By the PIONEER...
In digital printing

- EN >** 360° full-colour imprint on a stylus ballpen produced in Europe. BIC® branded at a competitive price.
- FR >** Impression à 360° dans toutes les couleurs sur le stylo-bille Stylus de la marque BIC fabriqué en Europe, à un prix très compétitif !
- ES >** Impresión 360° a todo color en el bolígrafo Stylus producido en Europa bajo la marca BIC® ¡a un precio competitivo!
- DE >** 360°-Vollfarbdruck auf einem Stylus-Kugelschreiber der Marke BIC®. Hergestellt in Europa zum attraktiven Preis!
- IT >** Stampa a 360° a colori sulla penna Stylus prodotta in Europa a marchio BIC® ad un prezzo competitivo!



BALLPENS

BIC® WRITING INSTRUMENTS

- 1848
- Ballpen
- Bille
- Bolígrafo
- Kugelschreiber
- Penna a sfera

- A>**
- DG:** full-colour (area for text)
- B>**
- DG:** ful-colour (area for images)
- C>**
- SP:** max. 1 colour

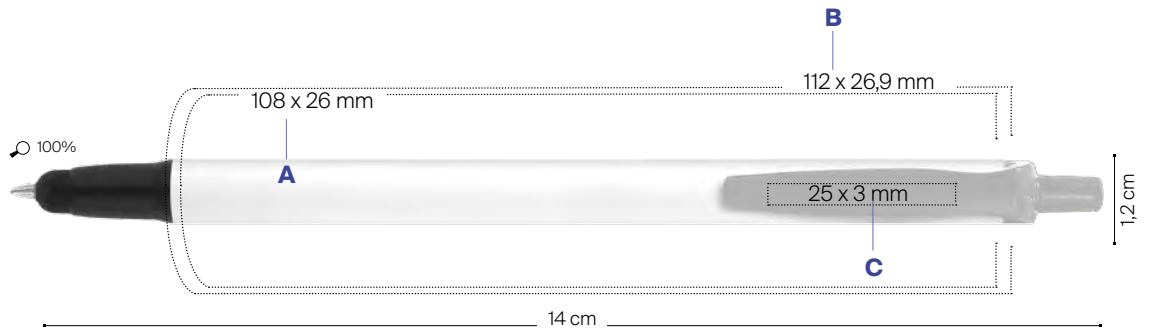

- Clip
OPAQUE
- | | | | |
|----|----|----|----|
| 01 | 02 | 03 | 04 |
| 05 | 07 | 10 | 12 |
| 18 | 20 | | |
- FROSTED
- | | | |
|----|----|----|
| 40 | 63 | 66 |
| 67 | 68 | 69 |
| 71 | | |

- Barrel
OPAQUE
- 01
- Section
OPAQUE
- 02



MOQ: 500 u.
PMS SERVICE
≥10,000 u.



500
± 2,9 Kg

MADE IN SPAIN



Red ink available under request





Super Clip

Stylish design meets versatility.
Many possibilities thanks to the
wide variety of colours and the
large printing areas!



Super Clip

MIX & MATCH

EN > Stylish design meets versatility. Many possibilities thanks to the **wide variety of colours and the large printing areas!**

FR > Design élégant et multifonction. De nombreuses possibilités grâce à la **grande variété de couleurs et aux larges zones d'impression !**

ES > Diseño elegante y versátil. ¡Muchas posibilidades gracias a la **gran variedad de colores y la gran área de impresión!**

DE > Stylishes Design trifft auf Vielseitigkeit. Vielfältige Möglichkeiten dank der **breiten Farbauswahl und der großen Druckflächen!**

IT > Design elegante e versatile. Molte possibilità grazie alla **grande varietà di colori e alle grandi aree di stampa!**



50%

1039

Ballpen
Bille
Bolígrafo
Kugelschreiber
Penna a sfera

A > SP: max. 2 colours
B > SP: max. 1 colour

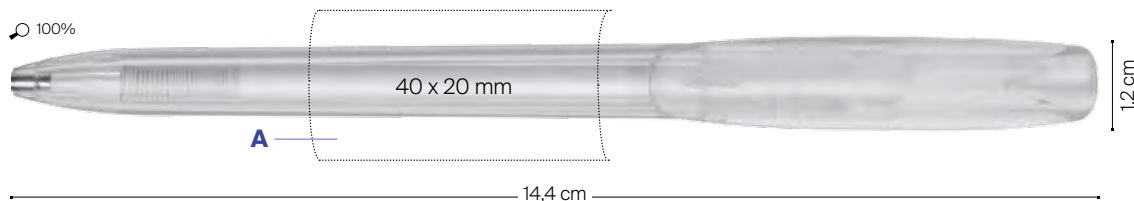

Clip and Barrel
OPAQUE



CLEAR





1G

1P

2F

2G

3H

8D



51



86



87



88



89



92



93



95

50%



100%

39,3 x 9 mm

B

14,4 cm

1,2 cm

MOQ: 250 u.

PMS SERVICE
≥10.000 u.



250
+2,6 Kg





Super Clip

britePix™

EN > Make the most out of the large printing area on the clip with the britePix™ full-colour imprint. Also available with the britePix™ Texture that gives a relief effect on your communication!

FR > Profitez au maximum de la large zone d'impression du clip, la technique d'impression britePix™ dans toutes les couleurs. Aujourd'hui également disponible avec britePix™ Texture, qui apporte du relief à votre communication !

ES > Aprovecha al máximo la gran área de impresión del clip con la técnica de impresión britePix™ a todo color. También disponible con britePix™ Texture que le dará un efecto relieve a tu comunicación!

DE > Holen Sie mit dem britePix™-Vollfarbdruck alles aus der großen Druckfläche auf dem Clip heraus. Auch mit britePix™-Texture erhältlich, das Ihrer Botschaft einen Relief-Effekt verleiht!

IT > Sfrutta al massimo la grande area di stampa della clip con la tecnica di stampa full-colour britePix™. Disponibile anche con britePix™ Texture per dare rilievo alla tua comunicazione!

MIX & MATCH

britePix™ Texture



100%

1894 britePix™

- Ballpen
- Bille
- Bolígrafo
- Kugelschreiber
- Penna a sfera

- A> SP: max.2 colours
- B> BP: full-colour
- C> BP Texture: full-colour

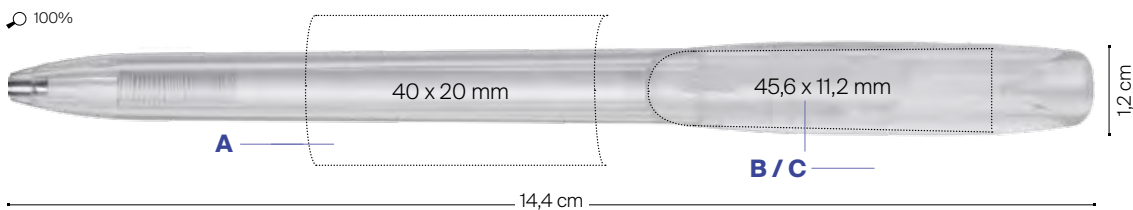

Clip and Barrel
OPAQUE

CLEAR



MOQ: 250 u.

PMS SERVICE
≥10.000 u.



250
±2,6 Kg





Super Clip **eco**olutions® & **britePix**™ **eco**olutions®

By the expert in...
Writing Instruments



EN > Make the most of the large printing area on the clip with the **britePix**™ full-colour imprint. Also available with the **britePix**™ **Texture** that gives a relief effect on your communication!

FR > Profitez au maximum de la large zone d'impression du clip, avec la technique d'impression **britePix**™ dans toutes les couleurs. **Egalement disponible avec britePix**™ **Texture**, qui apporte du relief à votre communication !

ES > Aprovecha al máximo la gran área de impresión del clip con la técnica de impresión **britePix**™ a todo color. **También disponible con britePix**™ **Texture**, que le dará un efecto relieve a tu comunicación!

DE > Holen Sie mit dem **britePix**™-Vollfarbdruck alles aus der großen Druckfläche auf dem Clip heraus. Auch mit **britePix**™ **Texture** erhältlich, das Ihrer Botschaft einen Relief-Effekt verleiht!

IT > Sfrutta al massimo la grande area di stampa della clip con la tecnica di stampa full-colour **britePix**™. **Disponibile anche con britePix**™ **Texture** che dona alla tua comunicazione un effetto a rilievo!

*** Made with 50% recycled material.**

The percentage is calculated based on the total weight of the product.

Add the Möbius loop to your artwork at no additional charge. Please be sure to specify "Print the Möbius loop" on your order. (Möbius loop imprint defaults to left-hand hand corner)



100%
1E51



100%
1E50



100%
1E51

***1E50 / *1E51 **britePix**™**
Ballpen
Bille
Bolígrafo
Kugelschreiber
Penna a sfera

A > SP: max. 2 colours
B > SP: max. 1 colour
C > BP: full-colour
D > BP Texture: full-colour

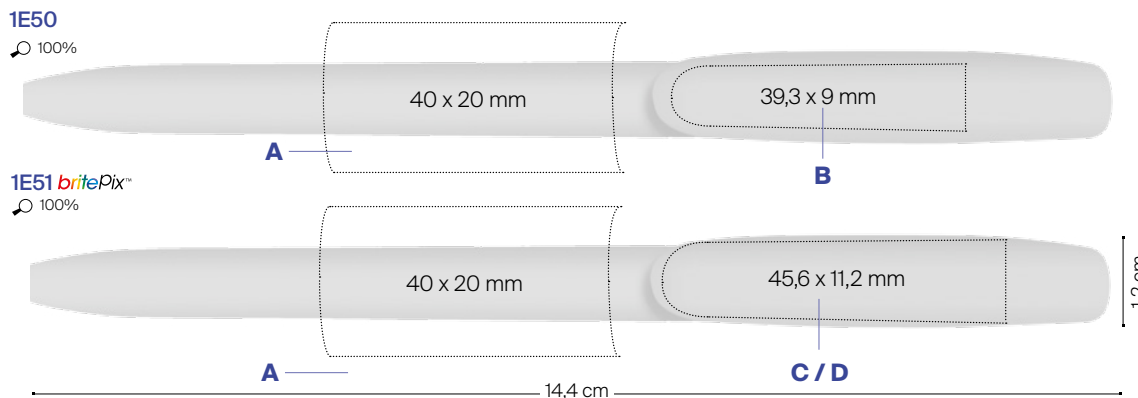

Barrel
OPAQUE



MOQ: 250 u.

PMS SERVICE
≥10.000 u.



* 1E50



250
±2,6 Kg



If you want more information about our BIC® Ecolutions & how it's made
visit: bicgraphic.eu/ie/sustainable-development.html.



By the expert in...
In digital printing



Super Clip Digital & britePix™ Digital

- EN /** Endless possibilities combining the 360° full-colour imprint on the barrel and the britePix™ full-colour imprint on the clip! Also available with the britePix™ Texture that gives a relief effect on your communication!
- FR /** Des possibilités infinies qui associent l'impression à 360° sur tout le corps du stylo, et avec la technique britePix™ pour toutes les couleurs sur le clip! **Disponible avec britePix™ Texture**, qui apportera du volume à votre communication!
- ES /** ¡Un sinfín de posibilidades que combina la impresión 360° a todo color en el cuerpo, con la técnica britePix™ a todo color en el clip! También disponible con britePix™ Texture, ¡que añade volumen a tu comunicación!
- DE /** Entdecken Sie endlose Möglichkeiten, den 360°-Vollfarbdruck auf dem Schaft mit dem britePix™-Vollfarbdruck auf dem Clip zu kombinieren! **Auch mit britePix™ Texture erhältlich**, das Ihrer Botschaft einen Relief-Effekt verleiht!
- IT /** Infinite possibilità che combinano la stampa a 360° su tutto il corpo della penna, con la tecnica multicolour britePix™ sulla clip! **Disponible anche con britePix™ Texture**, per dare più volume alla tua comunicazione!

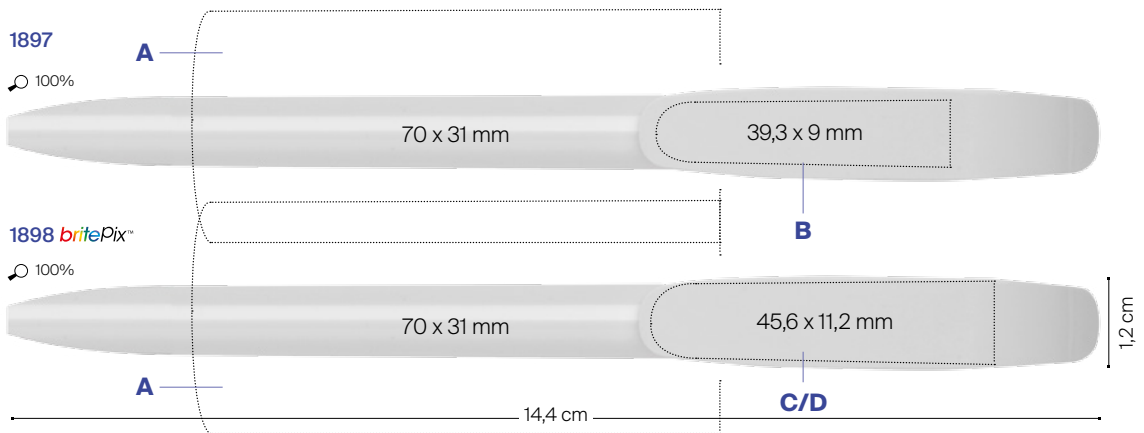

1897 / 1898 **britePix™**
Ballpen
Bille
Bolígrafo
Kugelschreiber
Penna a sfera

A> DG: full-colour
B> SP: max. 1 colour
C> BP: full-colour
D> BP Texture: full-colour

Clip and Barrel
OPAQUE



CLEAR

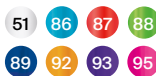

Barrel
OPAQUE



MOQ: 250 u.

PMS SERVICE
≥10.000 u.



250
+2,6 Kg





Super Clip Digital & britePix™ Digital

ecolutions®

EN / The recycled version of our top full-colour communicator! Stylish clip design with **britePix™ full-colour imprint combined with 360°** photo-quality full-colour imprint on the barrel.

FR / La version recyclée de notre meilleur outil de communication, dans toutes les couleurs ! Un clip soigné avec une impression **britePix™, et une impression à 360°** dans toutes les couleurs avec une qualité photographique sur le corps.

ES / ¡La versión reciclada de nuestro mejor comunicador a todo color! Un clip con estilo con impresión **britePix™ e impresión 360°** a todo color con calidad fotográfica en el cuerpo.

DE / Die Recyclingversion unseres beliebten, vollfarbigen Kommunikators! Stylishes Clip-Design mit **britePix™-Vollfarbdruck kombiniert mit 360°-Vollfarbdruck in Fotoqualität** auf dem Schaft realisierbar.

IT / La versione riciclata del nostro migliore strumento di comunicazione multicolore! Elegante design della clip personalizzata in **britePix™ e stampa multicolore a 360° sul fusto con qualità fotografica!**

*** Made with 50% recycled material.**

The percentage is calculated based on the total weight of the product.

Add the Möbius loop to your artwork at no additional charge. Please be sure to specify "Print the Möbius loop" on your order. (Möbius loop imprint defaults to left-hand hand corner)



1E53

1E52

1E53

100%

*1E52

100%

*1E52 / *1E53 britePix™

Ballpen
Bille
Bolígrafo
Kugelschreiber
Penna a sfera

*1E53 britePix™

100%

A> DG: full-colour
B> SP: max. 1 colour

C> BP: full-colour
D> BP Texture: full-colour

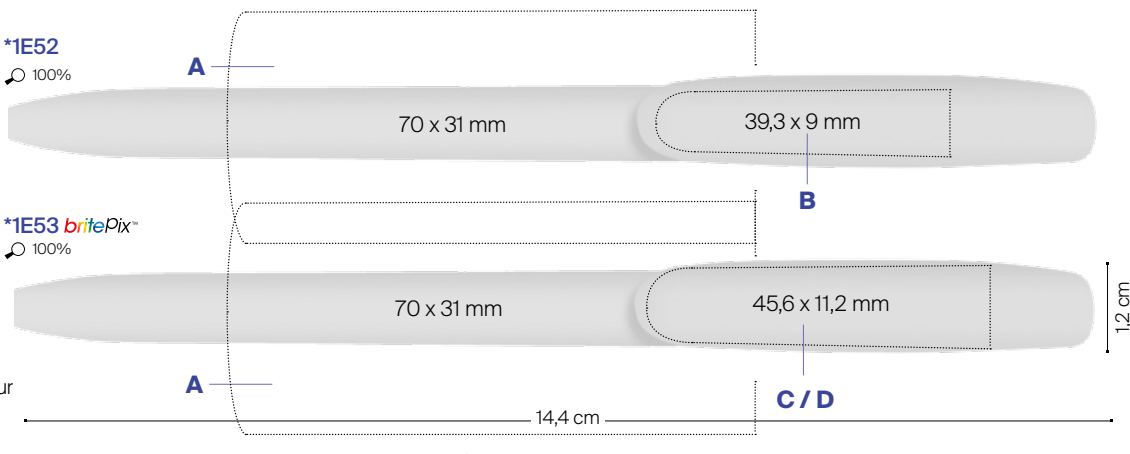

Barrel
OPAQUE

1E



MOQ: 250 u.

FMS SERVICE
≥10,000 u.



250
±2,6 Kg



If you want more information about our BIC® Ecolutions & how it's made visit: bicgraphic.eu/ie/sustainable-development.html.



Super Clip Advance

EN > Precise and comfortable writing experience. Add a premium look to your communication with this version with chrome-plated metal section.

FR > Une écriture plus confortable et précise, ajoutez un look Premium à votre communication avec cette version incluant une partie chromée argentée.

ES > Una escritura más cómoda y precisa, añadimos un look Premium a tu comunicación con esta versión con la sección plateada cromada.

DE > Erleben Sie präziseres und komfortableres Schreiben! Verleihen Sie Ihrer Botschaft einen Premium-Look durch diese Version mit verchromter Metallspitze.

IT > Una scrittura piú comoda e precisa. Dona un aspetto Premium alla tua comunicazione con questa versione con puntale in metallo cromato.



By the expert in...
Writing Instruments



100%

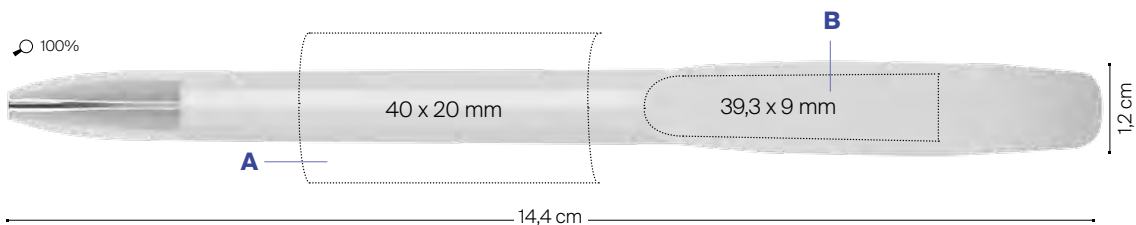

1073

Ballpen
Bille
Bolígrafo
Kugelschreiber
Penna a sfera

A> SP: max. 2 colours
B> SP: max. 1 colour

Clip
OPAQUE



CLEAR



Barrel
OPAQUE



Section



MOQ: 250 u.

PMS SERVICE
≥10.000 u.



250
±3,9 Kg





MIX & MATCH

Super Clip Advance britePix™

By the expert in...
Writing Instruments



BALLPENS

BIC® WRITING INSTRUMENTS

- EN>** Full-colour branding on the clip with a premium look. Also available with britePix™ Texture that gives a relief effect on your communication!
- FR >** Votre marque se décline sur le clip dans toutes les couleurs, un look premium. Aujourd'hui également disponible avec britePix™ Texture, qui apportera du relief à votre communication !
- ES>** Tu marca a todo color en el clip con un look premium. También disponible con britePix™ Texture que le dará efecto relieve a tu comunicación.
- DE>** Vollfarbiges Branding auf Clip im Premium-Look. Auch mit dem britePix™-Texture erhältlich, das Ihrer Botschaft einen Relief-Effekt verleiht!
- IT>** Il tuo marchio full-colour sulla clip con un look premium. Disponibile anche con britePix™ Texture per dare rilievo alla tua comunicazione.



100%

1074 britePix™
Ballpen
Bille
Bolígrafo
Kugelschreiber
Penna a sfera

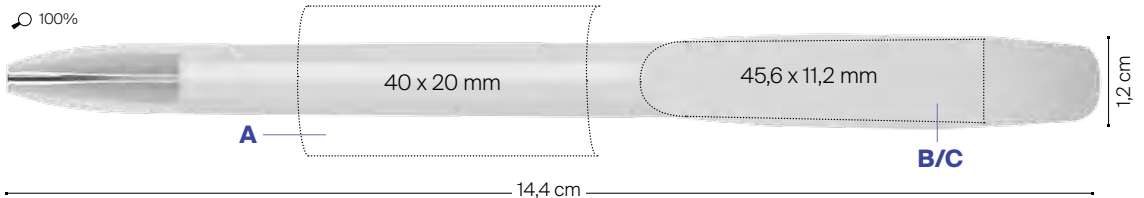

- A> SP: max. 2 colours
- B> BP: full-colour
- C> BP Texture: full-colour

Clip OPAQUE	CLEAR	Barrel OPAQUE	Section
01 02 03 04	51 86 87	01 02 03 04	35
06 07 27 1G	88 89 92	06 07 27 1G	
1P 2F 2G 3H	93 95	1P 2F 2G 3H	



MOQ: 250 u.

PMS SERVICE
≥ 10.000 u.



250
± 39 Kg





Super Clip Advance Digital

By the expert in...
In digital printing

- EN >** Our top full-colour communication welcomes a more comfortable writing and a premium look. Also **available with the britePix™ Texture that gives a relief effect on your communication!**
- FR >** Notre numéro un de la communication dans toutes les couleurs offre désormais une écriture plus confortable et une apparence premium. **Également disponible avec britePix™ Texture, qui apporte du relief à votre communication !**
- ES >** Nuestro número uno en comunicación a todo color, da la bienvenida a una escritura más confortable y una apariencia premium. **¡También disponible con britePix™ Texture que dará efecto relieve a tu comunicación!**
- DE >** Unser beliebter Botschafter im Vollfarbdruck bietet jetzt noch komfortableres Schreiben im Premium-Look. **Auch mit britePix™ Texture erhältlich, das Ihrer Botschaft einen Relief-Effekt verleiht!**
- IT >** Il nostro numero uno nella comunicazione a multicolour dà il benvenuto ad una scrittura più comoda e ad un aspetto premium. **Disponibile anche con britePix™ Texture per dare rilievo alla tua comunicazione!**



100%

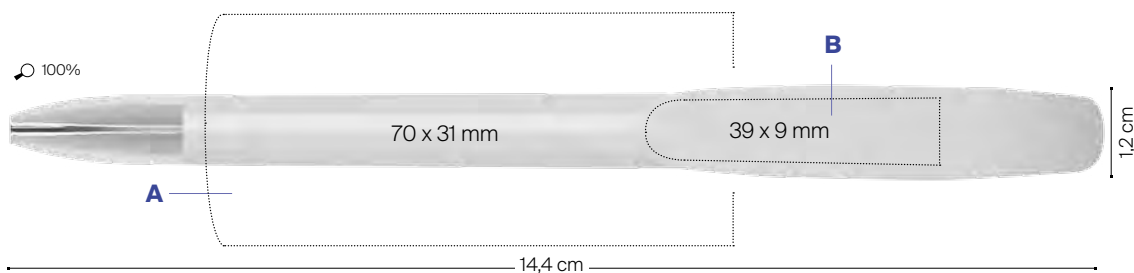

1076
Ballpen
Bille
Bolígrafo
Kugelschreiber
Penna a sfera

A > DG: full-colour
B > SP: max. 1 colour

Clip OPAQUE	CLEAR	Barrel OPAQUE	Section

MOQ: 250 u.

PMS SERVICE
≥ 10.000 u.



250
± 3,9 Kg





MIX & MATCH

Super Clip Advance britePix™ Digital

By the expert in...
In digital printing

BALLPENS

BIC® WRITING INSTRUMENTS

EN > Our top full-colour communication welcomes a more comfortable writing and a premium look. Also available with the britePix™ Texture that gives a relief effect on your communication!

FR > Notre numéro un de la communication dans toutes les couleurs offre désormais une écriture plus confortable et une apparence premium. Également disponible avec britePix™ Texture, qui apporte du relief à votre communication !

ES > Nuestro número uno en comunicación a todo color, da la bienvenida a una escritura más confortable y una apariencia premium. ¡También disponible con britePix™ Texture que dará efecto relieve a tu comunicación!

DE > Unser beliebter Botschafter im Vollfarbdruck bietet jetzt noch komfortableres Schreiben im Premium-Look. Auch mit britePix™ Texture erhältlich, das Ihrer Botschaft einen Relief-Effekt verleiht!

IT > Il nostro numero uno nella comunicazione a multicolour dà il benvenuto ad una scrittura più comoda e ad un aspetto premium. Disponibile anche con britePix™ Texture per dare rilievo alla tua comunicazione!

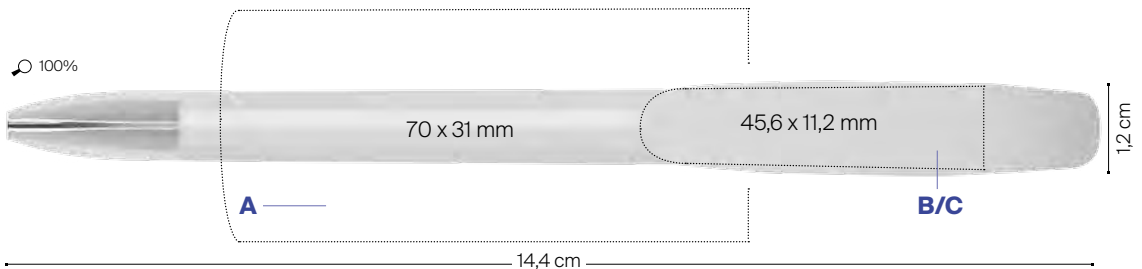

1075 britePix™
Ballpen
Bille
Bolígrafo
Kugelschreiber
Penna a sfera

A > DG: full-colour
B/C > BP: full-colour
BP Texture: full-colour

Clip OPAQUE	CLEAR	Barrel OPAQUE	Section
01 02 03 04	51 86 87	01	35
06 07 27 1G	88 89 92		
1P 2F 2G 3H	93 95		



MOQ: 250 u.

PMS SERVICE
≥ 10.000 u.



250
± 39 Kg
MADE IN SPAIN







Wide Body™

The right size for showing the true value of your brand! Wide profile and wide variety of possibilities to maximise your message.



Wide Body™

MIX & MATCH

By the expert in...
Writing Instruments



EN > The right size for showing the true value of your brand! Wide profile and wide variety of possibilities to **maximise your message.**

FR > Le format idéal pour montrer la vraie valeur de votre marque ! Profil large et grande variété de possibilités **pour donner plus d'impact à votre message.**

ES > ¡El tamaño adecuado para mostrar el verdadero valor de tu marca! Perfil ancho y gran variedad de posibilidades **para maximizar tu mensaje.**

DE > Die richtige Größe, um den wahren Wert Ihrer Marke zu zeigen! Breites Profil und umfassende Möglichkeiten, **Ihre Botschaft zu maximieren.**

IT > La dimensione giusta per mostrare il vero valore del tuo marchio! Profilo ampio e numerose possibilità **di massimizzare il tuo messaggio.**

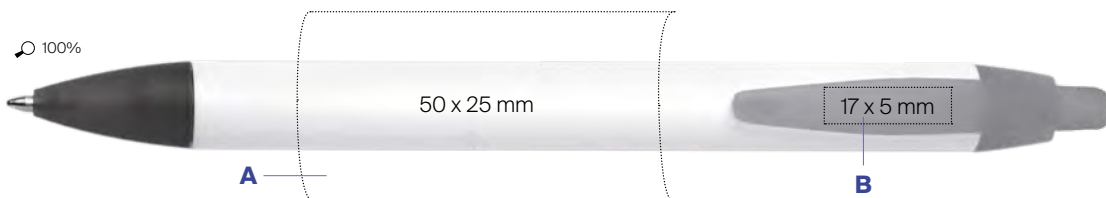

1080

Ballpen
Bille
Bolígrafo
Kugelschreiber
Penna a sfera

A / C > SP: max. 2 colours
B > SP: max. 1 colour

Barrel, Clip and Section
OPAQUE



FROSTED



MOQ: 250 u.

PMS SERVICE
≥ 10.000 u.

* ≥ 25.000 u. for custom made Section



Red ink available under request





MIX & MATCH

Wide Body™ ecolutions®

- EN >** The right size for showing the true value of your brand! **Wide profile and wide variety of possibilities to maximise your message.**
- FR >** Le format idéal pour montrer la vraie valeur de votre marque ! **Profil large et grande variété de possibilités pour donner plus d'impact à votre message.**
- ES >** ¡El tamaño adecuado para mostrar el verdadero valor de tu marca! **Perfil ancho y gran variedad de posibilidades para maximizar tu mensaje.**
- DE >** Die richtige Größe, um den wahren Wert Ihrer Marke zu zeigen! **Breites Profil und umfassende Möglichkeiten, Ihre Botschaft zu maximieren.**
- IT >** La dimensione giusta per mostrare il vero valore del tuo marchio! **Profilo ampio e numerose possibilità di massimizzare il tuo messaggio.**

* **Made with 33% recycled material.**
The percentage is calculated based on the total weight of the product.

Add the Möbius loop to your artwork at no additional charge. Please be sure to specify "Print the Möbius loop" on your order. (Möbius loop imprint defaults to left-hand hand corner)



BALLPENS

100%

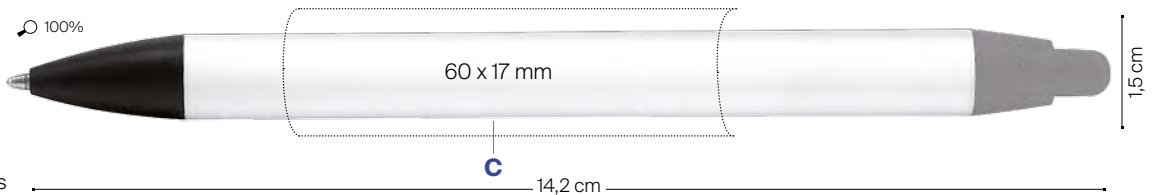
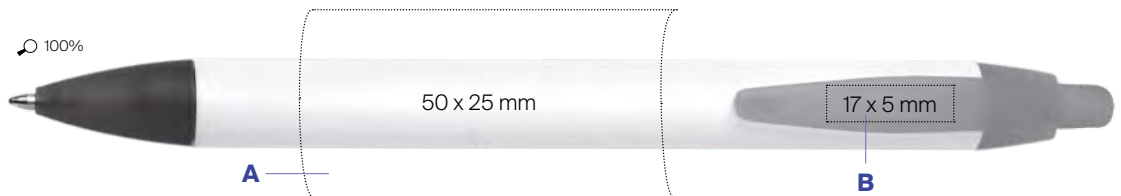

- *1E80
- Ballpen
- Bille
- Bolígrafo
- Kugelschreiber
- Penna a sfera

A / C > SP: max. 2 colours
B > SP: max. 1 colour

Clip and Section
OPAQUE



FROSTED



Barrel
OPAQUE



MOQ: 250 u.

PMS SERVICE
≥ 10.000 u.

* ≥ 25.000 u. for custom made Section



Red ink available under request



± 2.6 Kg



MADE IN SPAIN

If you want more information about our BIC® Ecolutions & how it's made
visit: bicgraphic.eu/ie/sustainable-development.html.



Wide Body™ Digital

By the expert in...
In digital printing

EN > Wide profile and the largest 360° imprint area in the market, with full-colour imprint available on all frosted and opaque barrel colours! Reinventing digital to maximize your personalisation options.

FR > Profil large avec zone de marquage à 360°, la plus large du marché, avec un marquage dans toutes les couleurs, disponible dans toutes les teintes de corps givrées et opaques! Nous réinventons le numérique pour optimiser les options de personnalisation.

ES > Perfil ancho con el área de marcado 360° más grande del mercado, con impresión a todo color (disponible en todos los colores de cuerpo frosted y opacos)! Reinventamos el digital para ampliar tu opciones de personalización.

DE > Breites Profil und die größte 360°-Druckfläche auf dem Markt, mit Vollfarbdruck für alle gefrosteten und opaken Schaftfarben! Die digitale Neuerung, um Ihre Personalisierungsoptionen zu maximieren.

IT > Profilo ampio con l'area di stampa a 360° più grande del mercato, con stampa multicolore in tutte le varianti frost e opache! Reinventiamo il digitale per aumentare le tue opzioni di personalizzazione.

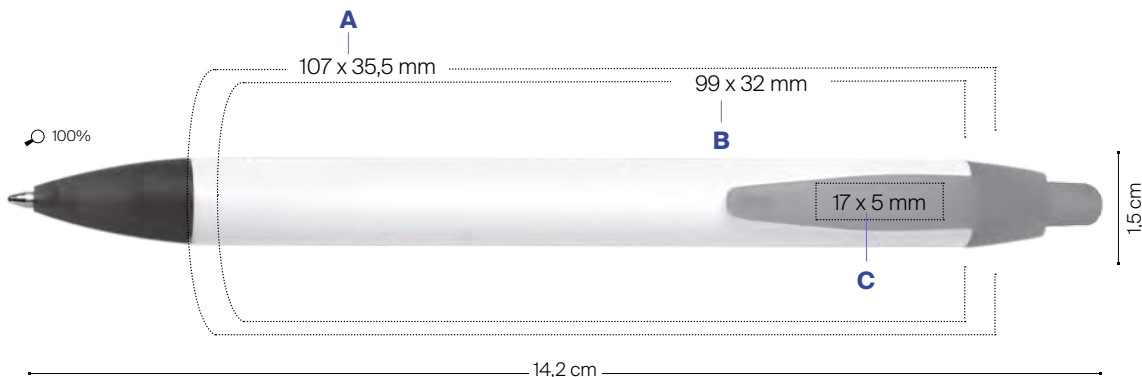

1878

- Ballpen
- Bille
- Bolígrafo
- Kugelschreiber
- Penna a sfera

A> DG: full-colour (area for images)

B> DG: full-colour (area for text)

C> SP: max. 1 colour

Barrel, Clip, Cover and Section
OPAQUE FROSTED

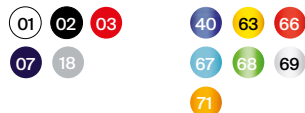

MOQ: 500 u.

PMS SERVICE
≥ 10.000 u.

*≥ 25.000 u. for custom made Section



± 2,6 Kg



Red ink available under request





MIX & MATCH

Wide Body™ Digital eColutions®

By the expert in...
In digital printing

BALLPENS

BIC® WRITING INSTRUMENTS

- EN >** The right size for showing the true value of your brand! **Wide profile and the largest 360° imprint area on the market!**
- FR >** Le format idéal pour montrer la vraie valeur de votre marque ! **Avec un profil large et la zone d'impression à 360° la plus large du marché !**
- ES >** ¡El tamaño adecuado para mostrar el verdadero valor de tu marca! **¡Con perfil ancho y el área de impresión 360° más grande del mercado!**
- DE >** Die richtige Größe, um den wahren Wert Ihrer Marke zu zeigen! **Breites Profil und die größte 360°-Druckfläche auf dem gesamten Markt!**
- IT >** La dimensione giusta per mostrare il vero valore del tuo marchio! **Profilo ampio e l'area di stampa a 360° più grande del mercato!**



100%

* **Made with 33% recycled material.**
The percentage is calculated based on the total weight of the product.

Add the Möbius loop to your artwork at no additional charge. Please be sure to specify "Print the Möbius loop" on your order. (Möbius loop imprint defaults to left-hand hand corner)

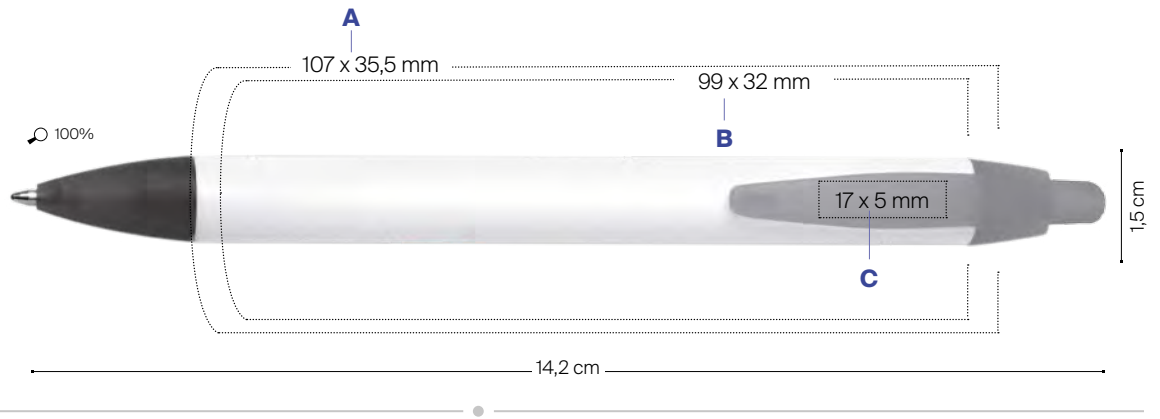

*1E81
Ballpen
Bille
Bolígrafo
Kugelschreiber
Penna a sfera

- A > DG:** full-colour (area for images)
- B > DG:** full-colour (area for text)
- C > SP:** max. 1 colour

Clip and Section
OPAQUE

FROSTED

Barrel
OPAQUE

01	02	03	40	63	66	1E
07	18	67	68	69		
	71					



MOQ: 500 u.

PMS SERVICE
≥10.000 u.

*≥ 25.000 u. for custom made Section



250
±2,6 Kg



Red ink available under request

If you want more information about our BIC® Ecolutions & how it's made
visit: bicgraphic.eu/ie/sustainable-development.html.



Wide Body™ Chrome

EN > Premium version with **chrome-coloured section**.

FR > Version premium avec des **couleurs chromées sur le côté**.

ES > Versión premium con **la sección cromada**.

DE > Premium-Version mit **chromfarbiger Spitze**.

IT > Versione premium con **puntale cromato**.

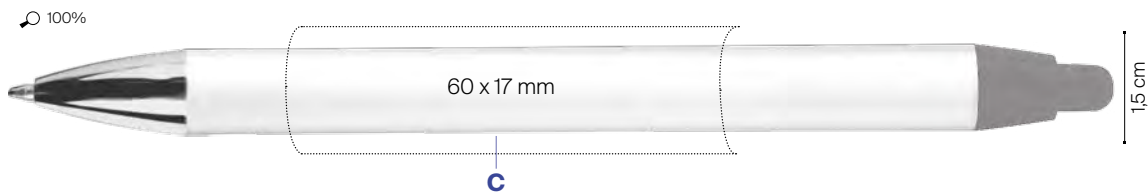

1079 Chrome

- Ballpen
- Bille
- Bolígrafo
- Kugelschreiber
- Penna a sfera

A / C > SP: max. 2 colours

B > SP: max. 1 colour

Barrel and Clip
OPAQUE



FROSTED

Section and Cover



MOQ: 250 u.

PMS SERVICE
≥ 10.000 u.



Red ink available under request





MIX & MATCH

Wide Body™ Chrome Digital

By the expert in...
In digital printing

BALLPENS

BIC® WRITING INSTRUMENTS

EN > Wide profile and the largest 360° imprint area in the market, with full-colour imprint available on all frosted and opaque barrel colours! Reinventing digital to maximize your personalisation options.

FR > Profil large avec zone de marquage à 360°, la plus large du marché, avec un marquage dans toutes les couleurs, disponible dans toutes les teintes de corps givrées et opaques! Nous réinventons le numérique pour optimiser les options de personnalisation.

ES > Perfil ancho con el área de marcado 360° más grande del mercado, con impresión a todo color disponible en todos los colores de cuerpo frosted y opacos! Reinventamos el digital para ampliar tu opciones de personalización.

DE > Breites Profil und die größte 360°-Druckfläche auf dem Markt, mit Vollfarbdruck für alle gefrosteten und opaken Schaftfarben! Die digitale Neuerung, um Ihre Personalisierungsoptionen zu maximieren.

IT > Profilo ampio con l'area di stampa a 360° più grande del mercato, con stampa multicolore in tutte le varianti frost e opache! Reinventiamo il digitale per aumentare le tue opzioni di personalizzazione.



100%

1895 Chrome
Ballpen
Bille
Bolígrafo
Kugelschreiber
Penna a sfera

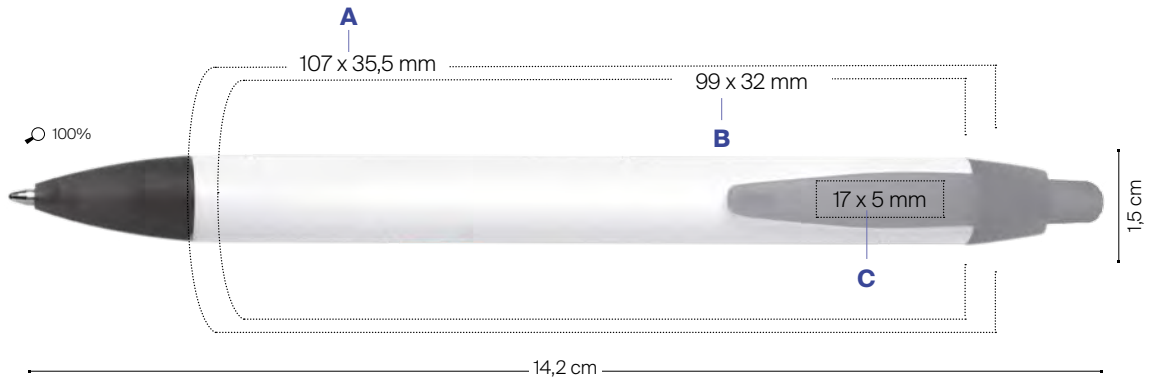

- A> DG: full-colour (area for images)
- B> DG: full-colour (area for text)
- C> SP: max. 1 colour

Barrel and Clip
OPAQUE

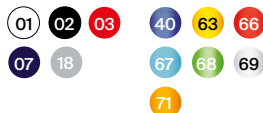

Section and Cover



MOQ: 500 u.

PMS SERVICE
≥10.000 u.

*≥25.000 u. for custom made Section



250
±2,6 Kg

MADE IN SPAIN

Red ink available under request





Wide Body™ Mini Digital

By the expert in...
In digital printing

EN > Compact version ideal to fit any pocket! Wide profile and a wide **360° full-colour imprint area!**

FR > Version compacte idéale pour s'adapter à tous les sacs ! Profil large et grandeur, il offre une **large zone d'impression à 360° dans toutes les couleurs !**

ES > ¡Versión compacta ideal para adaptarse a cualquier bolsillo! Con perfil ancho, ¡ofrece una **amplia área de impresión 360° a todo color!**

DE > Kompakte Version, die perfekt in jede Hosentasche passt! Breites Profil mit großer **360° Vollfarbdruck-Fläche!**

IT > Versione compatta ideale per tutte le tasche! Ampio profilo, offre una **grande area di stampa a 360° a colori!**

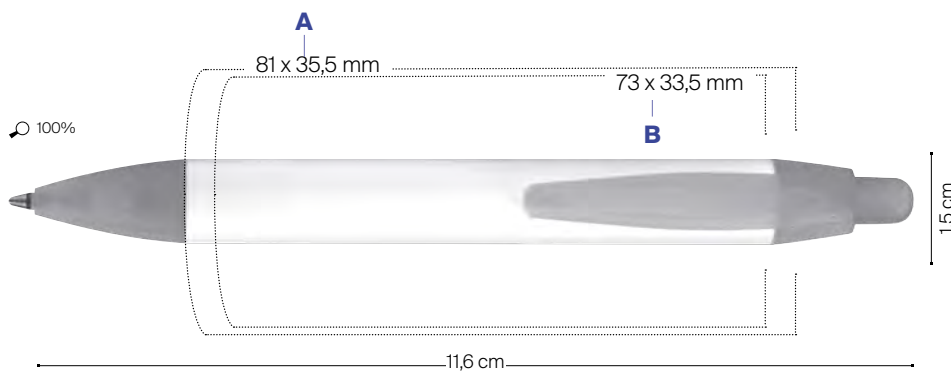

1893

Ballpen
Bille
Bolígrafo
Kugelschreiber
Penna a sfera

A> DG: full-colour
(area for images)

B> DG: full-colour
(area for text)

Barrel
OPAQUE

01

Clip, Cover and Section
OPAQUE FROSTED

01 02 03 40 63 66
07 18 67 68 69
71



MOQ: 500 u.

PMS SERVICE
≥10.000 u.

*≥ 25,000 u. for custom made Section



250
±1,9 Kg





MIX & MATCH

Wide Body™ Mini Digital Chrome

By the expert in...
In digital printing

BALLPENS

BIC® WRITING INSTRUMENTS

EN > Compact version ideal to fit any pocket! Wide profile and a wide **360° full-colour imprint area!**

FR > Version compacte idéale pour s'adapter à tous les sacs ! Profil large et grandeur, il offre une **large zone d'impression à 360° dans toutes les couleurs !**

ES > ¡Versión compacta ideal para adaptarse a cualquier bolsillo! Con perfil ancho, ¡ofrece una **amplia área de impresión 360° a todo color!**

DE > **Kompakte Version**, die perfekt in jede Hosentasche passt! Breites Profil mit großer **360° Vollfarbdruck-Fläche!**

IT > **Versione compatta** ideale per tutte le tasche! Ampio profilo, offre una **grande area di stampa a 360° a colori!**



100%

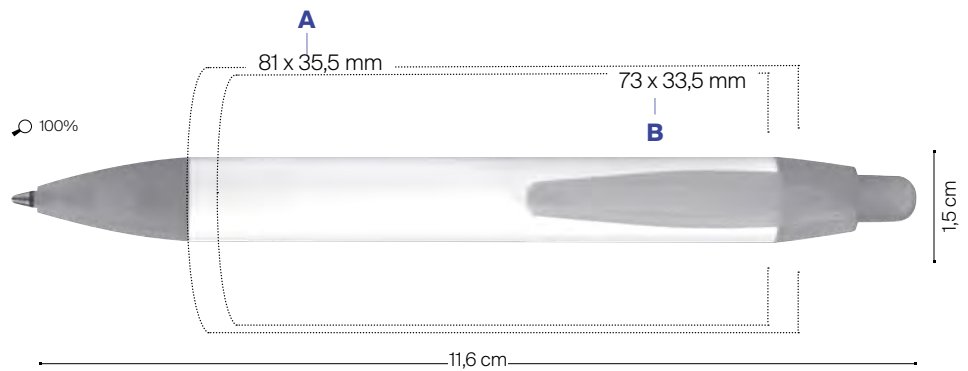

1896 Chrome

Ballpen
Bille
Bolígrafo
Kugelschreiber
Penna a sfera

A > DG: full-colour (area for images)

B > DG: full-colour (area for text)

Barrel
OPAQUE

01

Clip
OPAQUE

01 02 03
07 18

FROSTED

40 63 66
67 68 69
71

Section and Cover

35



MOQ: 500 u.

PMS SERVICE
≥10.000 u.

*≥25.000 u. for custom made Section



250
±1,9 Kg



 **Atlantis®**





Atlantis®



EN > Comfortable design with soft rubberised grip. A smooth writing experience thanks to the BIC® Easy Glide system®.

FR > Design pratique avec grip en caoutchouc doux. Expérience d'écriture fluide grâce au BIC® Easy Glide system®.

ES > Diseño cómodo con grip de goma suave. Experiencia de escritura fluida gracias al BIC® Easy Glide system®.

DE > Komfortables Design mit weicher Gummigriffzone. Geschmeidiges, weiches Schreiberlebnis dank des BIC® Easy Glide Systems®.

IT > Design pratico con impugnatura in gomma morbida. Esperienza di scrittura fluida grazie al BIC® Easy Glide system®.



BALLPENS

BIC® WRITING INSTRUMENTS

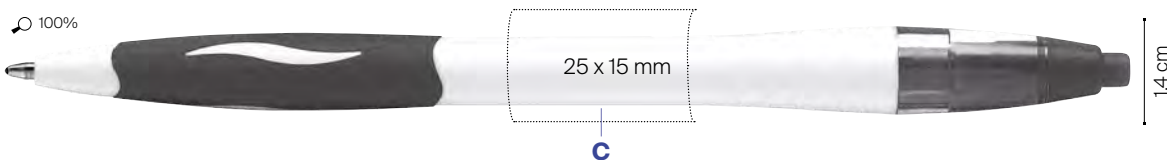
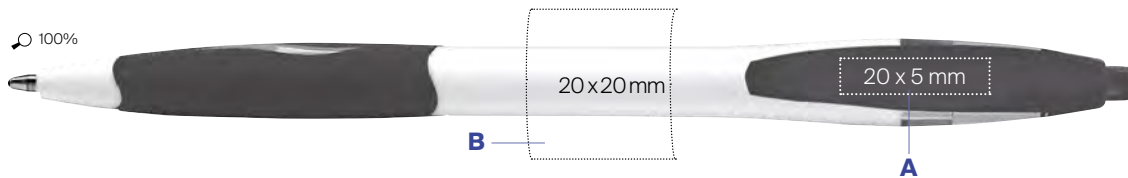

1053 / 1060 Clear

Ballpen
Bille
Bolígrafo
Kugelschreiber
Penna a sfera

A > PD: max. 1 colour

B / C > SP: max. 2 colours

1053

Barrel / Trims / Ink
OPAQUE



1060 Clear

Barrel / Trims / Ink
CLEAR / OPAQUE

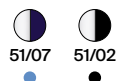

MOQ: 250 u.



± 2,3 Kg



 **Clic**  **olutions**®





Clic eColutions® & Clic Gold eColutions®



By the expert in...
Writing Instruments

BALLPENS

BIC® WRITING INSTRUMENTS

EN > A versatile design that can match any style, from classic to modern, that **adds environmental awareness to your message.**

FR > Un design multifonction qui s'adapte à tous les styles, du classique au moderne, et qui **apporte une dimension de responsabilité environnementale à votre message.**

ES > Un diseño versátil que puede adaptarse a cualquier estilo, desde el clásico al moderno, y que **añade conciencia ambiental a tu mensaje.**

DE > Vielseitiges Design, das jede Stilrichtung verkörpert - von der Klassik bis hin zur Moderne. **Umweltbewusstsein ist jetzt Teil Ihrer Botschaft.**

IT > Un design versatile che può adattarsi a qualunque stile, da quello classico a quello moderno, con **l'aggiunta di una coscienza ambientale al tuo messaggio.**

MIX & MATCH

MIX & MATCH SERVICE!

*1093 / *1092 Clear

MOQ: 5.000 units

Please ask to your Customer Service for the available colours and all the information of this service.



1091

1090

1093



- *1091 Gold /
- *1090 Gold Clear /
- *1093 /
- *1092 Clear
- Ballpen
- Bille
- Bolígrafo
- Kugelschreiber
- Penna a sfera

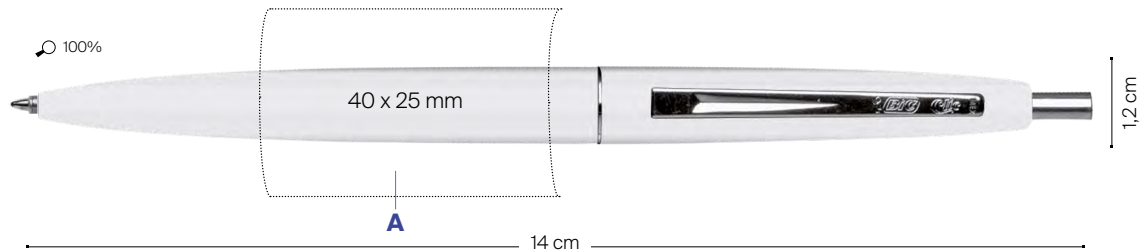

A> SP: max. 2 colours

***1091 Gold**
Barrel / Trims / Ink
OPAQUE

01/26	02/26	07/26

***1090 Gold Clear**
Barrel / Trims / Ink
CLEAR

86/26

***1093**
Barrel / Trims
OPAQUE

01/35	02/35	03/35	04/35
5C/35	59/35	07/35	12/35

***1092 Clear**
Barrel / Trims / Ink
CLEAR

88/35*	93/35*	95/35*

*While stock lasts

***1091 Gold / *1090 Gold Clear *1092 Clear**

M	M

MOQ: 250 u.

250
±2,3 Kg

If you want more information about our BIC® Ecolutions & how it's made
visit: bicgraphic.eu/ie/sustainable-development.html.





4 Colours Family

Simple, inventive, reliable. Four different ink colours in one. An icon that's always in fashion!



4 Colours

- EN >** Simple, inventive, reliable. **Four different ink colours in one:** blue, black, red, green. **An icon that's always in fashion!**
- FR >** Simple, fiable, ingénieux. **Quatre couleurs d'encre différentes sur un seul stylo-bille :** bleu, noir, rouge, vert. **Un stylo emblématique toujours à la mode !**
- ES >** Simple, ingenioso, fiable. **Cuatro colores de tinta diferentes en un sólo bolígrafo:** azul, negro, rojo, verde. **¡Un icono que siempre está de moda!**
- DE >** Einfach, zuverlässig, einfallsreich. **Vier verschiedene Tintenfarben in einem Kugelschreiber:** Blau, Schwarz, Rot und Grün! **Eine Schreibikone, die immer in Mode bleibt.**
- IT >** Semplice, ingegnosa, affidabile. **Quattro diversi colori in una sola penna:** blu, nero, rosso e verde. **Un'icona intramontabile!**



1100

100%

1100 / 1101 Lanyard
Ballpen
Bille
Bolígrafo
Kugelschreiber
Penna a sfera

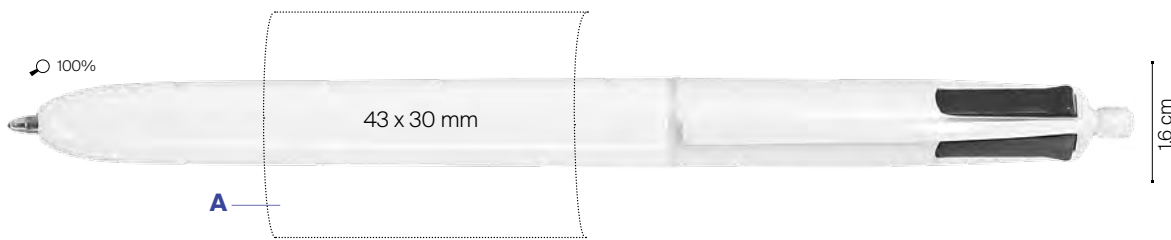

A > SP: max. 4 colours

14,4 cm

1100 / 1101 Lanyard
Cap and Barrel
OPAQUE

01/01 02/02 01/07



1101

MOQ: 250 u.



1100

1101

250
± 3,2 Kg

300
± 6 Kg



* Only for 1100



4 Colours Mini

EN > Four different ink colours in one!
Even more functional in a **reduced size**.

FR > Quatre couleurs d'écriture dans un stylo ! Plus fonctionnel maintenant grâce à sa **taille réduite**.

ES > ¡4 colores de tinta diferentes en un producto! Todavía más práctico con un **tamaño reducido**.

DE > Vier verschiedene Tintenfarben in einem Schreibgerät.
Noch funktioneller in **reduzierter Größe**.

IT > Quattro colori di inchiostro differenti in un unico prodotto! Ancora più funzionale grazie alle sue **ridotte dimensioni**.



1103

1103 / 1104 Lanyard
Ballpen
Bille
Bolígrafo
Kugelschreiber
Penna a sfera

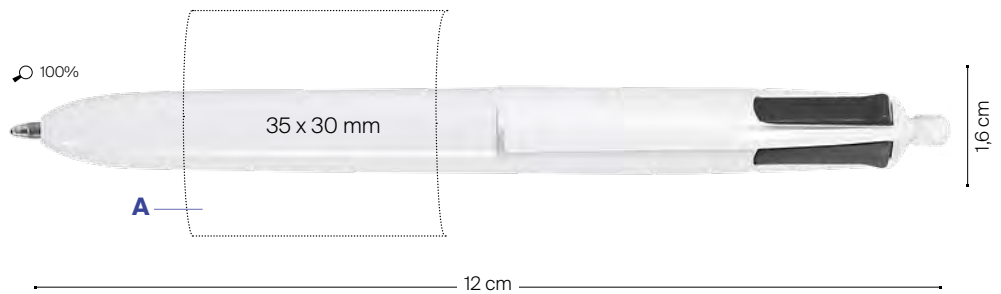

A > SP: max. 4 colours

1103 / 1104 Lanyard

Cap and Barrel
OPAQUE

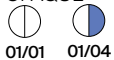

1104

MOQ: 250 u.



* Only for 1103



1103

250

± 2.7 Kg

1104

300

± 5.5 Kg





4 Colours Fashion

EN > The trendy version of our iconic ballpen features 4 fashion ink colours: **ultramarine blue, deep purple, acid green and pink.**

FR > La version moderne de notre stylo-bille le plus emblématique se décline en quatre couleurs actuelles : **turquoise, violet profond, vert acide et rose bonbon.**

ES > La versión moderna de nuestro bolígrafo más icónico en 4 colores de tinta actuales: **azul ultramarino, púrpura oscuro, verde ácido y rosa chicle.**

DE > Die trendige Version unserer Kugelschreiber-Ikone mit 4 modischen Tintenfarben: **Ultramarinblau, Dunkelblau, Acidgrün und Pink.**

IT > La versione aggiornata della nostra penna più classica in 4 moderni colori di scrittura: **blu oltremare, porpora scuro, verde acido e fucsia.**



1102 / 1108 Lanyard
Ballpen
Bille
Bolígrafo
Kugelschreiber
Penna a sfera

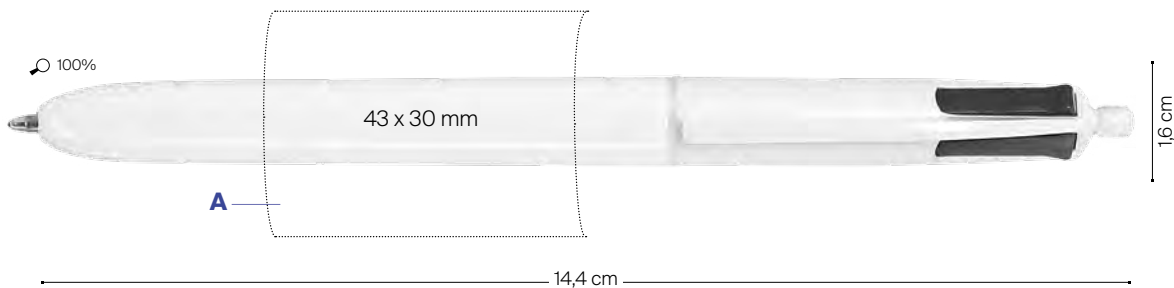

A > SP: max. 4 colours

1102 / 1108 Lanyard
Cap and Barrel
OPAQUE



MOQ: 250 u.



* Only for 1102

1102 250 ± 3.2 Kg
1108 300 ± 6 Kg





4 Colours Sun



EN > 4 fashion colours in one pen, include 2 new colours: **orange & yellow with a sunny barrel.**

FR > 4 couleurs tendance dans un stylo, avec 2 nouvelles couleurs : **orange et jaune avec un corps aux couleurs vives.**

ES > 4 colores actuales en un mismo bolígrafo; incluye 2 colores de tinta nuevos: **naranja y amarillo, en un cuerpo de un color de lo más veraniego.**

DE > 4 modische Farben in einem Schreibgerät, inklusive 2 neuer Farben: **Orange und Gelb mit einem sonnigen Schaft.**

IT > 4 colori fashion in una penna, include 2 nuovi colori: **arancione e giallo in un fusto solare.**



100%

1097 / 1098 Lanyard
Ballpen
Bille
Bolígrafo
Kugelschreiber
Penna a sfera

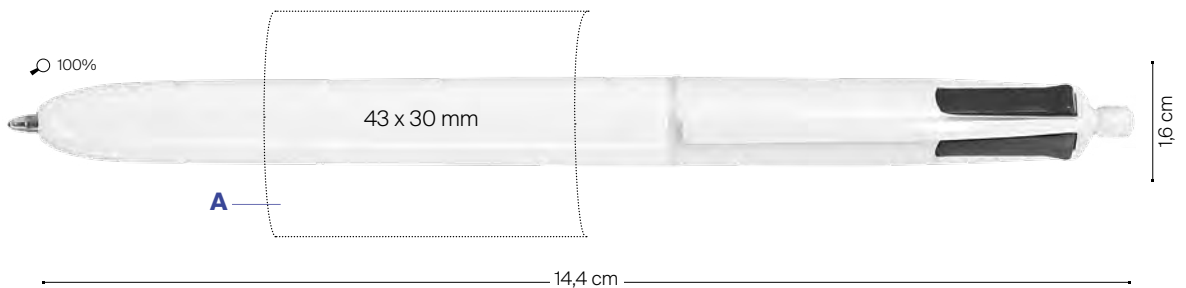

A > SP: max. 4 colours

1097 / 1098 Lanyard
Cap and Barrel
OPAQUE
01/12



1098

MOQ: 250 u.



1097

250
± 3,2 Kg

1098

300
± 6 Kg



BALLPENS

BIC® WRITING INSTRUMENTS



4 Colours Shine

EN > The iconic BIC® 4 Colours presented in **shiny metallic colours**. It features 4 standard colour inks: **blue, black, red and green**.

FR > Le célèbre BIC® 4 Colours, icône de la marque, présenté dans des **couleurs métallisées brillantes**. Disponible dans 4 couleurs d'encre standard : **bleu, noir, rouge et vert**.

ES > El icónico BIC® 4 Colours presentado en **colores metálicos brillantes**. Cuenta con 4 colores de tinta estándar: **azul, negro, rojo y verde**.

DE > Der ikonische BIC® 4 Colours in **glänzenden Metallic-Farben**. Enthält vier Standard-Farbtinten: **Blau, Schwarz, Rot und Grün**.

IT > L'iconica BIC® 4 Colours in **brillanti colori metallici**. Ha 4 colori di inchiostro standard: **blu, nero, rosso e verde**.



1106

1106

100%

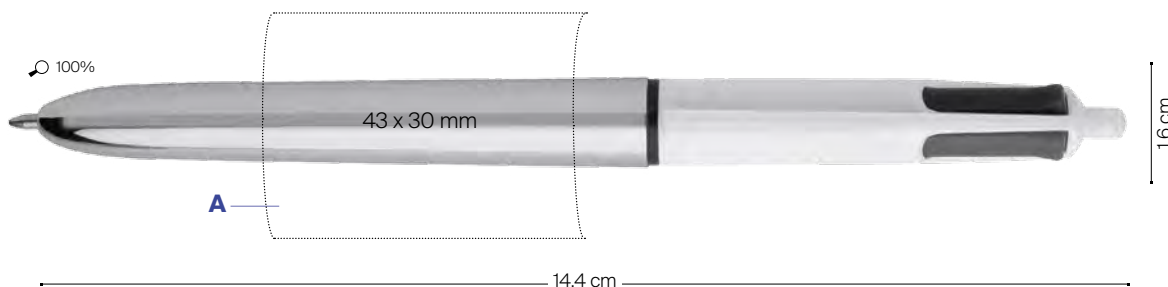

1106 / 1107 Lanyard
Ballpen
Bille
Bolígrafo
Kugelschreiber
Penna a sfera

A > SP: max. 2 colours

1106 / 1107 Lanyard
Cap and Barrel
OPAQUE



MOQ: 250 u.



1106

250
± 3,2 Kg

1107

300
± 6 Kg





4 Colours Fine

- EN >** Colourful fine line version. It features 4 standard colour inks: **blue, black, red and green.**
- FR >** Sa version colorée avec un tracé fin. Elle offre 4 couleurs d'encre standard : **bleu, noir, rouge et vert.**
- ES >** La versión más atrevida con una escritura fina. Cuenta con 4 tintas de color estándar: **azul, negro, rojo y verde.**
- DE >** Farbenfrohe Version mit feiner Strichstärke. In vier Standard-Tintenfarben erhältlich: **Blau, Schwarz, Rot und Grün.**
- IT >** La versione colorata con scrittura sottile. Dispone di 4 colori di inchiostro: **blu, nero, rosso e verde.**



1109

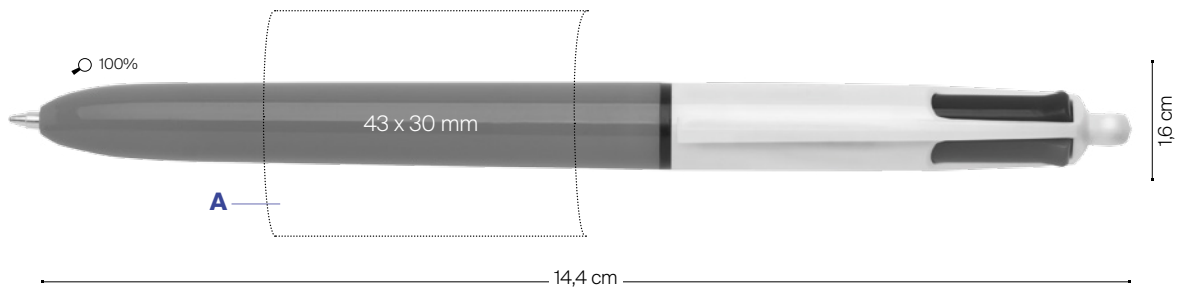

1109 / 1111 Lanyard
Ballpen
Bille
Bolígrafo
Kugelschreiber
Penna a sfera

A > SP: max. 4 colours

1109 / 1111 Lanyard
Cap and Barrel
OPAQUE
01/10



1111

MOQ: 250 u.



* Only for 1109

1109



± 3,2 Kg

1111



± 6 Kg





4 Colours *britePix*™ & 4 Colours Fashion

britePix™

- EN >** The icon with full-colour imprint available on the barrel.
- FR >** L'icône, avec une impression full-color sur le corps.
- ES >** El icono, con impresión a todo color disponible en el cuerpo.
- DE >** Die Ikone mit Vollfarbdruck auf dem Schaft.
- IT >** La nostra icona, con stampa full-colour sul corpo.



1113



1115

- 1113 *britePix*™ /
- 1117 *britePix*™ Lanyard /
- 1115 Fashion *britePix*™ /
- 1118 Fashion *britePix*™ Lanyard
- Ballpen
- Bille
- Bolígrafo
- Kugelschreiber
- Penna a sfera

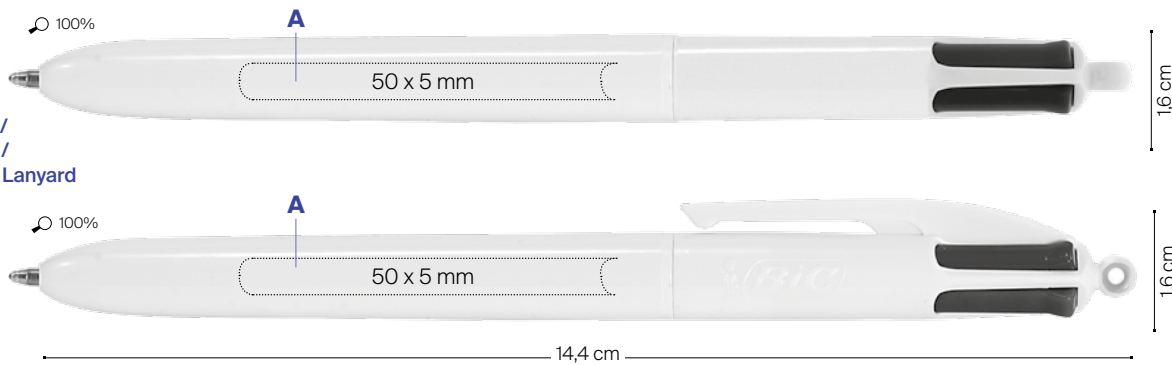

A > BP: full-colour

- 1113 *britePix*™ / 1117 *britePix*™ Lanyard /
- 1115 Fashion *britePix*™ / 1118 Fashion *britePix*™ Lanyard
- Cap and Barrel
- OPAQUE



01/01



1118



MOQ: 250 u.



* Only for 1113/1115

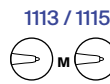

±3.2 Kg

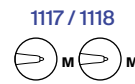

±6 Kg





4 Colours Fluo

- EN >** 3 standard ink colours, blue, black and red, **combined with a smooth bright yellow ink highlighter.**
- FR >** Trois encres de couleurs standards (bleu, noir et rouge), **combinées avec un surligneur fin d'une couleur jaune brillante.**
- ES >** Tres colores estándar de tinta (azul, negro y rojo), **combinados con un marcador fino de color amarillo brillante.**
- DE >** Drei Standard-Tintenfarben - Blau, Schwarz und Rot - **kombiniert mit einem softem, leuchtend gelbem Tinten-Highlighter.**
- IT >** Tre colori con inchiostro standard (blu, nero e rosso), **combinati con un evidenziatore sottile di colore giallo brillante.**



1114



1114 / 1116 Lanyard
Ballpen
Bille
Bolígrafo
Kugelschreiber
Penna a sfera

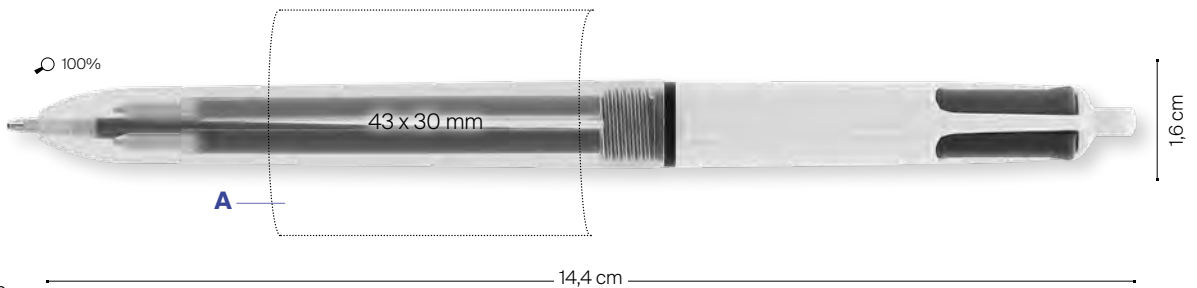

A > SP: max. 4 colours

1114 / 1116 Lanyard
Cap and Barrel
OPAQUE/CLEAR
01/4D



1116

MOQ: 250 u.



* Only for 1114

1114
250
± 3,2 Kg

1116
300
± 6 Kg



BALLPENS

BIC® WRITING INSTRUMENTS



4 Colours Stylus

EN > Simple, inventive, reliable, and now also Stylus! **An authentic 5 in 1 with stylus on top and four standard ink colours:** blue, black, red, green.

FR > Simple, fiable et original, aujourd'hui également disponible en Stylus ! **Un véritable stylo 5 en 1 avec un stylet au niveau de la pointe et quatre couleurs d'encre standard :** bleu, noir, rouge et vert.

ES > ¡Simple, original y fiable y ahora además Stylus! **Un auténtico 5 en 1 con un stylus en la parte superior y cuatro tintas de colores estándar:** azul, negro, rojo y verde.

DE > Einfach, einfallsreich, zuverlässig und jetzt auch noch mit Stylus! Ein **authentischer 5-in-1 mit Stylus an der Spitze und vier Standard-Tintenfarben:** Blau, Schwarz, Rot und Grün.

IT > Semplice, originale, affidabile e ora anche Stylus! **Un autentico 5 in 1 con stylus sulla punta superiore e quattro colori di scrittura:** blu, nero, rosso e verde.



100%

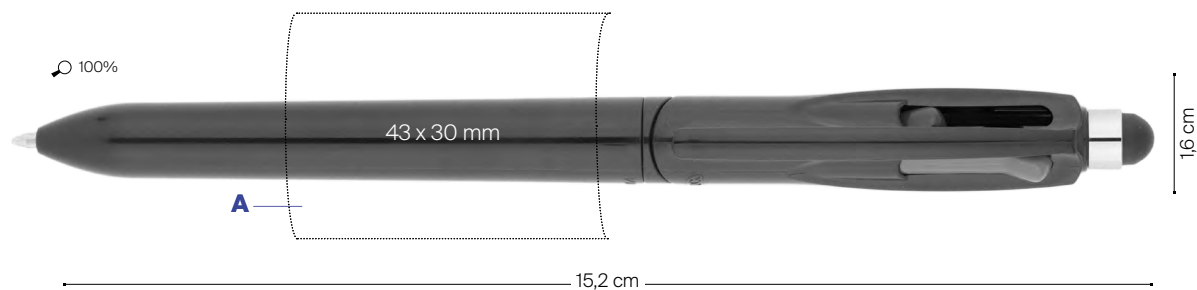

1112
Ballpen
Bille
Bolígrafo
Kugelschreiber
Penna a sfera

A > SP: max. 4 colours

Cap and Barrel
OPAQUE

02/02

MOQ: 250 u.



250
±3,8 Kg





4 Colours 3+1^{HB}



EN > 3 ballpens and 1 mechanical pencil in one! Choose whether writing in black, blue or red ink; or switch to the pencil option. Featuring a comfortable cushioned grip.

FR > 3 stylos à bille combinés avec 1 portemine ! Sélectionnez une des trois couleurs (noir, bleu ou rouge), ou utilisez l'option portemine. Avec une zone de préhension confortable.

ES > ¡3 bolígrafos y un lápiz de minas en uno! Podrás elegir entre escribir con tinta negra, roja o azul o utilizar la opción lápiz.

DE > 3 Kugelschreiber und ein Feinminstift in einem! Wählen Sie aus, ob Sie mit schwarzer, blauer oder roter Tinte schreiben oder den Feinminstift nutzen möchten. Mit Komfort-Griffzone.

IT > 3 penne a sfera e 1 portamina in uno! Scegli se scrivere con inchiostro nero, blu o rosso o se passare alla funzione matita. Comoda impugnatura imbottita.



BALLPENS

BIC® WRITING INSTRUMENTS

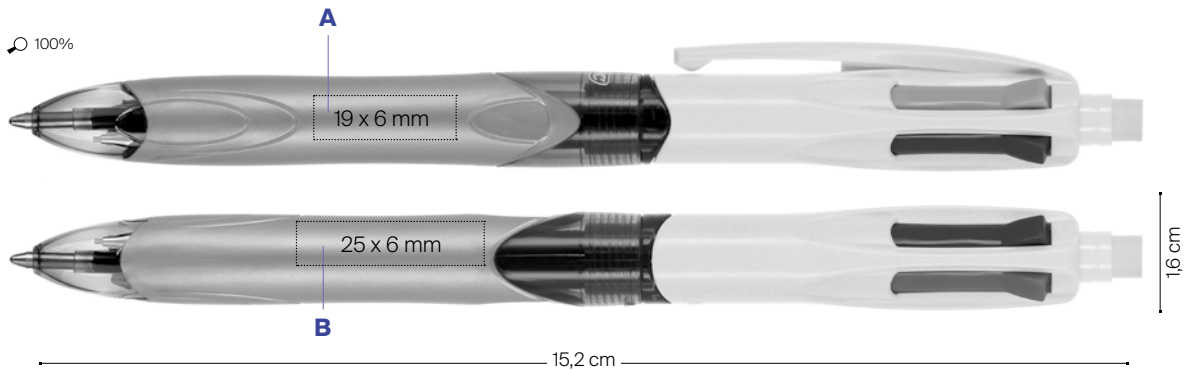

1099
Ballpen
Bille
Bolígrafo
Kugelschreiber
Penna a sfera

A > LE
B > LE

Cap and Barrel
OPAQUE



MOQ: 250 u.







Citation

Elegant classic pen with slim profile.



Citation

- EN** > Elegant classic pen with slim profile.
- FR** > Élégant stylo classique au profil mince.
- ES** > Elegante bolígrafo de perfil esbelto.
- DE** > Eleganter, klassischer Kugelschreiber mit schlankem Profil.
- IT** > Elegante penna classica dal profilo sottile.

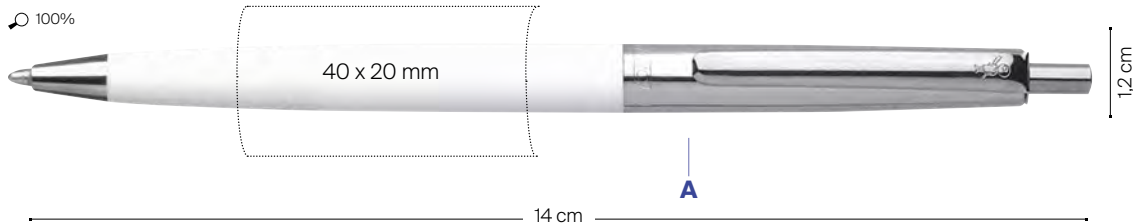

1620
Ballpen
Bille
Bolígrafo
Kugelschreiber
Penna a sfera

A> SP: max. 2 colours

Barrel
OPAQUE
01 02 07

MOQ: 50 u. ±1.3 Kg



Slim Metal

EN > Curved clip design.
Metallic finish.

FR > Clip au design incurvé.
Fini métallisé.

ES > Diseño curvado del clip.
Acabado metálico.

DE > Gebogenes Clip-Design.
Metallic-Finish.

IT > Design con clip curva.
Finitura metallizzata.



METALLIC PENS

BIC® WRITING INSTRUMENTS



A



B

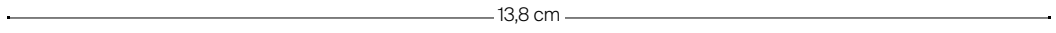

1942
Ballpen
Bille
Bolígrafo
Kugelschreiber
Penna a sfera

A > LE
B > SP: max. 1 colour

Cap / Ink
OPAQUE



While stock lasts



MOQ: 50 u.



* Only available in LE



150
± 3,65 Kg

Standard Packaging: Black velvet pouch for 1 item
Optional Packaging: (pg 276)



Rondo Evo & Rondo Evo Soft



- EN >** The BIC® Rondo Evo is a true evolution: **all-metal barrel, metallic ink refill and a wide range of colours!**
- FR >** Le BIC® Rondo Evo est un véritable produit évolutif avec : **un corps entièrement métallique, une recharge d'encre métallique et une vaste gamme de couleurs !**
- ES >** ¡El BIC® Rondo Evo es un verdadero producto evolutivo: **cuerpo totalmente metálico, recambio de tinta metálico y una amplia gama de colores!**
- DE >** Der BIC® Rondo Evo ist eine echte Evolution: **Vollmetall-Schaft, Metall-Nachfüllmine und eine breite Farbauswahl!**
- IT >** La BIC® Rondo Evo è un prodotto davvero innovativo: **corpo completamente metallico, refill in metallo e una vasta gamma di colori!**



1278* / 1272 (Soft)*

- Ballpen
- Bille
- Bolígrafo
- Kugelschreiber
- Penna a sfera

1279* / 1273 (Soft)*

- Mechanical pencil
- Porte-mine
- Portaminas
- Druckbleistift
- Portamine

A > SP: max. 2 colours

B/C > LE: right, left, barrel rear and clip centered

1272 / 1273

A/B/C > LE: right, left, barrel rear and clip centered

1278 / 1279

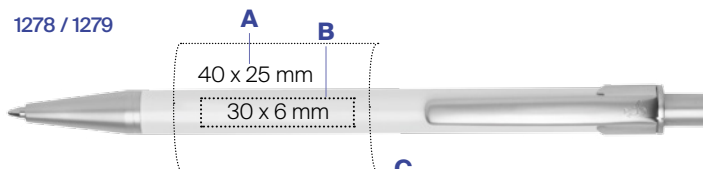

1272 / 1273

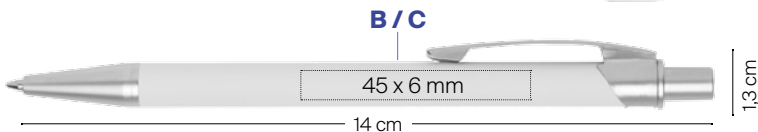
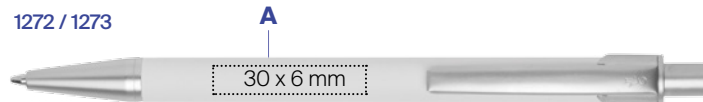

Cap / Barrel / Ink
OPAQUE



MOQ: 50 u.



Standard Packaging: Black velvet pouch for 1 item
Optional Packaging: (pg 276)

*While stock lasts



Attriant®

- EN >** Polished finish with chrome-coloured trim.
- FR >** Finition polie avec attributs de couleur chromée.
- ES >** Acabado pulido con atributos de color cromado.
- DE >** Polierte Oberfläche mit chromfarbigen Applikationen.
- IT >** Finitura lucida con particolari color cromo.



METALLIC PENS

BIC® WRITING INSTRUMENTS

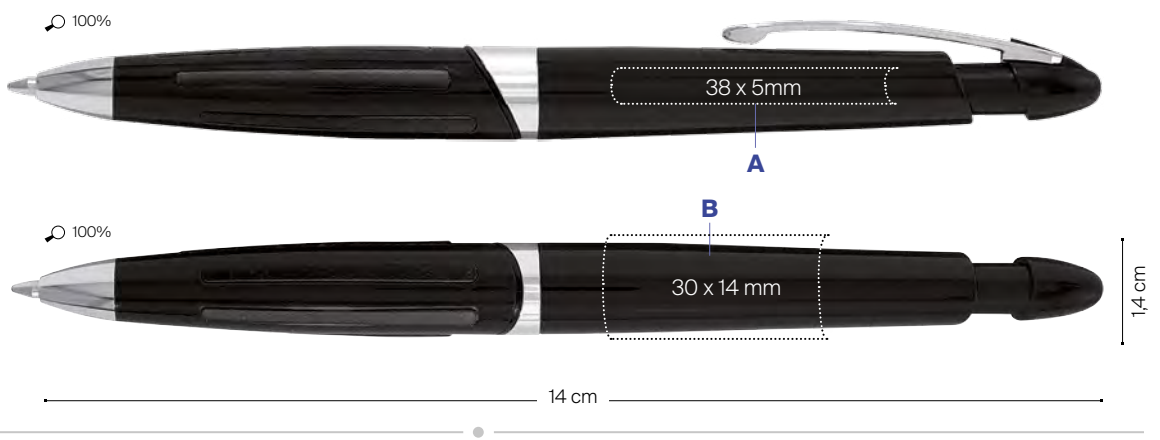

1840
Ballpen
Bille
Bolígrafo
Kugelschreiber
Penna a sfera

A> LE: right & left clip
B> SP: max. 1 colour

Barrel / Ink

02 50



MOQ: 50 u.

48h

M

150

± 4,65 Kg

Standard Packaging: Black velvet pouch for 1 item
Optional Packaging: (pg 276)



Wide Body™ Metal Grip

- EN >** Wide-profile, **all metal construction** with satin chrome plated trim.
- FR >** Profil large, **entièrement fabriqué en métal** avec des détails chromés satinés.
- ES >** Perfil ancho, **todo fabricado de metal** con atributos cromados satinados.
- DE >** Breites Profil, **Metallkorpus** mit satinierten Chromelementen.
- IT >** Profilo ampio, **completamente in metallo** con rifiniture cromate satinata.

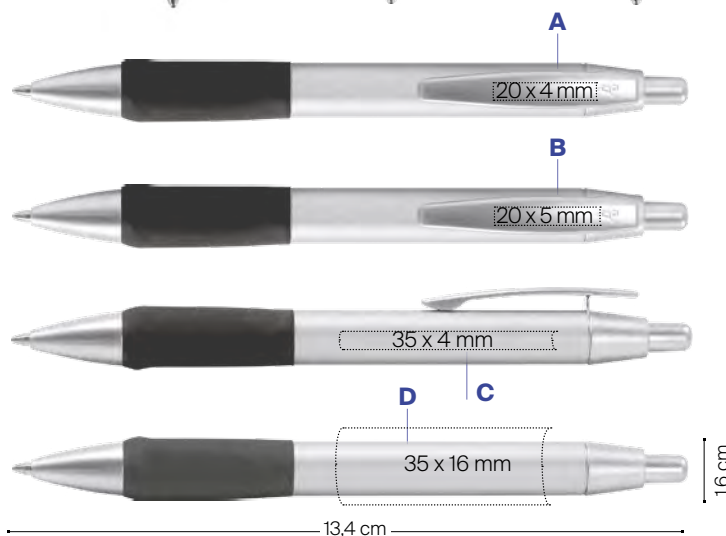

1286

Ballpen
Bille
Bolígrafo
Kugelschreiber
Penna a sfera

A / B > LE

C > LE: right, left & rear clip

B / D > SP: max. 1 colour

Grip/ Ink



While stock lasts



MOQ: 50 u.



* Only available in LE



± 45 Kg

Standard Packaging: Black velvet pouch for 1 item
Optional Packaging: (pg 276)



Wide Body™ Metal

EN > Wide-profile, **all metal construction** with satin chrome plated trim.

FR > Profil large, **entièrement fabriqué en métal** avec des détails chromés satinés.

ES > Perfil ancho, **todo fabricado de metal** con atributos cromados satinados.

DE > Breites Profil, **Metallkorp** mit satinierten Chromelementen.

IT > Profilo ampio, **completamente in metallo** con rifiniture cromate satinata.



METALLIC PENS

BIC® WRITING INSTRUMENTS

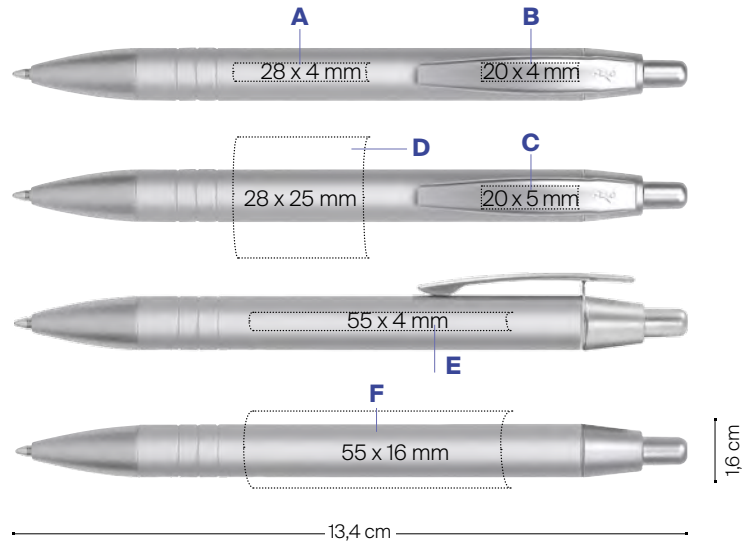

- 1285 Ballpen
- Bille
- Bolígrafo
- Kugelschreiber
- Penna a sfera

A / B > LE
E > LE: right, left & rear clip
C / D / F > SP: max. 1 colour



MOQ: 50 u.

* Only available in LE

Standard Packaging: Black velvet pouch for 1 item
 Optional Packaging: (pg 276)



Protrusion Grip

- EN >** Comfortable soft grip with polished **chrome plated steel clip**.
- FR >** Grip en relief au toucher doux avec **clip en acier chromé poli**.
- ES >** Suave grip en relieve con **clip y atributos de acero bañados en cromo**.
- DE >** Komfortable, softe Griffzone mit **poliertem, verchromtem Stahlclip**.
- IT >** Impugnatura morbida e confortevole con **clip in acciaio cromato**.

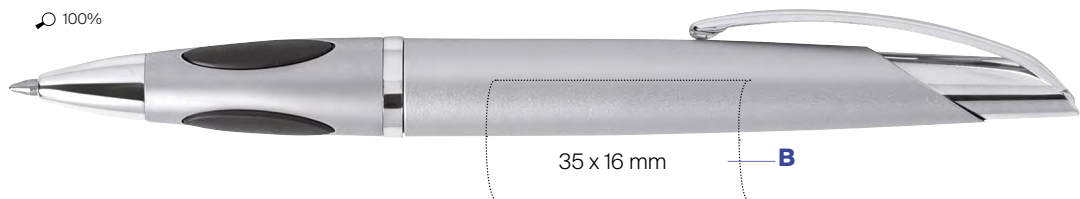
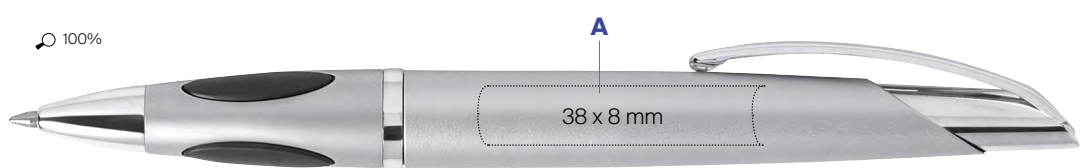

1836
Ballpen
Bille
Bolígrafo
Kugelschreiber
Penna a sfera

A> LE: right & left clip
B> SP: max. 1 colour

Barrel / Ink

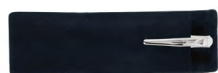

MOQ: 50 u.



* Only available in LE

± 4,65 Kg

Standard Packaging: Black velvet pouch for 1 item
Optional Packaging: (pg 276)



Tri-Tone Twist

- EN >** Satin chrome and nickel-plated trim.
- FR >** Attributs en **chrome satiné** et nickel.
- ES >** Atributos **cromado satinados** y plateado niquelados.
- DE >** Komponenten aus **satiniertem Chrom** und vernickelte Elemente.
- IT >** Finiture **cromo satinato** e nickel.



METALLIC PENS

BIC® WRITING INSTRUMENTS

1943
Ballpen
Bille
Bolígrafo
Kugelschreiber
Penna a sfera

- A >** LE: right, left & rear clip
- B >** LE*: right, left, rear & clip centred
- C >** SP: max. 1 colour

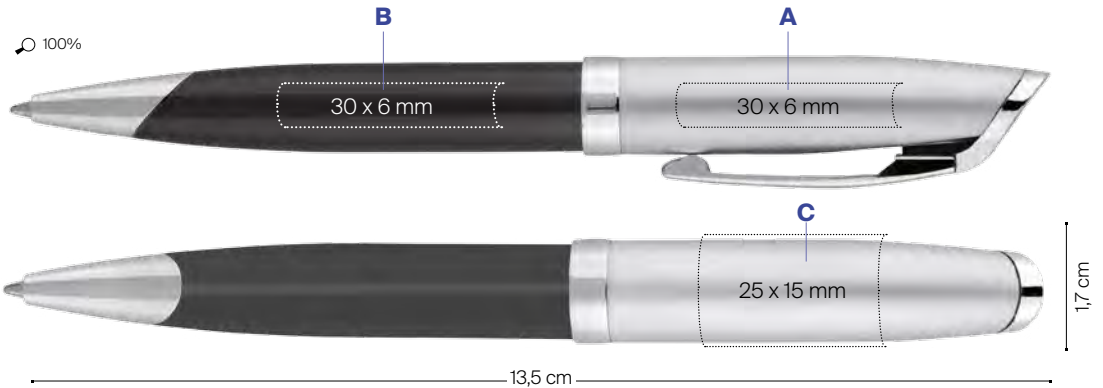

Barrel / Ink
LACQUER FINISH



* LE not available on blue barrel



MOQ: 50 u.



* Only available in LE



± 4.65 Kg

Standard Packaging: Black velvet pouch for 1 item
Optional Packaging: (pg 276)

 **Triumph 537R**





Atlantis® Gel

EN > Atlantis® family welcomes the **ultra-smooth gel ink** version dressed in a modern look with metal clip and chrome painted trim.

FR > La famille de produits Atlantis® accueille une version encre **gel ultra-douce** à l'aspect moderne, dotée d'un clip métallique et d'attributs chromés.

ES > La familia Atlantis® da la bienvenida a la versión **gel ultra suave**, con un look más moderno gracias al clip metálico y los atributos de color cromado.

DE > Die Atlantis®-Familie heißt die neue **ultraweiche Geltinten-Version** willkommen, die im modernen Look mit Metallclip und chromfarbigen Verzierungen auftritt.

IT > La famiglia Atlantis® dà il benvenuto alla versione con inchiostro **gel super scorrevole**, dal look moderno con clip in metallo e finiture cromate.



ROLLERS & GELS

BIC® WRITING INSTRUMENTS

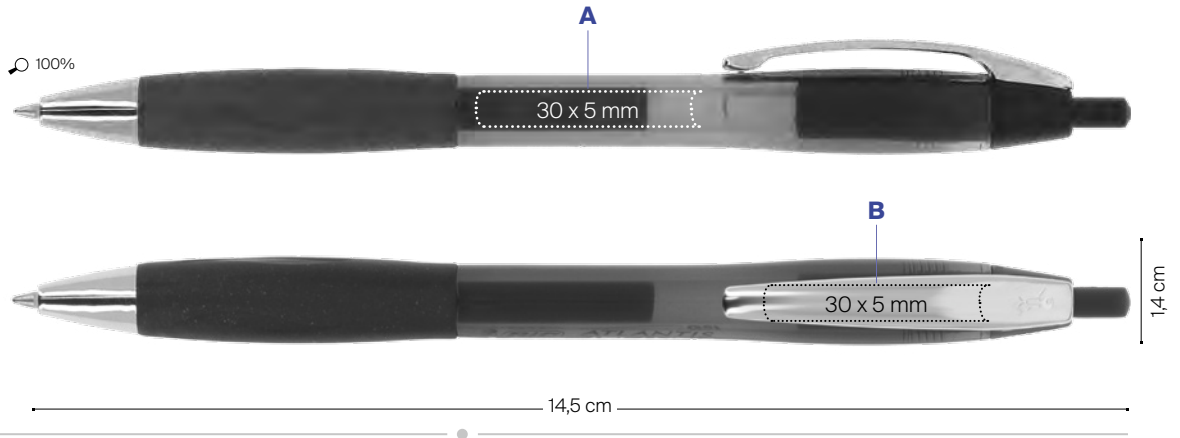

1062
Gel
Gel
Gel
Gelschreiber
Gel

A > PD: right, left
or rear clip max 1 colour
B > LE

Barrel / Ink



MOQ: 250 u.



250
± 3 Kg



Triumph 537R

EN > Water based ink for smooth writing experience. Cap off time more than 2 hours. Translucid colour barrel for ink level visibility.

FR > Encre à base d'eau pour un plus grand confort d'écriture. Le capuchon peut être retiré pendant plus de 2 heures. Corps de couleur translucide permettant de voir le niveau d'encre.

ES > Tinta a base de agua para una experiencia de escritura suave. Se puede tener destapado durante más de 2 horas. Cuerpo translúcido para poder ver el nivel de tinta.

DE > Wasserbasierte Tinte für softes Schreiberlebnis. Über 2 Stunden Cap-off-Zeit. Transluzenter, farbiger Schaft für sichtbaren Tintenstand.

IT > Inchiostro a base di acqua per un'esperienza di scrittura scorrevole. Può restare più di 2 ore senza cappuccio. Serbatoio colorato trasparente per verificare il livello dell'inchiostro.



Iconic BIC® Boy is embossed

100%

1197
Roller Ball
Stylo roller
Roller
Rollerball
Roller



A> SP: max. 1 colour

13,9 cm

Barrel / Ink
OPAQUE



MOQ: 250 u.



400
±2.6 Kg



Intensity[®] Gel Clic

- EN >** Stylish ultra-smooth gel pen available in blue and black ink. **Automatic retracting mechanism to avoid stains on the pockets.**
- FR >** Stylo-bille gel ultra doux, disponible avec une encre bleue ou noire. **Mécanisme de rétraction automatique pour éviter les tâches sur les poches.**
- ES >** Bolígrafo de gel ultra suave disponible en tinta azul y negro. **Mecanismo automático retráctil para evitar manchas en los bolsillos.**
- DE >** Stylishes, ultraweiches Gelschreibgerät mit blauer oder schwarzer Tinte. **Automatische Rückzugmechanik, um Verschmutzungen in der Tasche zu verhindern.**
- IT >** Penna gel ultra morbida disponibile in scrittura blu e nero. **Meccanismo automatico di chiusura per evitare macchie nelle tasche.**

By the expert in...
Writing Instruments



ROLLERS & GELS

BIC® WRITING INSTRUMENTS

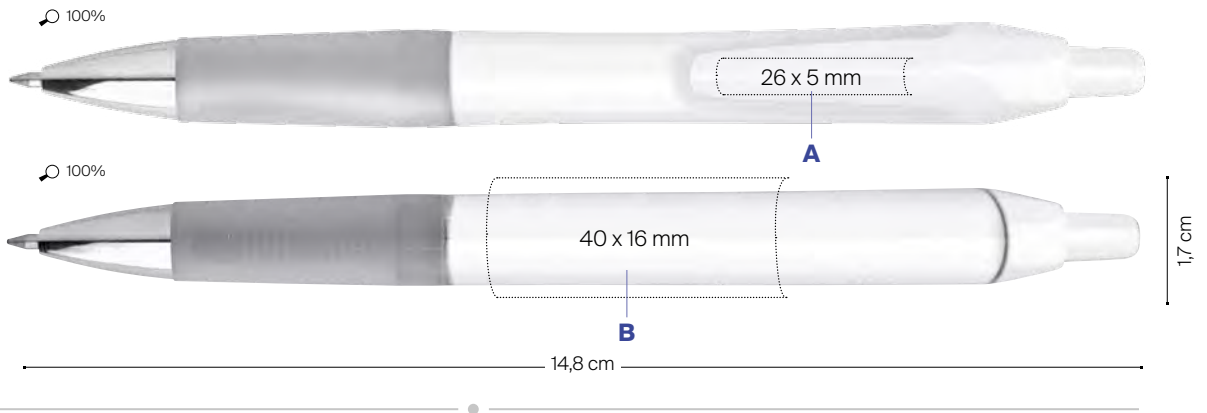

1196
Gel
Gel
Gel
Gelschreiber
Gel

A > SP: max. 2 colours
B > SP: max. 4 colours

Barrel
CLEAR



OPAQUE



MOQ: 250 u.



250
± 3,7 Kg

 **Bic® Grip Roller**





Grip Roller

By the expert in...
Writing Instruments

ROLLERS & GELS

BIC® WRITING INSTRUMENTS

- EN >** Enjoy a **smooth writing experience**. Glide across the paper easily without smudging thanks to the **quick-drying ink, ideal for both left and right-handed people**.
- FR >** Profitez d'une **expérience d'écriture fluide**. Parfait pour les droitiers comme pour les gauchers, il glisse facilement sur le papier et ne fait pas de tâches **grâce à son encre à séchage rapide**.
- ES >** Disfruta de una **experiencia de escritura suave**. Se desliza fácilmente a través del papel y sin manchas gracias a la tinta de **secado rápido, ideal tanto para las personas zurdas como diestras**.
- DE >** Genießen Sie **das weiche Schreibgefühl**. Gleiten Sie über das Papier ohne dass etwas verschmieren kann, dank der schnell trocknenden **Tinte - ideal für Links- und Rechtshänder**.
- IT >** Goditi un'**esperienza di scrittura morbidissima**. Scorre facilmente sulla carta senza macchiare grazie **all'inchiostro ad asciugatura immediata, ideale per mancini e destrorsi**.



1195

1187

100%

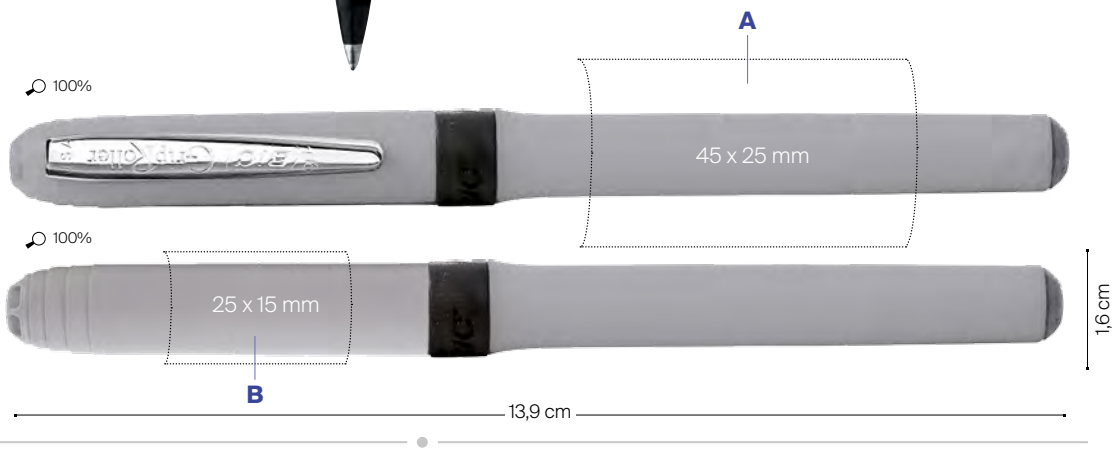

1187 / 1195 Gold
Roller Ball
Stylo roller
Roller
Rollerball
Roller

A / B > SP: max. 3 colours

- 1187**
Barrel and Cap / Clip / Ink
OPAQUE
- 01/35
 - 02/35
 - 03/35
 - 06/35
 - 07/35
 - 24/35
 - 27/35

- 1195 Gold**
Barrel and Cap / Clip / Ink
OPAQUE
- 02/26

MOQ: 250 u.

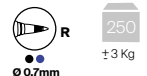

 **BIC** XS Finestyle





XS Finestyle & britePix™

- EN >** Super-smooth roller with Finestyle ink point. **Exclusive britePix™ full-colour printing on the clip also available.**
- FR >** Roller super doux avec pointe feutre fine. **Disponible aussi en version britePix™ toutes couleurs sur le clip.**
- ES >** Roller súper fluido con punta Finestyle. **También disponible con britePix™ en el clip.**
- DE >** Extrem sanft gleitender Rollerball mit Finestyle-Spitze. **Auch mit britePix™-Vollfarbdruck auf dem Clip.**
- IT >** Roller a scrittura ultra-fluida con punta Finestyle. **Disponibile anche con stampa multicolour britePix™ sulla clip.**



By the expert in...
Writing Instruments



Iconic BIC® Boy is embossed

ROLLERS & GELS

BIC® WRITING INSTRUMENTS

1851 / 1856 Clear



1852 britePix™ / 1857 Clear britePix™

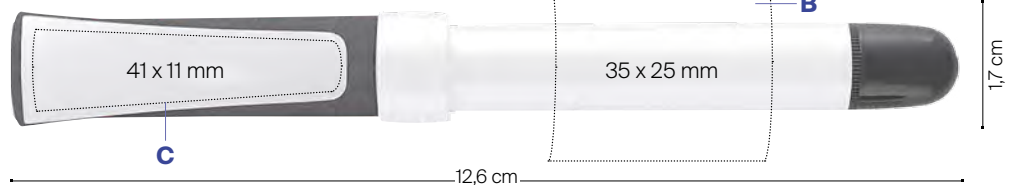

1851 /
1856 Clear /
1852 britePix™ /
1857 Clear britePix™
Finestyle

A> PD: max. 2 colours
B> SP: max. 2 colours
C> BP: full-colour

1851 / 1852

Barrel and Clip / Trims / Ink
OPAQUE

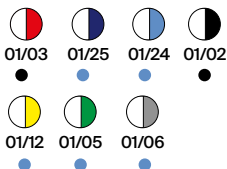

1856 / 1857 Clear

Clip, Barrel and Trims / Ink
OPAQUE / CLEAR



MOQ: 250 u.
PMS SERVICE
≥ 10,000 u.



* Only 1851 & 1856

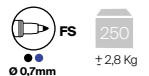

± 2,8 Kg





Highlighters & Markers



White Board Marker Fine

- EN >** Fine tip erasable marker ideal for use on dry erase boards, glass and most non-porous surfaces. **Easily erases with a dry cloth, tissue or felt eraser!**
- FR >** Feutre effaçable à pointe fine, idéal pour écrire sur les tableaux effaçables à sec, sur le verre et sur la plupart des surfaces non poreuses. **Facile à effacer avec un chiffon sec ou une brosse en feutre ou en tissu !**
- ES >** Marcador fino que se borra, ideal para pizarras de borrado en seco, vidrio y la mayoría de superficies no porosas. **¡Fácil borrado con un paño seco, borrador de fieltro o de tejido!**
- DE >** Löscharer Marker mit feiner Spitze für Whiteboards, Glas und die meisten porenfreien Oberflächen. **Leicht löschar mit trockenem Textil, Tissuetuch oder Vlies-Tafelwischer!**
- IT >** Pennarello cancellabile a punta fine ideale per lavagne cancellabili, vetro e quasi tutte le superfici non porose. **Facilmente cancellabile con un panno asciutto, un fazzoletto o un cancellino!**



1651
Marker
Marqueur
Marcador
Permanent Marker
Pennarello

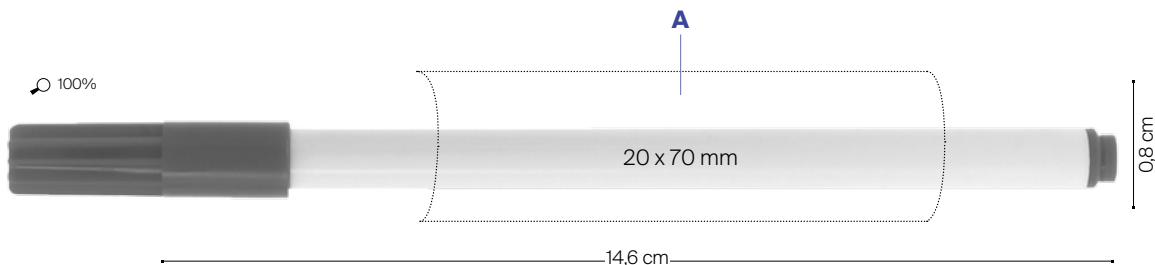

A> SP: max. 1 colour

Barrel / Trims / Ink
OPAQUE

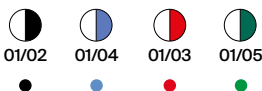



Great Eraser White Board Marker

EN > Ideal for use on **dry erase boards, glass and most non-porous surfaces.**

Easily erases with a dry cloth, tissue or felt eraser!

FR > Idéal pour une utilisation sur **tableau blanc, verre et sur la plupart des surfaces non poreuses.**

S'efface facilement avec un chiffon sec, un papier-mouchoir ou un effaceur-feutre !

ES > Ideal para usarlo en **pizarras blancas, de cristal y en la mayoría de superficies no porosas.**

¡Se borra fácilmente con un paño seco, un pañuelo o un borrador de fieltro!

DE > Ideal für den Gebrauch auf **Whiteboards, Glas und den meisten nicht porösen Oberflächen.**

Leicht löschar mit trockenem Textil, Tissuetuch oder Vlies-Tafelwischer!

IT > Ideale per **lavagne cancellabili a secco, vetro e la maggior parte delle superfici non porose.**

Si cancella facilmente con un panno asciutto, un fazzoletto o un cancellino in feltro!



Iconic BIC® Boy is embossed

100%

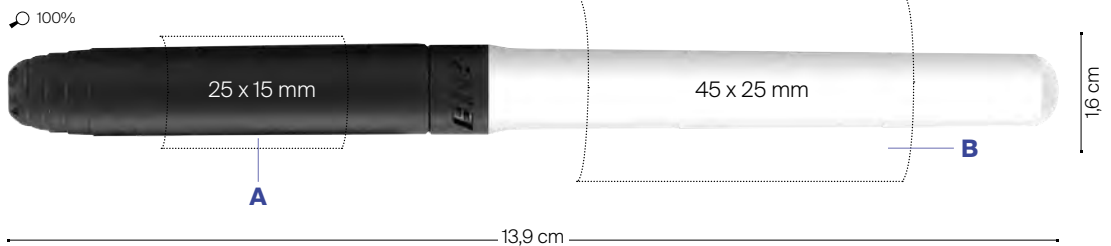

1213
White Board Marker
Marqueur pour ardoise blanche
Marcador de pizarra blanca
White Board Marker
Pennarello da lavagna bianca

A / B > SP: max. 3 colours

Barrel / Cap and Trims / Ink
OPAQUE

01/02

MOQ: 250 u.



250
±2.7 Kg



Mark-it Permanent Marker

- EN >** Fade-resistant, bright and quick drying ink for clean and precise writing. **Textured rubberised grip for comfort and control.**
- FR >** Encre résistante à la décoloration, brillante et à séchage rapide, pour une écriture propre et précise. **Grip en caoutchouc pour plus de praticité et de contrôle.**
- ES >** Tinta resistente a la decoloración, brillante y de secado rápido para una escritura limpia y precisa. **Grip de goma para mayor comodidad y control.**
- DE >** Lichtechte, leuchtende und schnelltrocknende Tinte für sauberes, präzises Schreiben. **Strukturierte, gummierte Griffzone für mehr Komfort und Sicherheit.**
- IT >** Inchiostro che non scolorisce, brillante e a rapida asciugatura per una scrittura pulita e precisa. **Impugnatura in gomma per maggiore comodità e controllo.**



1214
 Marker
 Marqueur
 Marcador
 Permanent Marker
 Pennarello

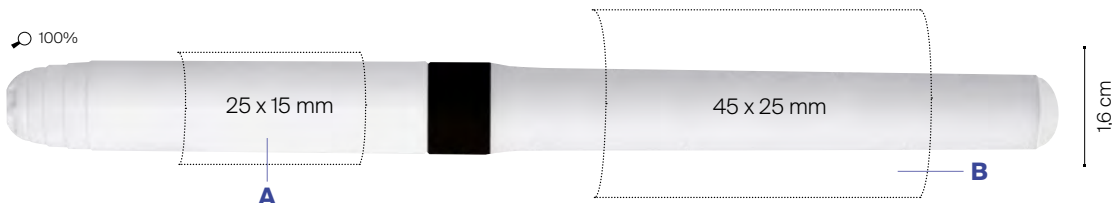

A / B > SP: max. 3 colours

13,9 cm

Barrel and Cap / Trims / Ink
 OPAQUE

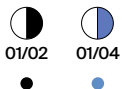

MOQ: 250 u. ± 2,8 Kg



Permanent Marker **eco**olutions®

EN > Writes on most surfaces. **Quick-drying and low-odour ink.** Cap with security lock. **Large ink capacity.**

FR > Écrit sur la majorité des surfaces. **Séchage rapide et parfum discret.** Capuchon avec fermeture de sécurité. Grande zone d'impression. **Grand volume d'encre.**

ES > Escribe sobre la mayoría de superficies. **Secado rápido y olor suave.** Capuchón con cierre de seguridad. Gran área de impresión. **Gran capacidad de tinta.**

DE > Schreibt auf fast allen Oberflächen. **Schnelltrocknende, geruchsarme Tinte.** Kappe mit Sicherheitsverschluss. **Großes Tintenvolumen.**

IT > Scrive su quasi tutte le superfici. **Asciugatura rapida e odore gradevole.** Cappuccio con chiusura di sicurezza. Ampia area di stampa. **Grande quantità di inchiostro.**

*** Made with 51% recycled material.**

The percentage is calculated based on the total weight of the product.

Add the Möbius loop to your artwork at no additional charge. Please be sure to specify "Print the Möbius loop" on your order. (Möbius loop imprint defaults to left-hand hand corner.)



100%

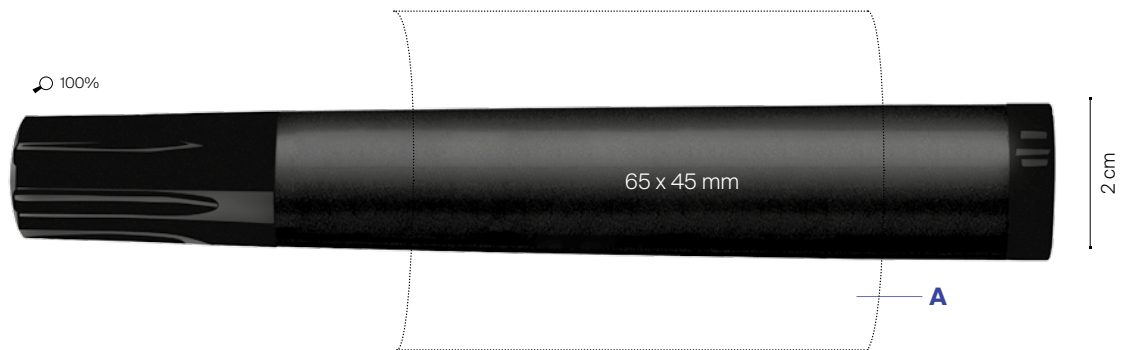

100%

65 x 45 mm

2 cm

***1210**
Marker
Marqueur
Marcador
Permanent Marker
Pennarello

A> SP: max. 1 colour

13,8 cm

Barrel and Cap
OPAQUE



MOQ: 250 u.



125
± 2,6 Kg



If you want more information about our BIC® Ecolutions & how it's made visit: bicgraphic.eu/ie/sustainable-development.html.



Brite Liner® Grip

- EN > Highlight your message with precision and control thanks to the textured rubberised grip.
- FR > Donnez de l'impact à votre message par la précision et le contrôle, grâce au grip en caoutchouc.
- ES > Resalta tu mensaje con precisión y control gracias al grip de goma.
- DE > Markieren Sie Ihre Botschaft präzise und kontrolliert dank der strukturierten, gummierten Griffzone.
- IT > Fai risaltare il tuo messaggio con precisione e controllo grazie all'impugnatura in gomma.

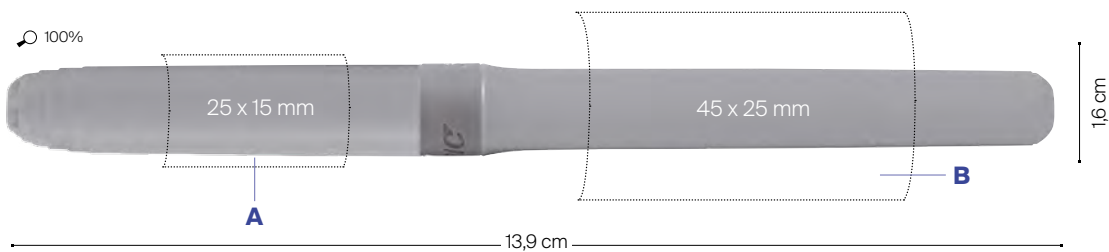

1192
Highlighter
Surligneur
Marcador
Leuchtmarker
Evidenziatore

A / B > SP: max. 3 colours

Barrel / Ink
OPAQUE



MOQ: 250 u.



± 2,8 Kg



Brite Liner® Grip XL

- EN >** Chisel tip for **broad highlighting** and **fine underlining**. Textured **rubberised grip** for comfort and control.
- FR >** Pointe biseautée, et **large pour surligner ou fine pour souligner**. **Grip en caoutchouc** pour un confort et un contrôle améliorés.
- ES >** Punta biselada, de **perfil ancho para resaltar o de perfil delgado para subrayar**. **Grip de goma** para un mejor confort y control.
- DE >** Keilspitze für **breites Markieren** und **feines Unterstreichen**. Strukturierte, **gummierte Griffzone** für mehr Komfort und Sicherheit.
- IT >** Punta smussata, **ampia per evidenziare o sottile per sottolineare**. **Impugnatura in gomma** per maggiore comfort e controllo.



HIGHLIGHTERS & MARKERS

BIC® WRITING INSTRUMENTS

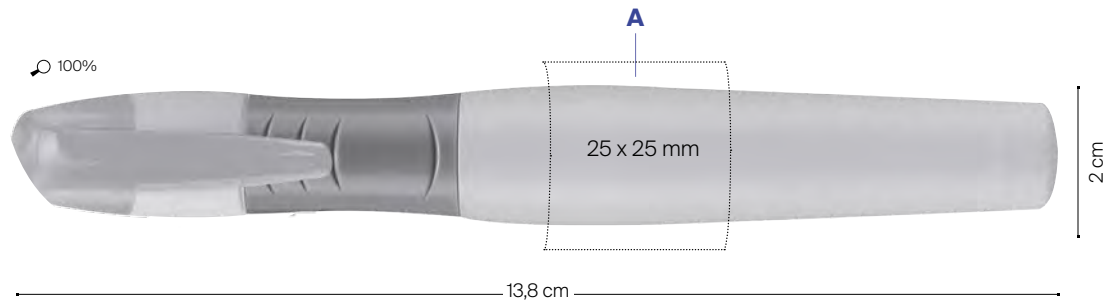

1193
 Highlighter
 Surligneur
 Marcador
 Leuchtmarker
 Evidenziatore

A > SP: max. 1 colour

Barrel / Ink
OPAQUE







Pencils

Wood-free pencil made with recycled synthetic resin material, that will not splinter in the event of breaking. Resistant HB grade lead. Supplied with ready sharpened point.



Matic®

By the expert in...
Writing Instruments



- EN > Stay sharp with this first-class mechanical pencil! It is solid and resistant, **writes 2.5 times more than a graphite pencil, and never needs sharpening!**
- FR > Toujours préparé avec ce porte-mines de qualité supérieure. Solide et résistant, il **écrit 2,5 fois plus qu'un crayon de graphite et n'a jamais besoin d'être taillé !**
- ES > Siempre preparado con este portaminas de calidad superior. Es sólido y resistente. **¡Escribe 2,5 veces más que un lápiz de grafito, y nunca necesita afilarse!**
- DE > Dieser erstklassige Feinminenstift bleibt immer spitz! Solide und unempfindlich, **schreibt 2,5mal weiter als ein klassischer Bleistift und muss nie angespitzt werden!**
- IT > Sempre pronto, con questo portamine di prima classe. Solido e resistente, **scrive 2 volte e mezzo in più di una matita in grafite e non c'è mai bisogno di temperarla.**

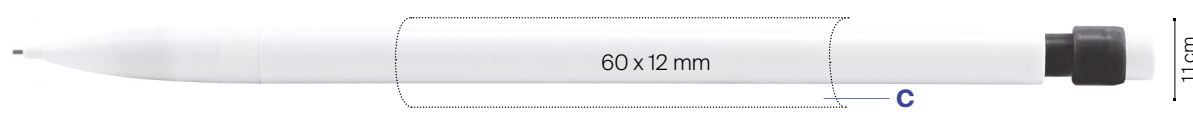
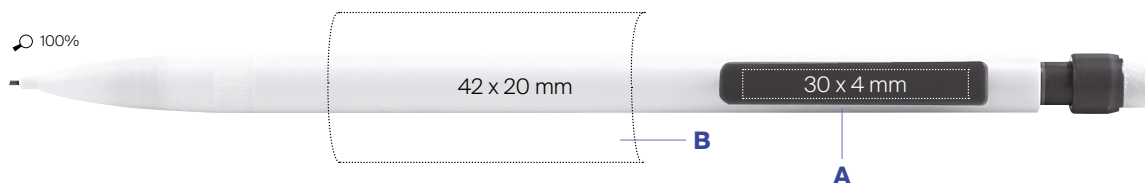

1120
Mechanical pencil
Porte-mine
Portaminas
Druckbleistift
Portamine

A> SP: max. 1 colour
B / C> SP: max. 2 colours

15 cm

1120
Barrel and Trims
OPAQUE



MOQ: 500 u.





Matic® ecolutions®

- EN >** Stay sharp with this first-class mechanical pencil! It is solid and resistant, **writes 2.5 times more than a graphite pencil, and never needs sharpening!**
- FR >** Toujours préparé avec ce porte-mines de qualité supérieure. Solide et résistant, il **écrit 2,5 fois plus qu'un crayon de graphite et n'a jamais besoin d'être taillé !**
- ES >** Siempre preparado con este portaminas de calidad superior. Es sólido y resistente. **¡Escribe 2,5 veces más que un lápiz de grafito, y nunca necesita afilarse!**
- DE >** Dieser erstklassige Feinminienstift bleibt immer spitz! Solide und unempfindlich, **schreibt 2,5mal weiter als ein klassischer Bleistift und muss nie angespitzt werden!**
- IT >** Sempre pronto, con questo portamine di prima classe. Solido e resistente, **scrive 2 volte e mezzo in più di una matita in grafite e non c'è mai bisogno di temperarla.**

*** Made with 65% recycled material.**

The percentage is calculated based on the total weight of the product.



PENCILS

BIC® WRITING INSTRUMENTS

Add the Möbius loop to your artwork at no additional charge. Please be sure to specify "Print the Möbius loop" on your order. (Möbius loop imprint defaults to left-hand hand corner)

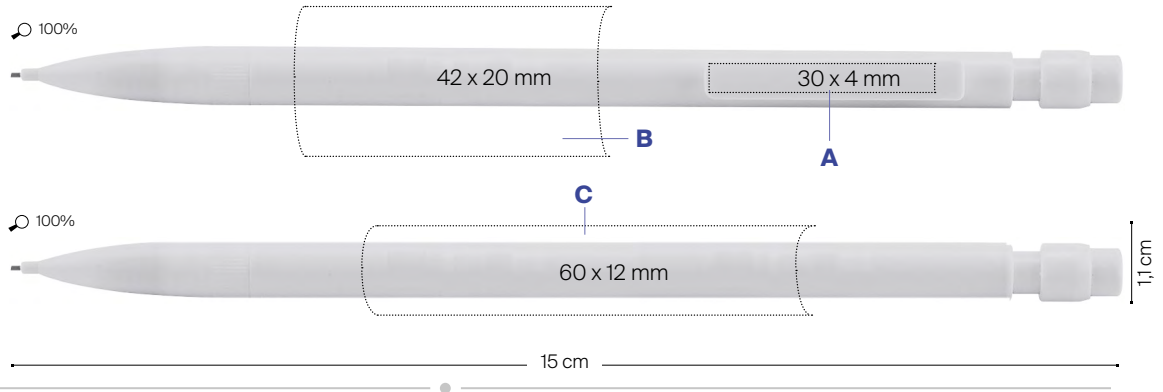

***1E40**

Mechanical pencil
Porte-mine
Portaminas
Druckbleistift
Portamine

A > SP: max. 1 colour

B / C > SP: max. 2 colours

Barrel and Trims
OPAQUE



MOQ: 500 u.



500
± 3,1 Kg



If you want more information about our BIC® Ecolutions & how it's made
visit: bicgraphic.eu/ie/sustainable-development.html.



Matic® Quartz

- EN >** Our first-class mechanical pencil featuring **transparent barrel combined with coloured inner barrel and trim.**
- FR >** Notre premier porte-mines au corps **transparent qui associe les caractéristiques de teinte du corps interne.**
- ES >** Nuestro primer portaminas con cuerpo **transparente cuyos atributos combinan con el color del cuerpo interno.**
- DE >** Unser erstklassiger Feinminenstift mit **transparentem Schaft, farbigem Innenschaft und farbigen Verzierungen.**
- IT >** Il nostro classico portamine con corpo **trasparente e interni colorati.**



1121 Quartz

100%

42 x 20 mm

1124 Quartz Metallic

100%

42 x 20 mm

1121 Quartz/
1124 Quartz Metallic
Mechanical pencil
Porte-mine
Portaminas
Druckbleistift
Portamine

1121 Quartz / 1124 Quartz Metallic

100%

60 x 12 mm

1,1 cm

A / B > SP: max. 2 colours

15 cm

1121 Quartz
Barrel and Trims
OPAQUE

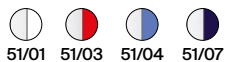

1124 Quartz Metallic
Barrel and Trims
OPAQUE



MOQ: 500 u.





Matic® Grip

- EN >** Comfortable **soft touch rubber grip**. Opaque and metallic colours available.
- FR >** Grip confortable en **caoutchouc doux**. Disponible en couleurs opaques et métalliques.
- ES >** Confortable **grip de goma de tacto suave**. Disponible en colores opacos y metálicos.
- DE >** Komfortable **Soft-Touch Gummigriffzone**. Opake und Metallic-Farben verfügbar.
- IT >** Impugnatura con **grip in morbida gomma**. Disponibile in colori opachi e metallizzati.



PENCILS

BIC® WRITING INSTRUMENTS

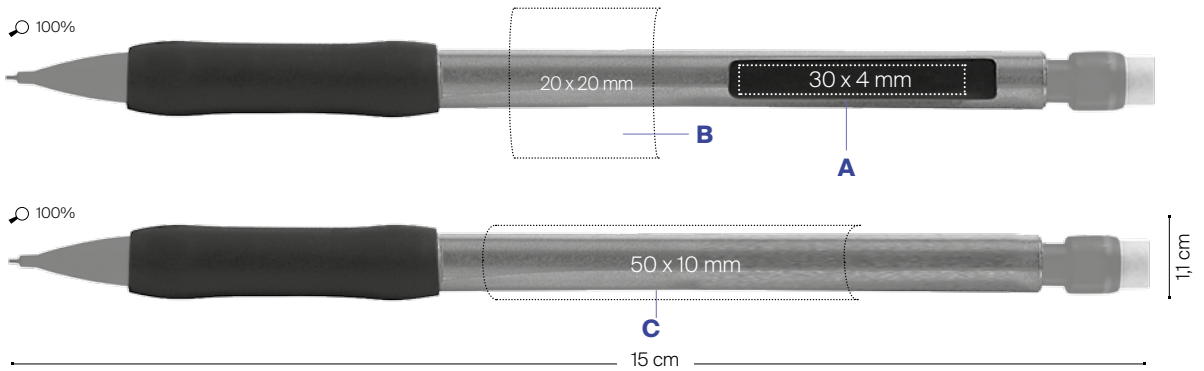

1122 /
1127 Metallic
Mechanical pencil
Porte-mine
Portaminas
Druckbleistift
Portamine

A > SP: max. 1 colour
B / C > SP: max. 2 colours

1122
Barrel / Trims
OPAQUE



1127 Metallic
Barrel / Trims
OPAQUE



* While stock lasts

MOQ: 500 u.





- EN >** Wood-free pencil made with recycled synthetic resin material, that will **not splinter** in the event of breaking. Resistant HB grade lead.
- FR >** Crayon papier en résine synthétique, **sans bois**, fabriqué à partir de matière recyclée et qui ne **fait pas d'écharde** en cas de casse. Mine de graphite HB résistante.
- ES >** Lápiz de grafito de resina sintética, **sin madera**, hecho con un material reciclado, que **no se astilla** en caso de rotura. Resistente mina de grafito HB.
- DE >** Holzfreier Bleistift aus Kunstharz. Hergestellt aus Recyclingmaterial, das **nicht splittert**, selbst wenn es zerbricht. Unempfindliche HB-Mine.
- IT >** Matita di grafite di resina sintetica, **senza legno**, realizzata con materiale riciclato, che **non si scheggia** in caso di rottura. Resistente mina in grafite HB.

**** Made with 54% recycled plastic (1150)**
*** Made with 46% recycled plastic (1151/1154)**
 The percentage is calculated based on the total weight of the product.



Add the Möbius loop to your artwork at no additional charge. Please be sure to specify "Print the Möbius loop" on your order. (Möbius loop imprint defaults to left-hand hand corner.)



1150**
 Graphite pencil cut end
 Crayon graphite bout coupé
 Lápiz de grafito sin goma
 Graphit-Bleistift ohne Radiergummi
 Matita senza gomma

1151*/1154* Colour Connection
 Graphite pencil with eraser
 Crayon graphite bout gomme
 Lápiz de grafito con goma
 Graphit-Bleistift mit Radiergummi
 Matita con gomma

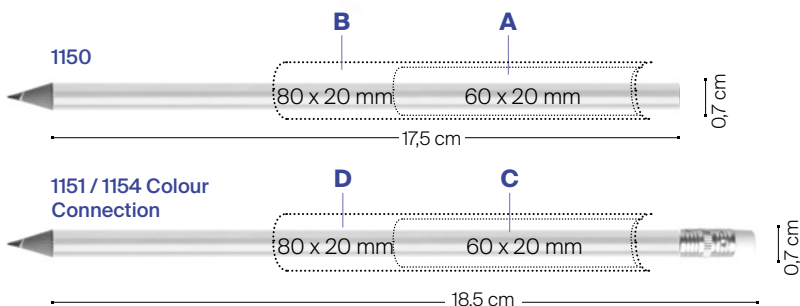

A / C > SP: max. 2 colours
B / D > SP: max. 1 colour

1150/1151/1154
 Barrel
 OPAQUE



1151
 Eraser/Ferrule



1154 Colour Connection
 Eraser

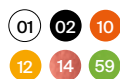

Ferrule

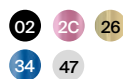

MOQ: 500 u.



* Only 1150 & 1151



If you want more information about our BIC® Ecolutions & how it's made
 visit: bicgraphic.eu/ie/sustainable-development.html.



MIX & MATCH

Evolution[®] Digital Evolutions[®] & Metallic Digital

By the expert in...
In digital printing

PENCILS

BIC[®] WRITING INSTRUMENTS

- EN >** 360° photo quality **full-colour** imprint wood-free pencil in synthetic resin, material made with 54% recycled material, that will not splinter in the event of breaking. Resistant HB grade lead. Metallic finish.
- FR >** Crayon papier en résine synthétique, sans bois, fabriqué à partir de matière recyclée, imprimé **en couleur** en qualité photo à 360° et ne faisant pas d'écharde lorsqu'il se casse. Mine HB résistante, finition métallique.
- ES >** Lápiz de grafito de resina sintética con impresión 360° con calidad fotográfica **a todo color** hecho de material reciclado que no se astilla en caso de rotura. Resistente mina de grafito. Acabado metálico.
- DE >** 360°-**Vollfarbdruck** in Fotoqualität auf holzfreiem Bleistift aus Kunstharz. Hergestellt aus 54 % Recyclingmaterial, das nicht splittert, selbst wenn es zerbricht. Widerstandsfähige HB-Graphitmine mit Metallic-Oberfläche.
- IT >** Matita con stampa **a colori** a 360° e con qualità fotografica, prodotta senza legno in resina sintetica e con materiale riciclato, che non si scheggia in caso di rottura. Mina resistente con durezza HB, finitura metallica.

- ** Made with 54% recycled plastic (1962/1879)
- * Made with 46% recycled plastic (1960/1964/1871/1885)

The percentage is calculated based on the total weight of the product.

Add the Möbius loop to your artwork at no additional charge. Please be sure to specify "Print the Möbius loop" on your order. (Möbius loop imprint defaults to left-hand hand corner.)



1879 / 1962** Metallic**
Graphite pencil cut end
Crayon graphite bout coupé
Lápiz de grafito sin goma
Graphit-Bleistift ohne Radiergummi
Matita senza gomma

**1871 / 1960* Metallic / 1885* Colour Connection
Metallic / 1964* Colour Connection**
Graphite pencil with eraser
Crayon graphite bout gomme
Lápiz de grafito con goma
Graphit-Bleistift mit Radiergummi
Matita con gomma

A / C > DG: full-colour (area for images)
B / D > DG: full-colour (area for text)

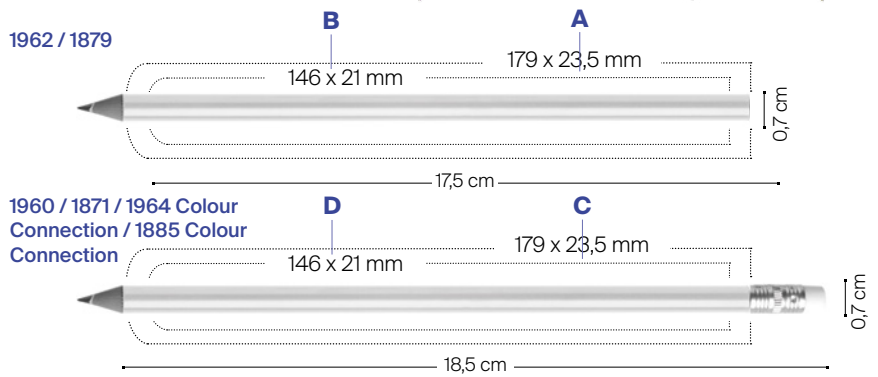

1879/1871/1885 Barrel OPAQUE	1962 Barrel OPAQUE	1871/1960 Eraser/Ferrule	1964 colour connection Barrel OPAQUE	1964 Colour Connection 1885 Colour Connection Eraser	Ferrule
(01)	(47) (26)	(01) (26)	(47) (26)	(01) (02) (07) (10) (12) (14) (59)	(02) (2C) (26) (34) (47)

MOQ: 500 u. ±3.5 Kg



If you want more information about our BIC[®] Evolutions & how it's made
visit: bicgraphic.eu/ie/sustainable-development.html.



Colouring pens



BIC® PLASTIDECOR® set of 6 crayons

By the expert in...
Writing Instruments



COLOURING PENS

BIC® WRITING INSTRUMENTS

- EN >** The ideal promotional item supported by the recognised brands BIC® and PLASTIDECOR®. Set of 6 crayons suitable for children aged 2+: **extra clean, won't stain hands or clothes, resistant and easy to sharpen!** Presented in a fully customized carton wallet.
- FR >** Un article promotionnel idéal, bénéficiant des apports de deux marques reconnues : BIC® et PLASTIDECOR®. Set de 6 crayons de cire pour enfants de plus de 2 ans : **extra propres, ne tachent ni les mains ni les vêtements, résistants et faciles à tailler !** Présentés dans un étui en carton entièrement personnalisable.
- ES >** El producto promocional ideal para niños con el respaldo de las reconocidas marcas: BIC® y PLASTIDECOR®. Set de 6 ceras apropiadas para niños a partir de 2 años: **extra limpias, no manchan las manos ni la ropa, resistentes y ¡fáciles de afilar!** Presentado en un estuche de cartón totalmente personalizado.
- DE >** Das ideale Werbegeschenk für Kinder, unterstützt durch die renommierten Marken BIC® und PLASTIDECOR®. Set mit sechs Wachsmalkreiden für Kinder ab zwei Jahren. **Besonders sauber, hinterlässt keine Flecken an den Händen oder der Kleidung, widerstandsfähig und einfach anzuspitzen!** Präsentiert in einer vollflächig personalisierbaren Kartonhülle.
- IT >** L'articolo promozionale perfetto supportato dai marchi di successo BIC® e PLASTIDECOR®. Set di 6 pastelli adatto ai bambini di età superiore ai 2 anni: **ultra puliti, non macchiano mani né vestiti, resistenti e facili da temperare!** Presentato in un astuccio di cartone completamente personalizzabile.

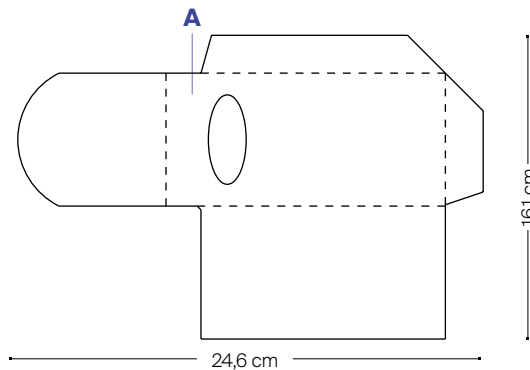

1201

Colouring crayons
Crayons à la cire pour
coloriage
Ceras de colores
Bunte Wachsmalkreiden
Pastelli a cera

A> DG: 4-colour process

BOX

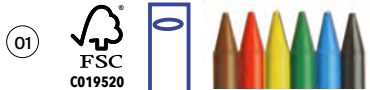

MOQ: 500 u.

84
± 3,8 Kg

MADE IN
FRANCE



Visa® set of 6 felt pens

- EN >** Set of 6 fine felt pens **ideal for creating great drawings with bright colours.** Presented in a fully customized carton wallet.
- FR >** Set de 6 feutres fins, **parfaits pour faire de superbes dessins aux couleurs vives.** Présentés dans un étui en carton entièrement personnalisable.
- ES >** Set de 6 rotuladores **ideales para crear magníficos dibujos con colores brillantes.** Presentado en un estuche de cartón totalmente personalizado.
- DE >** Set mit 6 Fasermalern - **ideal für großartige Gemälde in leuchtenden Farben.** Präsentiert in einer vollflächig personalisierbaren Kartonhülle.
- IT >** Set di 6 pennarelli a punta fine **perfetti per realizzare incredibili disegni con colori vivaci.** Presentato in un astuccio di cartone completamente personalizzato.

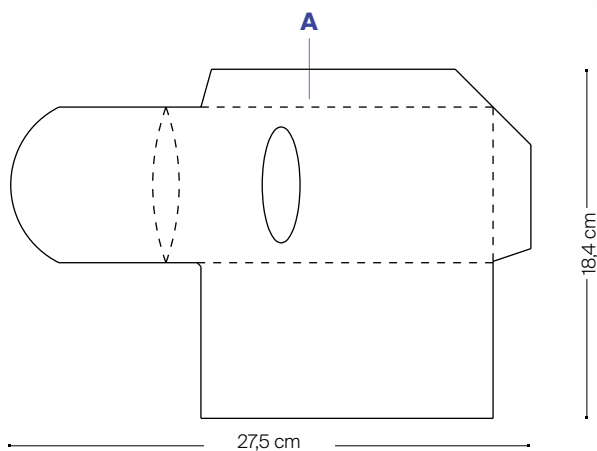

1203

Felt pens
Feutres fins
Rotuladores finos
Fasermalern
Pennarelli

A> DG: 4-colour process

BOX

01



MOQ: 500 u.

60
± 2,4 Kg





EVOLUTION[®] ecolutions[®] set of 6 colouring pencils

- EN >** Ultra resistant pencils that are easy to sharpen ideal for everyday drawing and colouring. Presented in a fully customised carton wallet.
- FR >** Crayons ultra-résistants faciles à tailler, parfaits pour les dessins et coloriages quotidiens. Présentés dans un étui en carton entièrement personnalisable.
- ES >** Lápices ultra resistentes que son fáciles de afilar e ideales para dibujar y colorear todos los días. Presentados en un estuche de cartón totalmente personalizado.
- DE >** Sehr stabile Farbstifte, die einfach anzuspitzen sind. Ideal für tägliches Zeichnen und Malen. Präsentiert in einer vollflächig personalisierbaren Kartonhülle.
- IT >** Matite ultra resistenti e facili da temperare, perfette per disegnare e colorare tutti i giorni. Presentate in un astuccio di cartone completamente personalizzato.

Add the Möbius loop to your artwork at no additional charge. Please be sure to specify "Print the Möbius loop" on your order. (Möbius loop imprint defaults to left-hand hand corner.)



*** Made with 50% recycled material.**

The percentage is calculated based on the total weight of the product.



80%

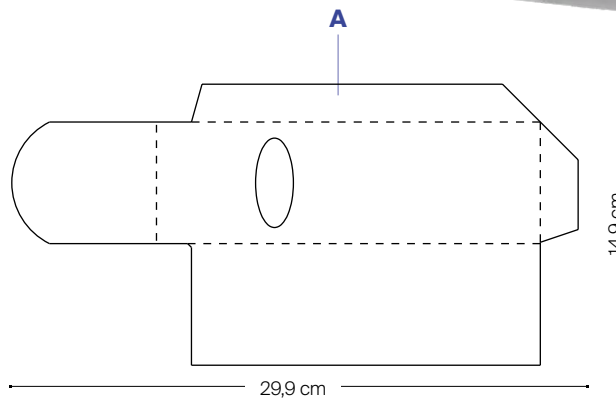

1202

Colouring pencils
Crayons de couleur
Lápices de colores
Farbstifte
Matite colorate

A> DG: 4-colour process

BOX

01



MOQ: 500 u.

60
± 2,6 Kg



If you want more information about our BIC[®] Ecollections & how it's made visit: bicgraphic.eu/ie/sustainable-development.html.





set of 6 colouring pencils

- EN >** Colouring set of 6 premium pencils from the historic brand Conté®. The pencils are **wood-free**, **have a strong lead and provide bright colours**, and are presented into a fully-customised carton wallet.
- FR >** Set de 6 crayons haut de gamme de la célèbre marque Conté®. Ces crayons **sans bois possèdent une mine résistante et des couleurs vives**, et sont présentés dans un étui en carton entièrement personnalisable.
- ES >** Set de 6 lápices de colores premium de la histórica marca Conté®. Los lápices **sin madera tienen una fuerte mina y proporcionan colores brillantes**. Son presentados en un estuche de cartón totalmente personalizado.
- DE >** Farbset mit 6 Premium-Farbstiften der renommierten Marke Conté. Die Stifte sind **holzfrei, verfügen über eine starke Mine in leuchtenden Farben** und präsentieren sich in einer vollflächig personalisierbaren Kartonhülle.
- IT >** Set per colorare composto da 6 matite premium del marchio storico Conté®. Le matite sono prodotte **senza legno, con una mina resistente, colori brillanti** e sono presentate in un astuccio di cartone completamente personalizzato.

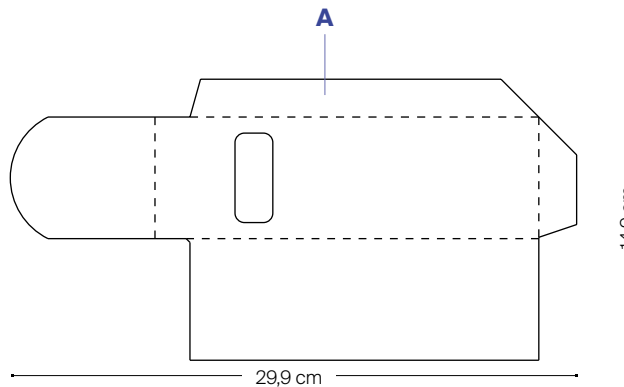

1178

Colouring pencils
Crayons de couleur
Lápices de colores
Farbstifte
Matite colorate

A> DG: 4-colour process

BOX

01



MOQ: 500 u.

60
± 2,2 Kg



BIC® PLASTIDÉCOR® colouring set & EVOLUTION® ECOLOUTIONS® colouring set & VISA® colouring set

EN > Set includes: colourings in a fully personalised box and a 16 pages colouring book for kids with a fully personalised cover. Set presented in a cotton drawstring bag with BIC® logo.

FR > Le set inclut : les crayons, présentés dans une boîte entièrement personnalisable, et un cahier de coloriage pour enfants de 16 pages, dont la couverture est elle aussi entièrement personnalisable. Le set se présente dans un sac en coton à cordon coulissant, orné du logo BIC®.

ES > El set incluye los colores en una caja de cartón totalmente personalizable y un libro para colorear de 16 hojas para niños con una portada totalmente personalizable. El set está presentado en una bolsa de cordón de algodón con el logo BIC®.

DE > Set mit Farbstiften in einer vollflächig personalisierbaren Box und ein 16-seitiges Malbuch für Kinder mit vollflächig personalisierbarem Cover. Präsentiert in einem Baumwoll-Kordelzugbeutel mit BIC® Logo.

IT > Il set include: pastelli in un astuccio completamente personalizzato e un libro da colorare di 16 pagine con copertina completamente personalizzata. Set presentato in un sacchetto di cotone con cordoncino e logo BIC®.



BIC® Plastidecor® colouring set

SP (bag): 1294

OT (bag): 1298

NO IMPRINT (bag): 1302

BIC® Evolution® Ecolutions® colouring set

SP (bag): 1293

OT (bag): 1297

NO IMPRINT (bag): 1301

BIC® Visa® colouring set

SP (bag): 1291

OT (bag): 1295

NO IMPRINT (bag): 1299

A > SP: max 2 colours

B > OT: full-colour

C > DG: 4-colour process

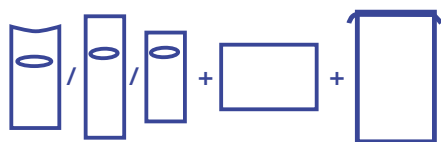
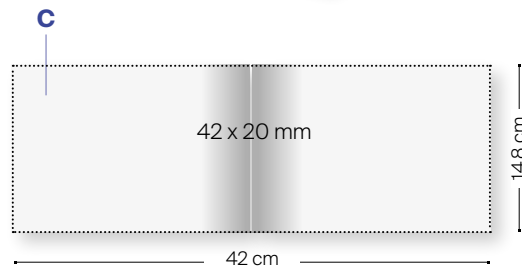
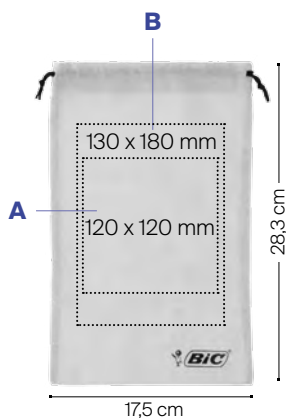

MOQ: 500 u.

1294/ 1298/ 1302	1293/ 1297/ 1301	1291/ 1295/ 1299
------------------------	------------------------	------------------------

100 ±10,8Kg	100 ±10 Kg	100 ±10,6 Kg
----------------	---------------	-----------------

Conté®
- since / depuis 1795 -

by BIC®

colouring set

EN > Set includes: 6 Conté® colouring pencils in a **fully personalised box and a 16 pages colouring book for adults with a fully personalised cover**. Set presented in a cotton drawstring bag with BIC® logo.

FR > Le set inclut : 6 crayons de couleur Conté®, présentés dans une **boîte entièrement personnalisable, et un cahier de coloriage pour adultes de 16 pages, dont la couverture est elle aussi entièrement personnalisable**. Le set se présente dans un sac en coton à cordon coulissant, orné du logo BIC®.

ES > El set incluye 6 colores Conté® en una **caja de cartón totalmente personalizable y un libro para colorear de 16 hojas para adultos con una portada totalmente personalizable**. El set está presentado en una bolsa de cordón de algodón con el logo BIC®.

DE > Set mit 6 Conté-Farbstiften in einer **vollflächig personalisierbaren Box und einem 16-seitigen Malbuch für Erwachsene mit vollflächig personalisierbarem Cover**. Präsentiert in einem Baumwoll-Kordelzugbeutel mit BIC® Logo.

IT > Il set include: 6 pastelli Conté® per colorare inclusi in un **astuccio completamente personalizzato e un libro da colorare di 16 pagine con copertina completamente personalizzata**. Set presentato in un sacchetto di cotone con cordoncino e logo BIC®.

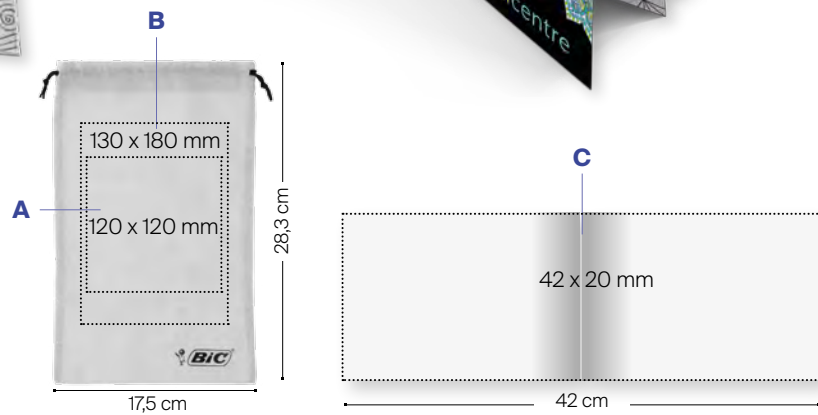
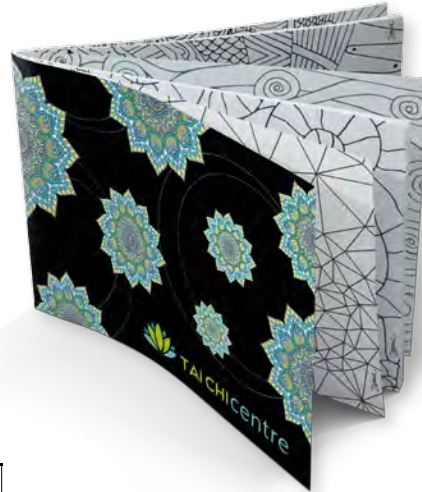
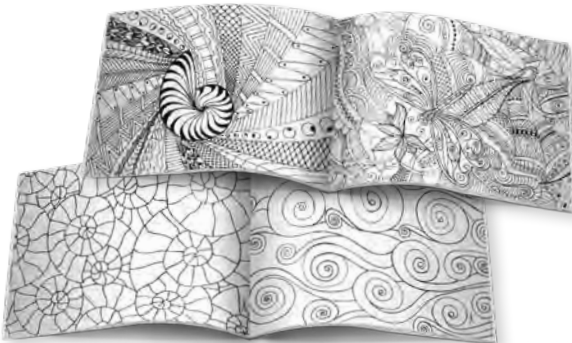

Conté® by BIC® colouring set

SP (bag): 1292

OT (bag): 1296

NO IMPRINT (bag): 1300

A> SP: max 2 colours

B> OT: full-colour

C> DG: 4-colour process

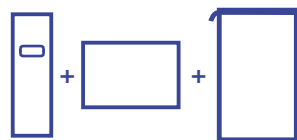

MOQ: 500 u.

100
±10,5 Kg

Tipp-Ex® Mini Pocket
Mouse *britePix™*



Tipp-Ex®

Mini Pocket Mouse

britePix™

- EN >** The worldwide recognised correction tape Tipp-Ex® in its compact size, **that provides an accurate application for both left and right-handeds with literally no dry time!**
- FR >** Une version compacte du ruban correcteur Tipp-Ex®, célèbre dans le monde entier, **pour une application précise par les gauchers comme par les droitiers, le tout sans séchage !**
- ES >** La mundialmente conocida cinta correctora Tipp-Ex® en su tamaño compacto **proporciona una aplicación precisa tanto para zurdos como para diestros y ¡sin tiempo de secado!**
- DE >** Das weltbekannte Korrekturband Tipp-Ex® in kompakter Größe, **das für Links- und Rechtshänder gleichermaßen akkurat anwendbar ist - ohne jegliche Trocknungszeit!**
- IT >** Il correttore a nastro Tipp-Ex®, conosciuto in tutto il mondo nel formato compatto, **offre un'applicazione precisa per mancini e destrorsi con un'asciugatura praticamente istantanea!**



100%

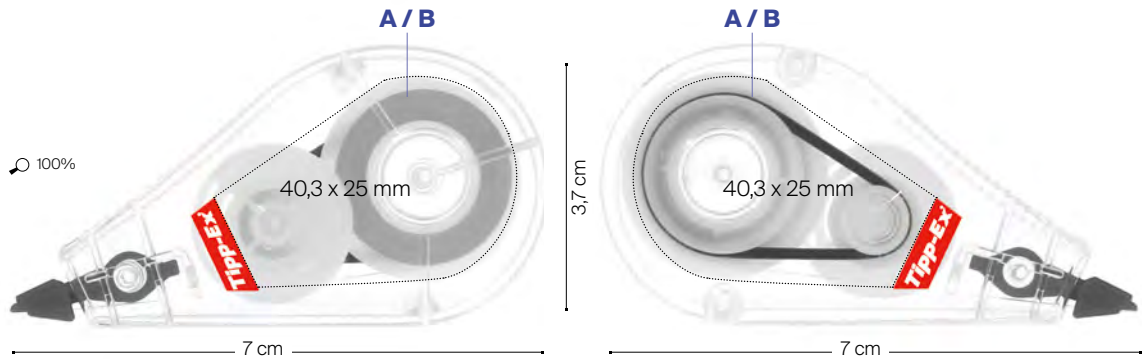

1354 britePix™

- A> BP: full-colour
- B> BP Texture: full-colour

Body
CLEAR

51



MOQ: 250 u.

288
± 3,2 Kg



Other Writing Instruments

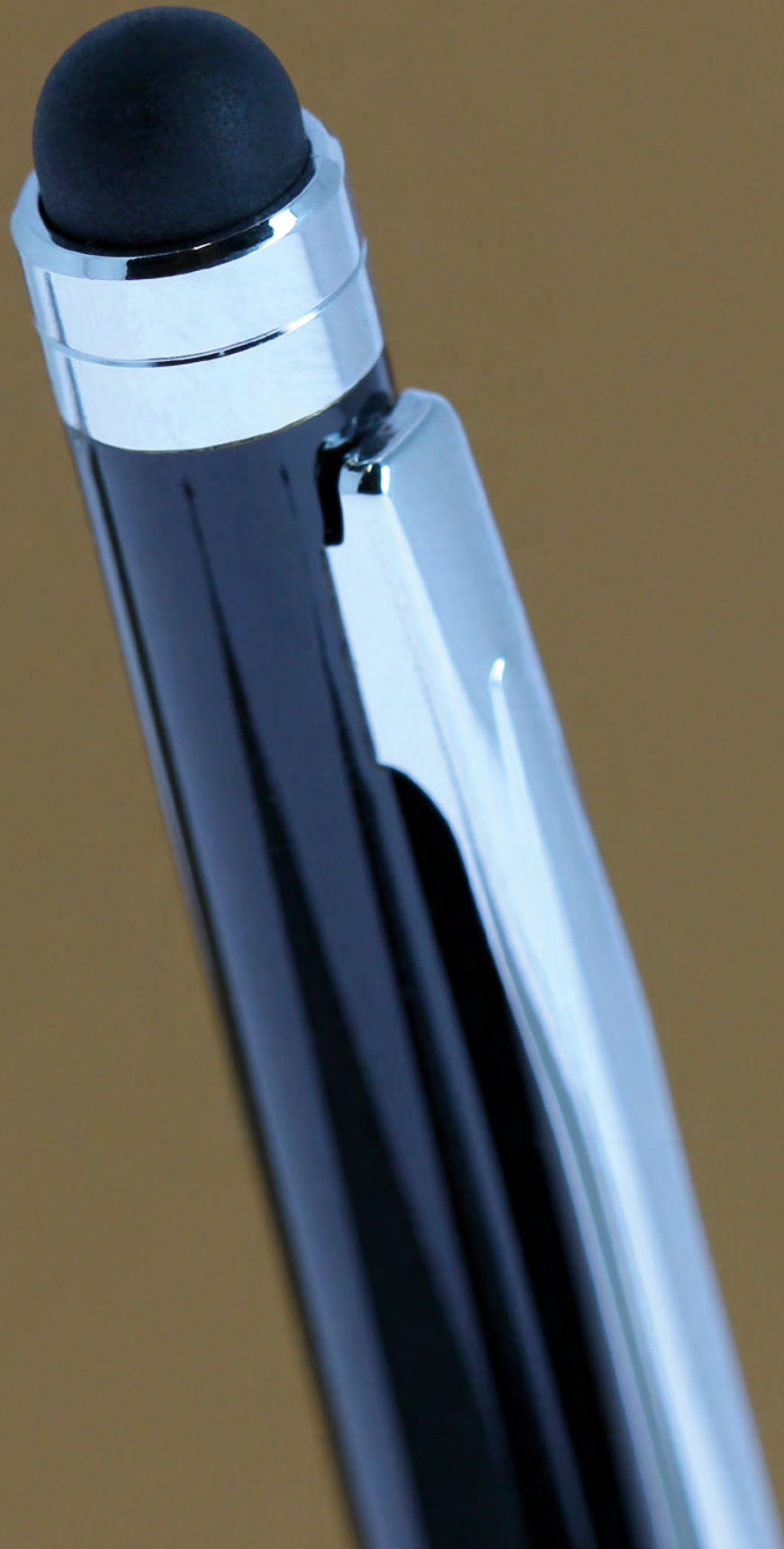

Basic pen

- EN >** Retractable ballpen available in a **large range of opaque colours** with polished finish.
- FR >** Stylo rétractable disponible dans une **vaste gamme de couleurs opaques** et une finition polie brillante
- ES >** Bolígrafo retráctil disponible en una **amplia gama de colores opacos** y un acabado pulido brillante.
- DE >** Druckkugelschreiber in **breiter Palette opaker Farben** mit polierter Oberfläche.
- IT >** Penna a scatto disponibile in un **ampia gamma di colori pieni** con finitura lucida.



PLASTIC PENS

OTHER WRITING INSTRUMENTS

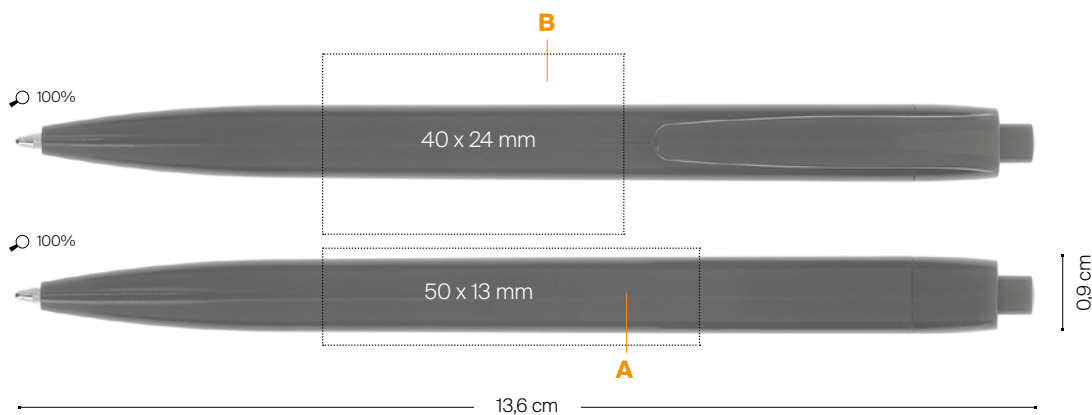

12010
 Ballpen
 Bille
 Bolígrafo
 Kugelschreiber
 Penna a sfera

A / B >
 SP: max. 1 colour



MOQ: 500 u.



1600
 ±12,5 Kg

Click pen

- EN >** Frosted coloured barrel with **soft rubberised grip and clear trim.**
- FR >** Corps coloré translucide avec zone de préhension caoutchoutée **douce au toucher et attribut de couleur claire.**
- ES >** Cuerpo de color translúcido con **grip de goma y detalles transparentes.**
- DE >** Farbig gefrosteter Schaft mit **softer, gummierter Griffzone und transparenten Verzierungen.**
- IT >** Fusto in colori satinati con **morbido grip in gomma e finitura trasparente.**

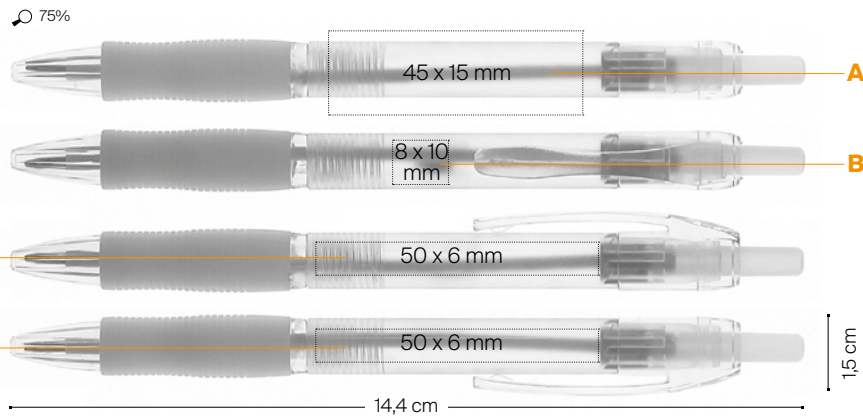

11748

Ballpen
Bille
Bolígrafo
Kugelschreiber
Penna a sfera

A / B > SP: max. 4 colours
C / D > PD: max. 4 colours



MOQ: 500 u.



Curved pen

- EN** > Retractable ballpen with **popular contoured design**.
- FR** > Stylo à bille rétractable avec **profil incurvé très apprécié**.
- ES** > Bolígrafo retráctil con un **popular diseño moldeado**.
- DE** > Druckkugelschreiber mit beliebtem, **konturiertem Design**.
- IT** > Penna a sfera a scatto con **design profilato**.



PLASTIC PENS

OTHER WRITING INSTRUMENTS

11242

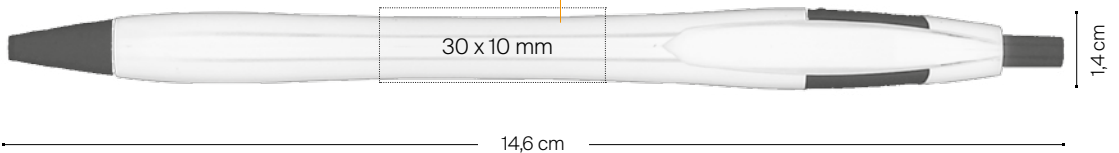

- 11242
- Ballpen
- Bille
- Bolígrafo
- Kugelschreiber
- Penna a sfera

A> SP: max. 2 colours

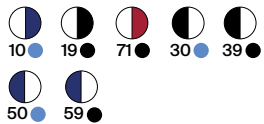

MOQ: 500 u.



Curved Grip pen

- EN >** Popular contoured design with **comfortable gripping section.**
- FR >** Profil incurvé très apprécié avec zone de **préhension confortable.**
- ES >** Popular diseño moldeado con **grip confortable.**
- DE >** Beliebtes, konturiertes Design mit **komfortabler Griffzone.**
- IT >** Il noto design profilato con **comodo grip sul fusto.**



100%

100%

11240
Ballpen
Bille
Bolígrafo
Kugelschreiber
Penna a sfera

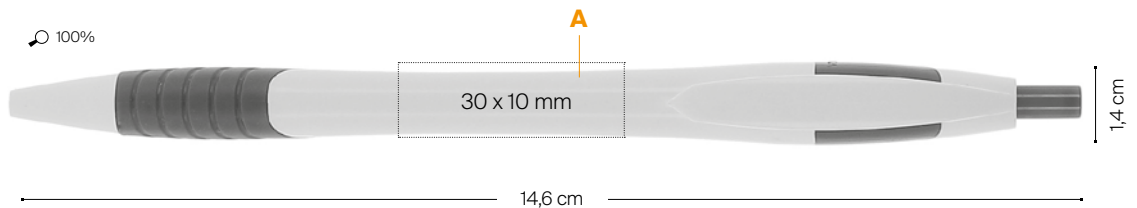

A> SP: max. 2 colours

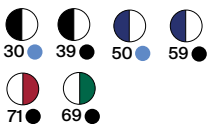

MOQ: 500 u.



Striped Grip pen & White Striped Grip pen

- EN** > Retractable ballpen with **popular contoured design**.
- FR** > Stylo à bille rétractable avec **profil incurvé très apprécié**.
- ES** > Bolígrafo retráctil con un **popular diseño moldeado**.
- DE** > Druckkugelschreiber mit beliebtem, **konturiertem Design**.
- IT** > Penna a scatto con **design profilato**.



PLASTIC PENS

OTHER WRITING INSTRUMENTS

11243 / 11303

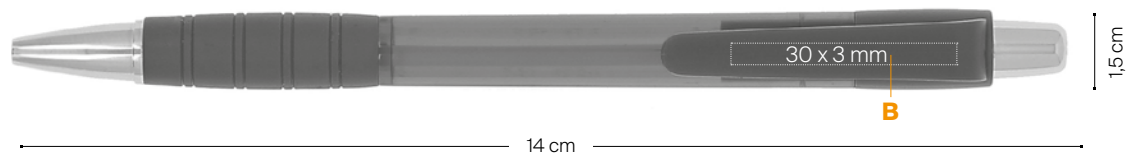
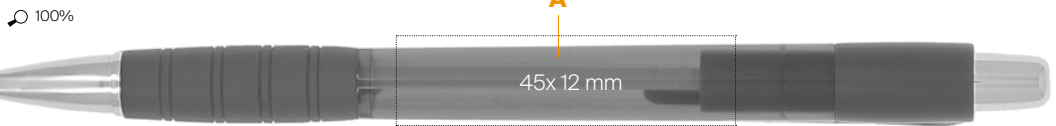

11243 / 11303

- Ballpen
- Bille
- Bolígrafo
- Kugelschreiber
- Penna a sfera

- A> SP: max. 2 colours
- B> PD: max. 1 colour

11243



11303



MOQ: 500 u.



Chrome Curved pen

- EN >** Retractable ballpen with popular contoured design featuring **shiny finish and shiny chrome trim.**
- FR >** Stylo à bille rétractable avec profil incurvé très apprécié, **finition brillante et attribut chromé.**
- ES >** Bolígrafo retráctil con un popular diseño moldeado. **Acabado brillante y detalles cromados brillantes.**
- DE >** Druckkugelschreiber mit beliebtem, konturierterem Design, mit **Glanzoberfläche und glänzenden Chromverzierungen.**
- IT >** Penna a scatto con design profilato, **finitura brillante e dettagli cromati.**



11307
Ballpen
Bille
Bolígrafo
Kugelschreiber
Penna a sfera

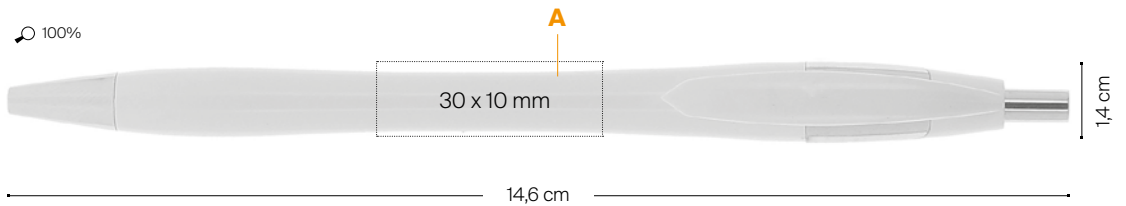

A > SP: max. 2 colours

10 20 30 50

MOQ: 500 u.



1000
±10 Kg

Sleek Stylus pen

- EN >** Multi-function slim profile ballpen with stylus on top for capacitive touchscreens.
Glossy-finish barrel and chrome-plated trim.
- FR >** Stylo à bille multifonction à profil fin avec embout de stylet pour écrans tactiles.
Corps avec finition brillante et attribut métallique.
- ES >** Bolígrafo ligero multifunción con stylus en la parte superior para pantallas táctiles. Cuerpo con acabado esmaltado y atributos cromados
- DE >** Multifunktions-Kugelschreiber mit schlankem Profil und Stylus am oberen Ende für kapazitive Touchscreens.
Glänzender farbiger Schaft mit chromfarbig glänzenden Elementen ergänzt.
- IT >** Penna a sfera multifunzione sottile con puntale per dispositivi touchscreen.
Fusto con finitura lucida e particolari cromati.



STYLUS PENS

OTHER WRITING INSTRUMENTS

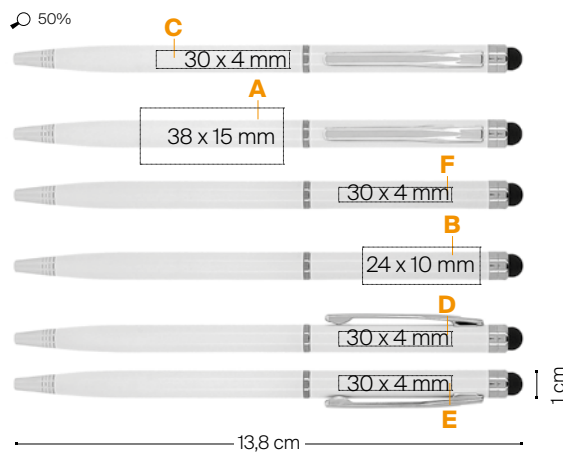

11666

Ballpen
 Bille
 Bolígrafo
 Kugelschreiber
 Penna a sfera

A > SP: max. 1 colour

B > SP: max. 2 colours

C / D / E / F > LE:

Laser engraving not available in yellow colour



MOQ: 300 u.



Sleek Stylus Matt pen

- EN >** Multi-function slim profile ballpoint pen with stylus for capacitive touchscreen devices on top. **Matt colour barrel featuring shiny chrome trim.**
- FR >** Stylo à bille multifonction à profil fin avec embout de stylet pour écrans tactiles. **Corps de couleur mate avec attribut chromé brillant.**
- ES >** Bolígrafo ligero multifunción con stylus para pantallas táctiles. **Cuerpo color mate combinado con atributos cromados.**
- DE >** Multifunktions-Kugelschreiber mit schlankem Profil und Stylus am oberen Ende für kapazitive Touchscreen-Geräte. **Mattierter, farbiger Schaft, mit chromfarbig glänzenden Elementen ergänzt.**
- IT >** Penna a sfera multifunzione sottile con puntale per dispositivi touchscreen. **Fusto con finitura opaca e particolari cromati.**

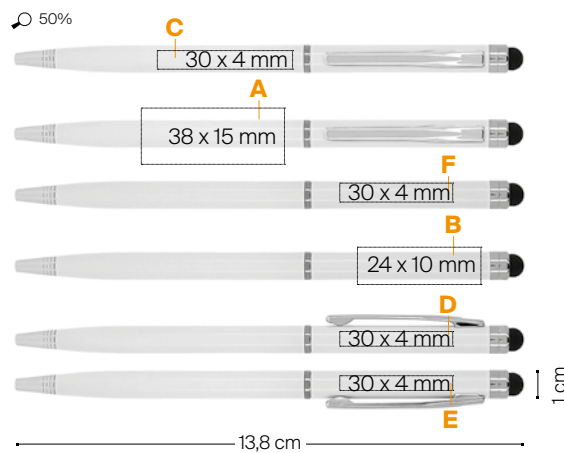

11747

Ballpen
Bille
Bolígrafo
Kugelschreiber
Penna a sfera

A > SP: max. 1 colour

B > SP: max. 2 colours

C / D / E / F > LE:

Laser engraving not available in silver colour



MOQ: 300 u.



Sleek Stylus Executive pen

- EN >** Multi-function slim-profile ballpen with stylus for capacitive touchscreens on top. **Matt colour barrel featuring matching colour shiny trim.**
- FR >** Stylo à bille multifonction à profil fin avec embout de stylet pour écrans tactiles. **Corps de couleur mate avec attribut chromé brillant de couleur assortie.**
- ES >** Bolígrafo ligero multifunción ligero para pantallas táctiles. **Cuerpo con acabado mate combinado con atributos brillantes a juego.**
- DE >** Multifunktions-Kugelschreiber mit schlankem Profil und Stylus am oberen Ende für kapazitive Touchscreen-Geräte. **Mattierter, farbiger Schaft, mit farblich passenden glänzenden Elementen ergänzt.**
- IT >** Penna a sfera multifunzione sottile con puntale per dispositivi touchscreen. **Fusto con finitura opaca e particolari lucidi.**



STYLUS PENS

OTHER WRITING INSTRUMENTS

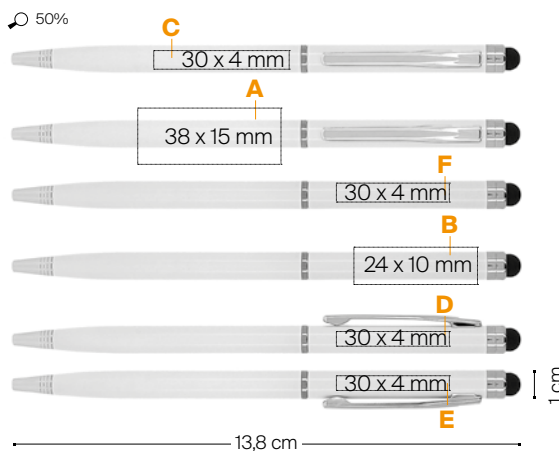

11976
 Ballpen
 Bille
 Bolígrafo
 Kugelschreiber
 Penna a sfera

A > SP: max. 1 colour
B > SP: max. 2 colours
C / D / E / F > LE:

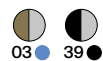

MOQ: 300 u.



Sprouts[™]



SPROUT[™]

Sprout[™] Pencil



- EN >** The pencil comes in a cardboard packaging where the user can see the instructions on how to use it and plant it. Printing personalisation is possible on the pencil as well as on the packaging, where you can print your logo on one side of the cardboard in full-colour possibilities.
- FR >** Le crayon est présenté dans un emballage cartonné contenant un mode d'emploi et un guide de plantation pour l'utilisateur. L'impression personnalisée est possible sur le crayon ainsi que sur l'emballage où vous pourrez imprimer votre logo en couleur sur l'un des côtés.
- ES >** El lápiz viene en una tarjeta donde se pueden ver las instrucciones de cómo utilizarlo y plantarlo. La personalización es posible tanto con grabado láser en el lápiz, como en el cartón, donde puedes imprimir tu logo a todo color en uno de los lados.
- DE >** Der Bleistift präsentiert sich in einer Kartonverpackung mit Gebrauchs- und Pflanzanleitung für den Endverbraucher. Der Personalisierungsdruck ist sowohl auf dem Bleistift als auch auf der Verpackung möglich, auf der Sie Ihr Logo auf der Kartonoberfläche im Vollfarbdruck erhalten.
- IT >** La matita è presentata in una confezione di cartone con le istruzioni per utilizzarla e piantarla. La personalizzazione di stampa è possibile sia sulla matita sia sulla confezione, sulla cui superficie di cartone puoi stampare il tuo logo su un lato con opzioni full-colour.



53063

53064

53062

50%

53063 / 53064 / 53062

53062 / 53065

53063 / 53064

A > L:

53066 / 53067

No imprint on barrel

53062

A > L:

B > DG: 4-colour process

53065

No imprint on barrel

B > DG: 4-colour process

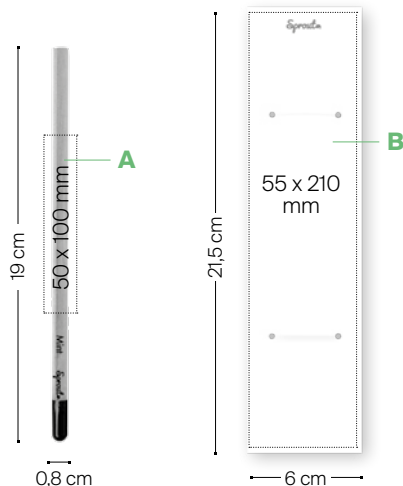

Use your pencil, then plant it and watch it grow. Sprout[™] is made of sustainably harvested wood and contains no lead.

FR > Utilisez votre crayon, puis plantez-le et observez comment il pousse. Le crayon Sprout[™] est fabriqué avec du bois issu de forêts gérées durablement et ne contient pas de plomb.

ES > Usa tu lápiz, luego plántalo y mira cómo crece. El lápiz Sprout[™] está hecho de madera procedente de bosques sostenibles y no contiene plomo.

DE > Schreiben Sie mit Ihrem Bleistift, pflanzen Sie ihn später ein und erleben, wie Pflanzen aus ihm wachsen. Sprout[™] ist aus nachhaltig bewirtschafteten Wäldern und enthält kein Blei.

IT > Usa la tua matita, poi piantala e guardala crescere. La matita Sprout[™] è fatta di legno reperito in modo sostenibile e non contiene piombo.

53066/53067/53065*
53063/ 53064/ 53062*

500 ±2,5 Kg 500 ±5 Kg 500 ±5 Kg



MOQ: 500 u.
*MOQ: 1000 u.



ADHESIVE NOTEPADS

- 157** BIC® 50 mm x 75 mm Adhesive Notepads
- 158** BIC® 68 mm x 75 mm Adhesive Notepads
- 159** BIC® 75 mm x 75 mm Adhesive Notepads
- 161** BIC® 101 mm x 75 mm Adhesive Notepads
- 161** BIC® 101 mm x 75 mm Alternating Sheet Imprint
- 163** BIC® 101 mm x 101 mm Adhesive Notepads
- 164** BIC® 101 mm x 152 mm Adhesive Notepads
- 162** BIC® Medium Adhesive Die Cut Notepads
- 160** BIC® Small Adhesive Die Cut Notepads

BOOKLETS

- 170** BIC® 75 mm x 75 mm Adhesive Notepad with Flag Booklet
- 168** BIC® 75 mm x 75 mm Booklet
- 169** BIC® 101 mm x 75 mm Booklet
- 171** BIC® 101 mm x 75 mm Mini Pencil Booklet
- 174** BIC® 150 mm x 150 mm Booklet Organiser
- 175** BIC® 150 mm x 150 mm Booklet with Pen Loop
- 172** BIC® Clic Stic Mini Digital Organiser
- 173** BIC® Clic Stic Mini Organiser
- 167** BIC® Flag Booklet

SCRATCH PAD

- 176** BIC® 75 mm x 127 mm Non-Adhesive Scratch Pad
- 177** BIC® 96 mm x 152 mm Non-Adhesive Scratch Pad



STICKY NOTES

BIC® Sticky Notes

BIC® STICKY NOTES

ADHESIVE NOTEPADS



50 mm x 75 mm Adhesive Notepads

EN > Ideal **pocket size** for mailing campaigns!

FR > **Taille de poche**
idéale pour les notes
d'entreprise !

ES > **¡Tamaño de bolsillo**
ideal para notas de
empresa!

DE > Ideales
Taschenformat für
Mailingkampagnen!

IT > **Dimensioni tascabili**
ideali per appunti di
lavoro!



100%

ADHESIVE NOTEPADS

BIC® STICKY NOTES

3522 / 3520

25

3552 / 3550

50

3582 / 3580

100

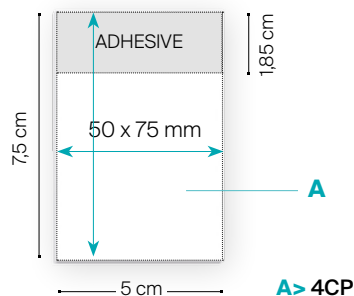

Paper type



Standard
80 g



Recycled
80 g

MOQ: 500 u.



4CP

PMS SERVICE
≥ 500 u.

3522 / 3520

1000
± 8,7 Kg

3552 / 3550

500
± 8,5 Kg

3582 / 3580

250
± 8,4 Kg



MADE IN
SPAIN



68 mm x 75 mm Adhesive Notepads

BIC® STICKY NOTES

ADHESIVE NOTEPADS

- EN** > Sticky Notes ideal to always take your messages with you!
- FR** > Bloc-notes Sticky Notes idéal pour porter vos messages toujours sur vous !
- ES** > Bloc de notas Sticky Notes ideal para llevar tus mensajes siempre contigo!
- DE** > Haftnotizen-Block: Ideal, um Ihre Nachrichten immer bei sich zu tragen!
- IT** > Blocchetto Sticky Notes ideale per portare i tuoi messaggi sempre con te!



100%



3502 / 3500

25

3532 / 3530

50

3562 / 3560

100

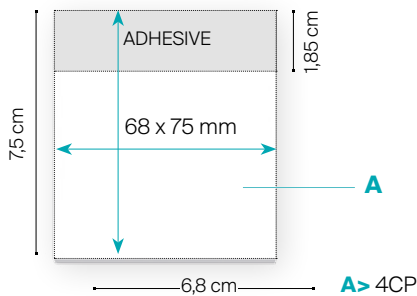

Paper type



Standard
80 g



Recycled
80 g

MOQ: 500 u. 3502 / 3500 3532 / 3530 3562 / 3560



PMS SERVICE
≥ 500 u.

500
± 5,7 Kg

250
± 5,4 Kg

130
± 5,6 Kg





75 mm x 75 mm Adhesive Notepads

- EN >** Large imprint area in a small size!
- FR >** Grande zone d'impression avec une taille mini !
- ES >** ¡Gran área de impresión en tamaño pequeño!
- DE >** Großer Druckbereich, kleines Format!
- IT >** Vasta area di stampa in piccolo formato!



ADHESIVE NOTEPADS

BIC® STICKY NOTES

3507 / 3505

25

3537 / 3535

50

3567 / 3565

100

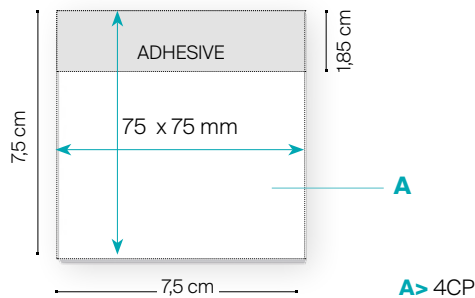

Paper type



Standard
80 g



Recycled
80 g



4CP



MOQ: 500 u.

PMS SERVICE
≥ 500 u.

3507 / 3505

500
± 6,2 Kg

3537 / 3535

250
± 5,9 Kg

3567 / 3565

130
± 6,1 Kg



*Only for 3537.



Small Adhesive Die Cut Notepads

BIC® STICKY NOTES

ADHESIVE NOTEPADS

EN > Choose from **7 stock shapes!**

Custom-made shapes available upon request

FR > Choisissez parmi les **7 formes en stock !**

Formes spéciales sur demande.

ES > ¡Escoja entre **7 formas diferentes!** Formas personalizadas disponibles bajo petición.

DE > Wählen Sie eine der **7 Standardformen.** Kundenspezifische Formen sind auf Anfrage **erhältlich.**

IT > Scegli tra le **7 forme disponibili!** Forme personalizzate **disponibili** su richiesta.



100%

3603



3607



3611

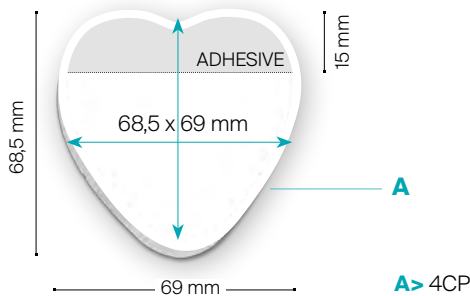

A > 4CP

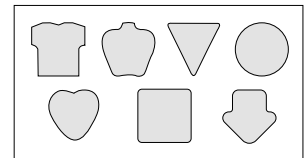

Paper type



Standard
80 g

- Size may vary depending on the chosen shape. Please contact your Customer Service Representative for further details.
- Les dimensions peuvent varier en fonction de la forme choisie. Pour de plus amples détails, veuillez contacter notre service clients.
- El tamaño puede variar según la forma elegida. Por favor, contacta con tu representante de atención al cliente para más información.
- Die Größe kann je nach der von Ihnen gewählten Form variieren. Bitte kontaktieren Sie Ihren Kundenberater für weitere Details.
- La dimensione può variare a seconda della forma scelta. Contatta il tuo rappresentante del servizio clienti per maggiori informazioni.

MOQ: 500 u. **3603** **3607** **3611**



PMS SERVICE
≥ 500 u.

500
± 6,2 Kg

250
± 6 Kg

130
± 6,2 Kg





101 mm x 75 mm Adhesive Notepads & 101 mm x 75 mm Alternating Sheet Imprint

EN > **Indispensable** in any office! **Most popular** Sticky Notes pad size! Great marketing tool! **Alternate 2 messages** for double-impact communication!

FR > **Indispensable** dans n'importe quel bureau! Le Sticky Notes **de la taille la plus populaire!** Un très bon outil de marketing! **Alternez 2 messages** pour un double impact!

ES > **¡Indispensable** en cualquier oficina! ¡El **bloc de notas** Sticky Notes **del tamaño más popular!** ¡Gran herramienta de marketing! **¡Alterna 2 mensajes** para una comunicación con doble impacto!

DE > **Unverzichtbar** in jedem Büro! Die **beliebteste Haftnotizen-Blockgröße!** Großartiges Marketinginstrument! **Mit zwei sich Seite-für-Seite abwechselnden** Botschaften erzielen Sie die doppelte Wirkung!

IT > **Indispensabile** in ogni ufficio! Lo Sticky Notes **nel formato più diffuso!** Grande strumento di marketing! **Alterna 2 messaggi** per ottenere un doppio impatto!



100%

3512



3514

3512 / 3510 / 3514 Alternating sheet
 25

3542 / 3540 / 3544 Alternating sheet
 50

3572 / 3570 / 3524 Alternating sheet
 100

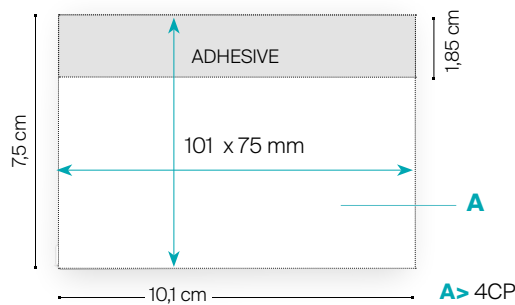

Paper type

Standard 80 g
 Recycled 80 g



PMS SERVICE
 ≥ 500 u.

MOQ: 500 u.

3512 / 3514 / 3510

500
 ± 8,2 Kg

3572 / 3570

130
 ± 8,3 Kg

MOQ: 250 u.

3542 / 3544 / 3524 / 3540

250
 ± 8 Kg



ADHESIVE NOTEPADS

BIC® STICKY NOTES



Medium Adhesive Die Cut Notepads

BIC® STICKY NOTES

ADHESIVE NOTEPADS

- EN >** Choose from **28 stock shapes!**
Custom-made shapes also **available** upon request.
- FR >** Choisissez parmi les **28 formes en stock ! Formes spéciales** sur demande.
- ES >** ¡Escoge entre **28 formas diferentes!**
Formas personalizadas también disponibles bajo petición.
- DE >** Wählen Sie eine der **28 Standardformen.** Kundenspezifische Formen sind auf Anfrage **erhältlich.**
- IT >** Scegli tra le oltre **28 forme!**
Forme personalizzate disponibili su richiesta.



3604 / 3602

25

3608 / 3606

50

3612 / 3610

100

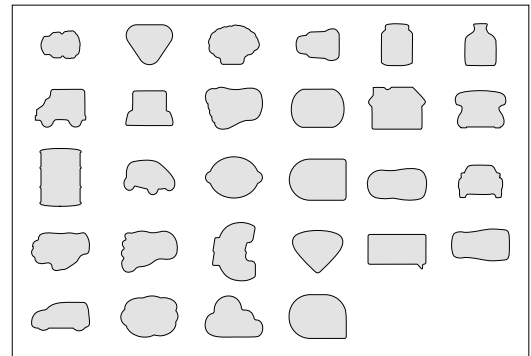
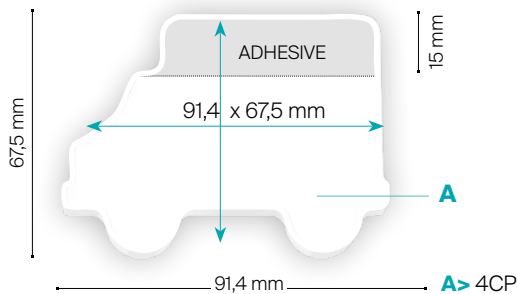

Paper type



Standard
80 g



Recycled
80 g

- Size may vary depending on the chosen shape. Please contact your Customer Service Representative for further details.
- Les dimensions peuvent varier en fonction de la forme choisie. Pour de plus amples détails, veuillez contacter notre service clients.
- El tamaño puede variar según la forma elegida. Por favor, contacta con tu representante de atención al cliente para más información.
- Die Größe kann je nach der von Ihnen gewählten Form variieren. Bitte kontaktieren Sie Ihren Kundenberater für weitere Details.
- La dimensione può variare a seconda della forma scelta. Contatta il tuo rappresentante del servizio clienti per maggiori informazioni.

MOQ: 500 u.



PMS SERVICE
≥500 u.

3604 / 3608 / 3612 /
3602 3606 3610

400
± 6,6 Kg

200
± 6,4 Kg

100
± 6,4 Kg





101 mm x 101 mm Adhesive Notepads

EN > Stand out from the crowd with this **original squared shape!**

FR > Démarquez-vous des autres avec cette **originale forme carrée!**

ES > ¡Destaca sobre los demás con esta **original forma cuadrada!**

DE > Heben Sie sich mit dieser originellen **quadratischen Form von der Masse ab!**

IT > Spicca tra tutti per la sua **originale forma quadrata!**



100%



70%

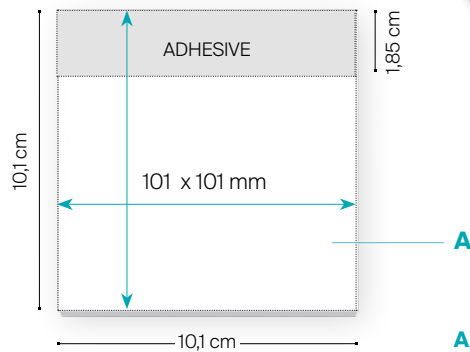

A > 4CP

3518 / 3516
25

3548 / 3546
50

3578 / 3576
100

Paper type

Standard 80 g Recycled 80 g

MOQ: 500 u.

4CP

PMS SERVICE
≥ 500 u.

3518 / 3516
400
+ 95 Kg

3548 / 3546
200
+ 91 Kg

3578 / 3576
100
+ 8,7 Kg



ADHESIVE NOTEPADS

BIC® STICKY NOTES



101 mm x 152 mm Adhesive Notepads

EN > Large imprint area for big messages!
Don't miss anything!

FR > Grande surface d'impression pour
de grands messages!
Pour que rien ne vous échappe !

ES > ¡Gran área de impresión para grandes
mensajes! ¡No te olvides de nada!

DE > Große Druckfläche für großartige
Nachrichten! Halten Sie alle Gedanken
fest!

IT > Ampia area di stampa per grandi
messaggi! Non perderti nulla!



90%

BIC® STICKY NOTES

ADHESIVE NOTEPADS

3517 / 3515

25

3547 / 3545

50

3577 / 3575

100

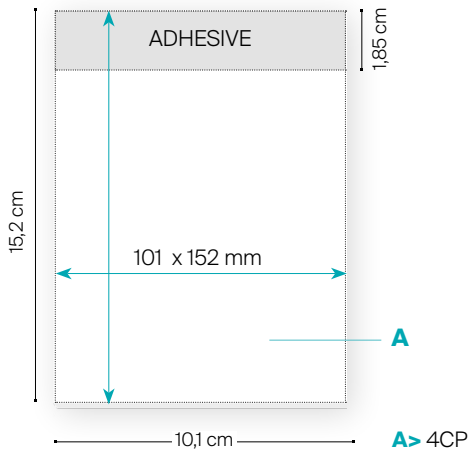

Paper type



Standard
80 g



Recycled
80 g

MOQ: 500 u.



PMS SERVICE
≥500 u.

3517 /
3515

250
± 8,5 Kg

3547 /
3545

125
± 8,2 Kg

3577 /
3575

65
± 8,3 Kg





Sticky Notes Ecolutions®

- EN >** All BIC® Sticky Notes Ecolutions® products are made of paper stock containing 100% recycled fibre and water-based adhesive. The percentage is calculated based on paper stock.
- FR >** Tous les produits BIC® Sticky Notes Ecolutions® sont fabriqués avec du papier contenant 100 % de fibres recyclées et un adhésif à base d'eau. Le pourcentage de matériel recyclé est calculé sur le total de la bobine de papier.
- ES >** Todos los productos BIC® Sticky Notes Ecolutions® están hechos con papel de fibra 100% reciclada y adhesivo a base de agua. El porcentaje de material reciclado está calculado sobre el total de la bobina de papel.
- DE >** Alle BIC® Sticky Notes Ecolutions® Produkte werden aus 100% Recyclingpapier-Fasern mit einem Kleber auf Wasserbasis hergestellt. Der Prozentanteil wird auf Basis der Papiermenge berechnet.
- IT >** Tutti i prodotti BIC® Sticky Notes Ecolutions® sono prodotti con carta contenente il 100% di fibra riciclata e colla a base d'acqua. Effetto riciclato naturale. La percentuale di materiale riciclato è calcolata sul totale della bobina di carta.



ADHESIVE NOTEPADS

BIC® STICKY NOTES



If you want more information about our BIC® Ecolutions® & how it's made visit: bicgraphic.eu/ie/sustainable-development.html.

Products available with recycled paper:

- BIC® 50 mm x 75 mm Adhesive Notepads Ecolutions®Pg 157
- BIC® 68 mm x 75 mm Adhesive Notepads Ecolutions®Pg 158
- BIC® 75 mm x 75 mm Adhesive Notepads Ecolutions®Pg 159
- BIC® 101 mm x 75 mm Adhesive Notepads Ecolutions®Pg 161
- BIC® 101 mm x 101 mm Adhesive Notepads Ecolutions®Pg 163
- BIC® 101 mm x 152 mm Adhesive Notepads Ecolutions®Pg 164
- BIC® Medium Adhesive Die Cut Notepads Ecolutions®Pg 162



Add the "Mobius loop" to your artwork at no additional charge! Next to the mobius loop, it is required to include the text "Recycled Paper". (Mobius loop imprint defaults to lower left hand corner of your notepad unless otherwise specified).



Booklets

BIC® STICKY NOTES

BOOKLETS



Flag Booklet

- EN >** The most desired office item! Play with your logo in a vertical or horizontal position!
- FR >** L'article de bureau le plus convoité ! Jouez avec votre logo en position verticale ou horizontale !
- ES >** ¡El elemento de oficina más deseado! ¡Juega con tu logo en posición vertical o horizontal!
- DE >** Der begehrteste Büroartikel! Spielen Sie mit Ihrem Logo in vertikaler oder horizontaler Position!
- IT >** Il più desiderato in ufficio! Gioca con il tuo logo in posizione orizzontale o verticale!



BOOKLETS
BIC® STICKY NOTES

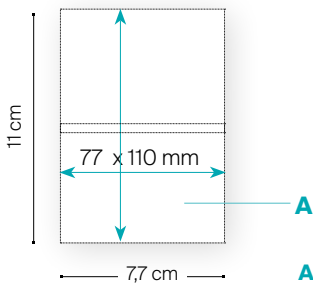

A > 4CP

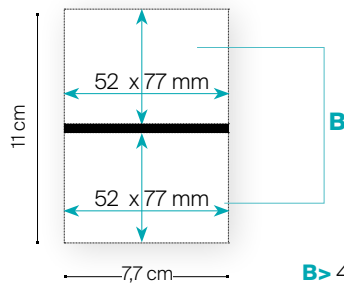

B > 4CP

3730
25

- 125 Mylar flags, 25 of each colour
- 125 index repositionnables, 25 de chaque couleur
- 125 Mylar flags, 25 de cada color
- 125 Haftstreifen aus Polyesterfilm, je 25 in jeder der 5 Farben
- 125 segnapagina totali, 25 per colore

- Pattern and matt soft-feel finishes available in all BIC® Booklets under request



MOQ: 250 u.

150
± 156 Kg





75 mm x 75 mm Booklet

BIC® STICKY NOTES

BOOKLETS

EN > Double the impact of your message with a fully personalised cover and Sticky Notes pad.

FR > Double impact de votre message grâce à la couverture personnalisée et au bloc-notes Sticky Notes.

ES > Doble impacto para tu mensaje gracias a su cubierta personalizada y su bloc de notas Sticky Notes.

DE > Doppelte Wirkung für Ihre Marke dank vollständig personalisierter Deckseite und Haftnotizenblock.

IT > Un doppio impatto per il tuo messaggio con la copertina e il blocco Sticky Notes personalizzati.

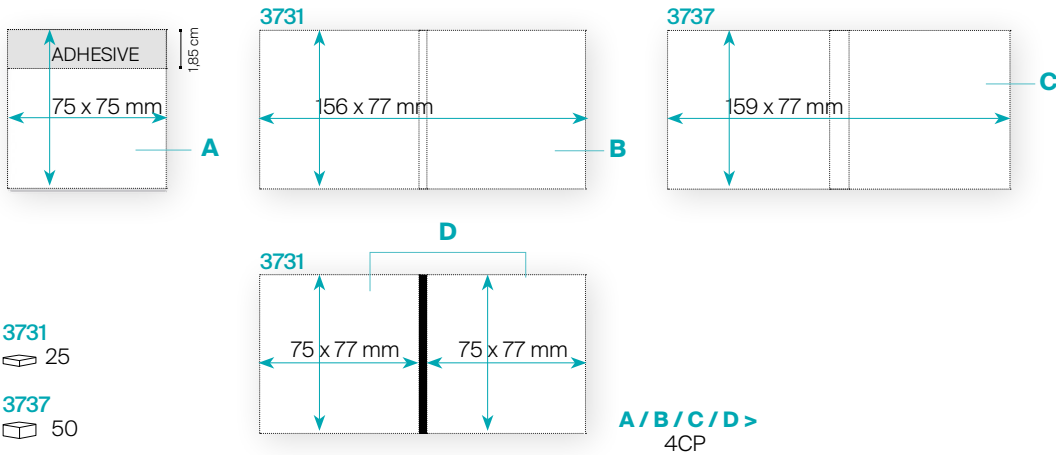

Paper type



- Pattern and matt soft-feel finishes available in all BIC® Booklets under request



MOQ: 250 u. with unimprinted pad
MOQ: 500 u. with imprinted pad

3731 500 ±7,8 Kg
3737 250 ±7,3 Kg





101 mm x 75 mm Booklet

EN > Double the impact of your message with a fully personalised cover and Sticky Notes pad in the most popular size.

FR > Double impact de votre message grâce à la couverture personnalisée et au bloc-notes Sticky Notes dans sa taille la plus populaire.

ES > Doble impacto para tu mensaje gracias a su cubierta personalizada y su bloc de notas Sticky Notes en su tamaño más popular.

DE > Doppelte Wirkung für Ihre Marke dank vollständig personalisierter Deckseite und Haftnotizenblock im beliebtesten Format.

IT > Un doppio impatto per il tuo messaggio con la copertina e il blocco Sticky Notes, nel formato più diffuso, personalizzati.



BOOKLETS

BIC® STICKY NOTES

Matt soft-feel laminated finish

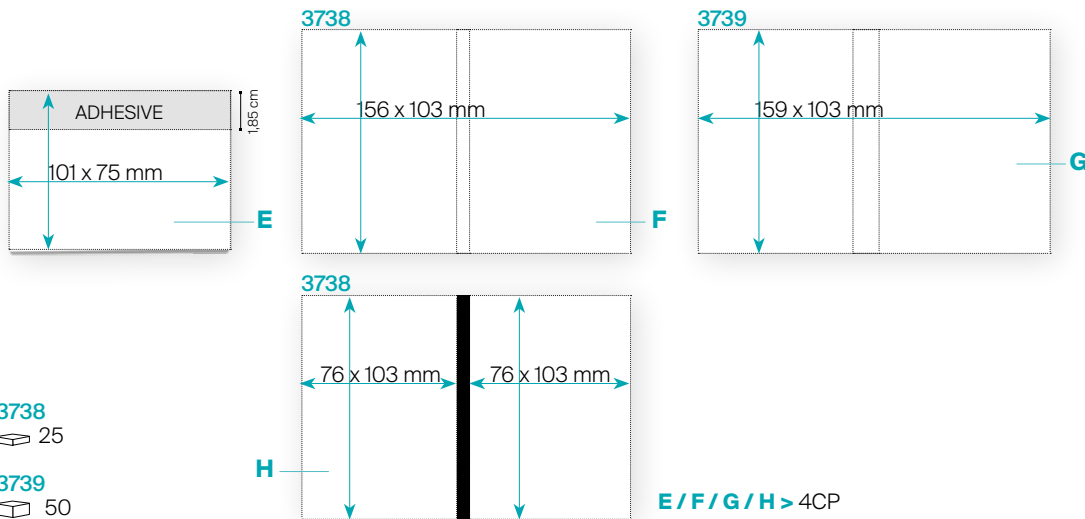

3738
25

3739
50

Paper type



Standard
80 g

- Pattern and matt soft-feel finishes available in all BIC® Booklets under request



MOQ: 250 u.
with unimprinted pad

MOQ: 500 u.
with imprinted pad

3738
500
+59 Kg

MOQ: 250 u.
with imprinted pad

3739
250
+51 Kg





75 mm x 75 mm Adhesive Notepad with Flag Booklet

BIC® STICKY NOTES

BOOKLETS

EN > The **multi-purpose** notes tool.

FR > Le **multifunction** pour la prise de notes.

ES > ¡El bloc de notas **multiuso!**

DE > Das **Multitool** für Ihre Notizen.

IT > Il blocchetto **multi funzione!**

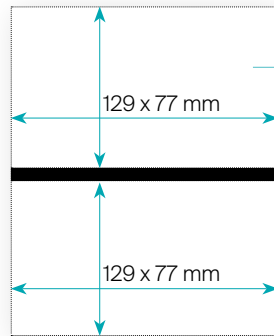
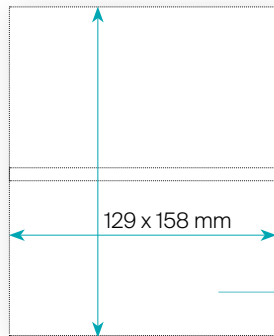
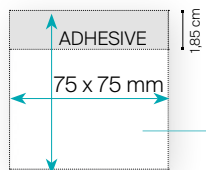

C A / B / C > 4CP

3732
25

Paper type

Standard
80 g

- 125 Mylar flags, 25 of each colour
- 125 index repositionnables, 25 de chaque couleur
- 125 Mylar flags, 25 de cada color
- 125 Haftstreifen aus Polyesterfilm, je 25 in jeder der 5 Farben
- 125 segnapagina totali, 25 per colore

- Pattern and matt soft-feel finishes available in all BIC® Booklets under request



MOQ: 250 u.
with unimprinted pad

MOQ: 500 u.
with imprinted pad

3732

200
± 5.2 Kg





101 mm x 75 mm Mini Pencil Booklet

EN > This great office **set includes BIC® Matic® Mini pencil.**
Always ready to take your notes!

FR > Ce superbe **set de bureau comprend le porte-mine BIC® Matic® Mini.** Toujours prêt pour prendre des notes !

ES > Este fantástico **set de oficina incluye el lápiz BIC® Matic® Mini.** ¡Siempre a punto para tomar tus notas!

DE > Dieses tolle Büroset **beinhaltet den BIC® Matic® Mini-Bleistift.** Allzeit bereit für Ihre Notizen!

IT > Questo fantastico **set per ufficio include il portamine BIC® Matic® Mini.** Sempre pronto a prendere appunti!

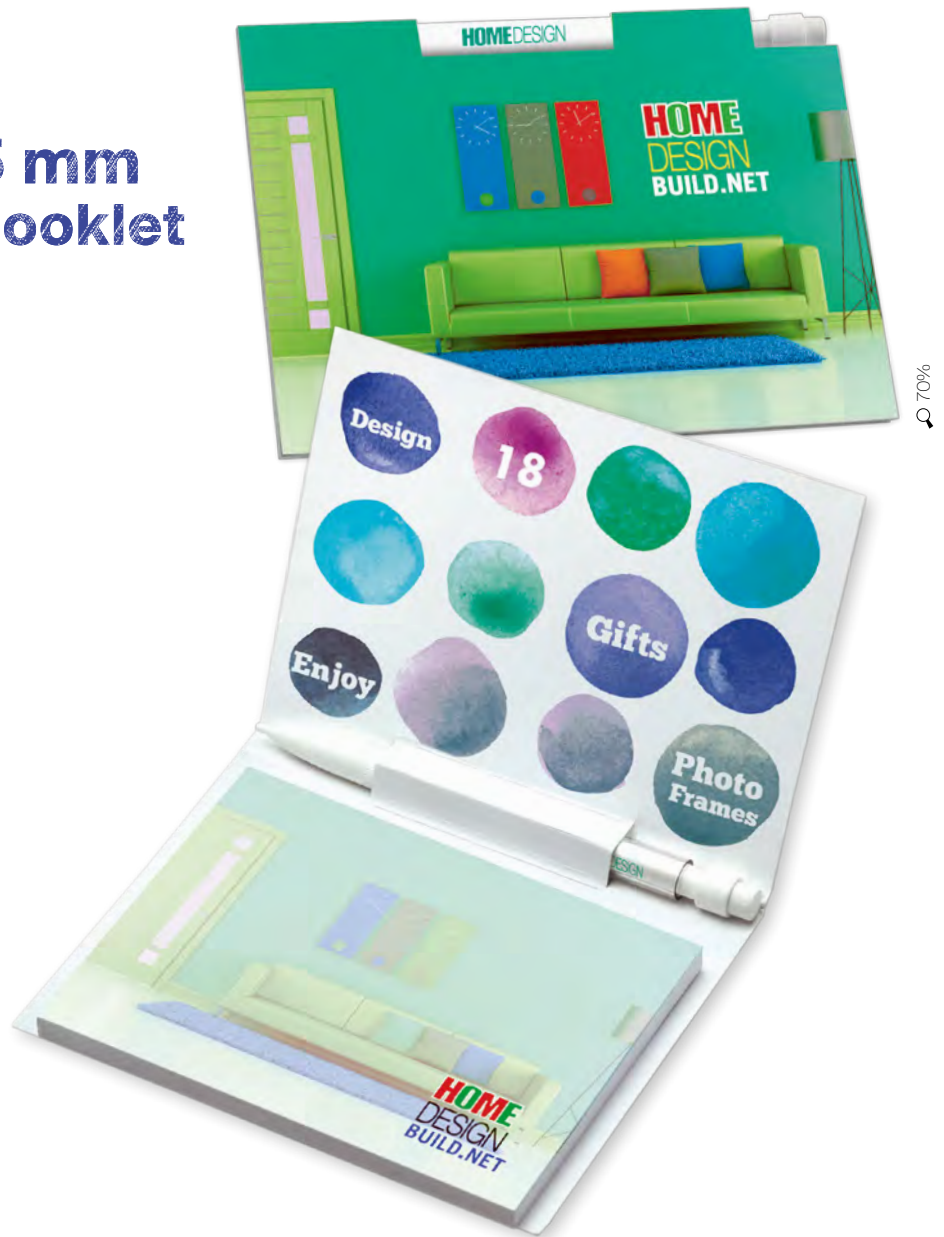

70%

BOOKLETS
BIC® STICKY NOTES

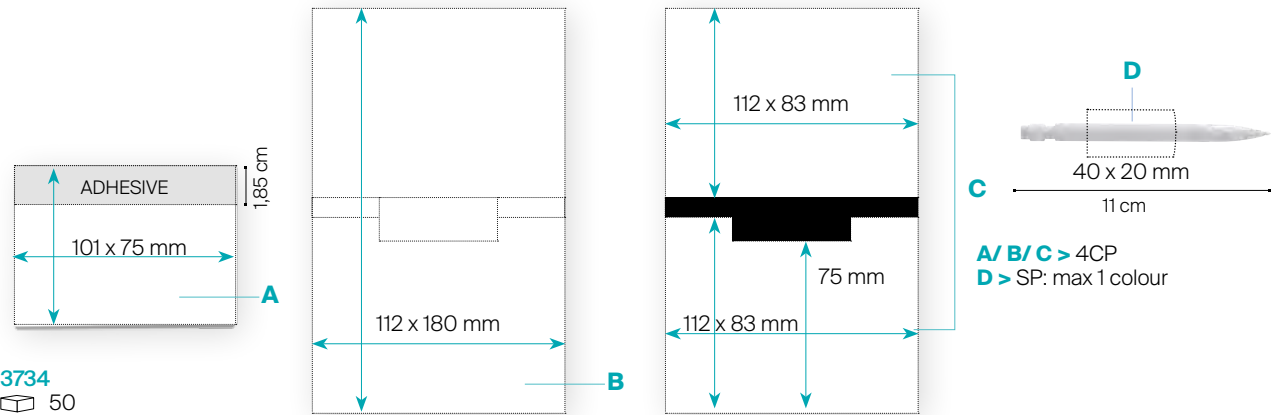

Paper type



Standard
80 g

• Pattern and matt soft-feel finishes available in all BIC® Booklets under request



MOQ: 250 u.



± 5,2 Kg





Clic Stic Mini Organiser

EN > Use this all-in-one organiser for meeting and daily notes. **Includes BIC® Clic Stic Mini pen.**

FR > Utilisez ce set de rangement tout en un pour vos réunions et vos notes quotidiennes. **Stylo BIC® Clic Stic Mini inclus.**

ES > Usa este organizador todo en uno para reuniones y notas de cada día. **Bolígrafo BIC® Clic Stic Mini incluido.**

DE > Verwenden Sie diesen All-in-One-Organizer für Meetings oder Ihre alltäglichen Notizen. **Mit BIC® Clic Stic Mini-Kugelschreiber.**

IT > Utilizza questo organizer tutto in uno per riunioni e appunti quotidiani. **Include la penna BIC® Clic Stic Mini.**



60%



3733

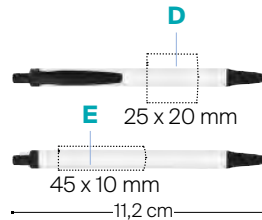
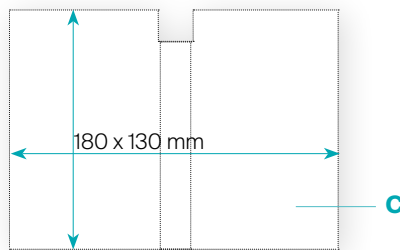
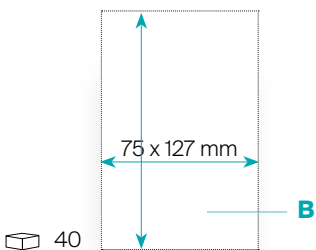
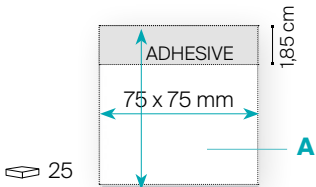

- 125 Mylar flags, 25 of each colour
- 125 index repositionnables, 25 de chaque couleur
- 125 Mylar flags, 25 de cada color
- 125 Haftstreifen aus Polyesterfilm, je 25 in jeder der 5 Farben
- 125 segnapagina totali, 25 per colore

A / B / C > 4CP
D / E > SP: max 1 colour

Paper type



Barrel



MIX & MATCH

BIC® Clic Stic Mini
Clip and Section
OPAQUE



FROSTED



BARREL



MOQ: 250 u. with unimprinted pad
MOQ: 500 u. with imprinted pad



±7 Kg



- Pattern and matt soft-feel finishes available in all BIC® Booklets under request



Clic Stic Mini Digital Organiser

EN > Photographic image all around! This exceptional communication tool **includes BIC® Clic Stic Mini Digital pen.**

FR > Image photographique de toutes parts ! Cet article exceptionnel de communication **comprend un stylo BIC® Clic Stic Mini Digital.**

ES > ¡Imagen fotográfica en todas partes! Este excepcional artículo de comunicación **incluye el bolígrafo BIC® Clic Stic Mini Digital.**

DE > Photo-Image auf allen Seiten! Dieses außergewöhnliche Kommunikations-Tool **beinhaltet den BIC® Clic Stic Mini-Digitalkugelschreiber.**

IT > Immagine fotografica dappertutto! Questo eccezionale strumento di comunicazione **include la penna BIC® Clic Stic Mini Digital.**



BOOKLETS

BIC® STICKY NOTES

3735

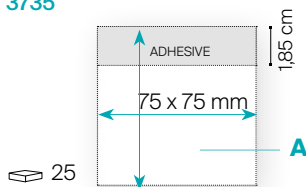

- 125 Mylar flags, 25 of each colour
- 125 index repositionnables, 25 de chaque couleur
- 125 Mylar flags, 25 de cada color
- 125 Haftstreifen aus Polyesterfilm, je 25 in jeder der 5 Farben
- 125 segnapagina totali, 25 per colore

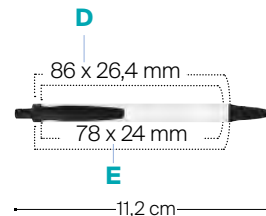
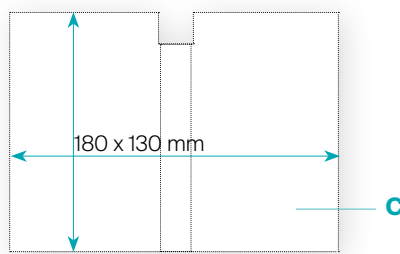
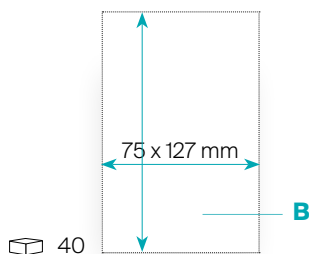

A/B/C > 4CP
D/E > SP: max 1 colour

Paper type
Standard
80 g

Barrel
OPAQUE
01

MIX & MATCH

BIC® Clic Stic Mini
Clip and Section
OPAQUE

- 01 02 03 04
- 05 07 10 12
- 18 20

FROSTED

- 40 63 66
- 67 68 69
- 71

BARREL

- 01

4CP

MOQ: 250 u. with unprinted pad
MOQ: 500 u. with imprinted pad

125
+7 Kg

MADE IN SPAIN

- Pattern and matt soft-feel finishes available in all BIC® Booklets under request



150 mm x 150 mm Booklet Organiser

BIC® STICKY NOTES

BOOKLETS

- EN >** Create a unique note pad with this **original square shape!**
- FR >** Créez un carnet de notes unique avec une **forme originale !**
- ES >** ¡Crea una libreta única de una **original forma cuadrada!**
- DE >** Kreieren Sie einen einzigartigen Notizblock in dieser **originellen quadratischen Form!**
- IT >** Crea un blocchetto unico con la sua **originale forma quadrata!**

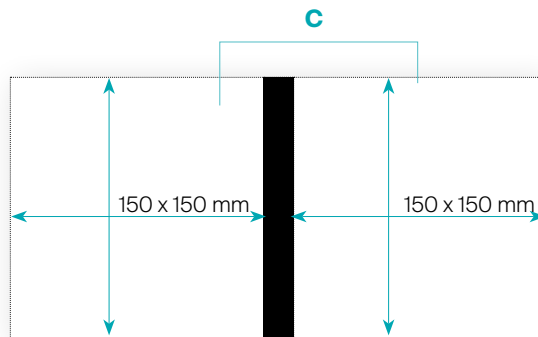
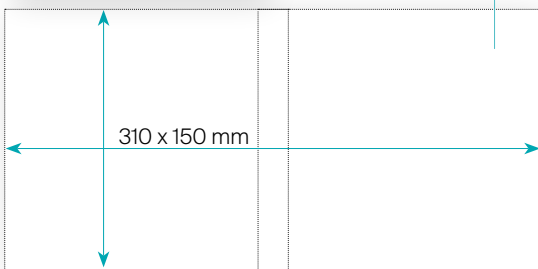
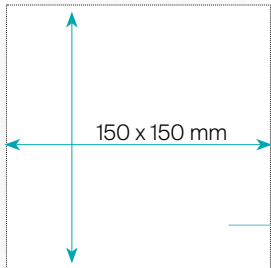

3745

100

A/B/C > 4CP

Paper type



Standard
60 g

- Pattern and matt soft-feel finishes available in all BIC® Booklets under request



MOQ: 500 u.

40
± 64 Kg





150 mm x 150 mm Booklet with Pen Loop

EN > Make your notes stand out using this **original format**. Suggested presentation with BIC® Wide Body™ Digital. **Combine this item with any of our writing products.**

FR > Mettez vos notes en relief grâce à ce **format original**. Suggestion de présentation avec le BIC® Wide Body™ Digital. **Combinez cet article avec n'importe quel produit d'écriture.**

ES > Destaque sus notas con este **original formato**. Sugerencia de presentación con BIC® Wide Body™ Digital. **Combine este artículo con cualquiera de nuestros productos de escritura.**

DE > Heben Sie Ihre Notizen mit diesem **klassischen Format hervor**. Ideal kombiniert mit BIC® Wide Body™ Digital. **Kombinieren Sie diesen Artikel mit einem unserer Schreibgeräte.**

IT > Prendi i tuoi appunti utilizzando questo **formato originale**. **Abbina questo prodotto con uno dei nostri articoli da scrittura.** Prodotto consigliato. BIC® Wide Body™ Digital.

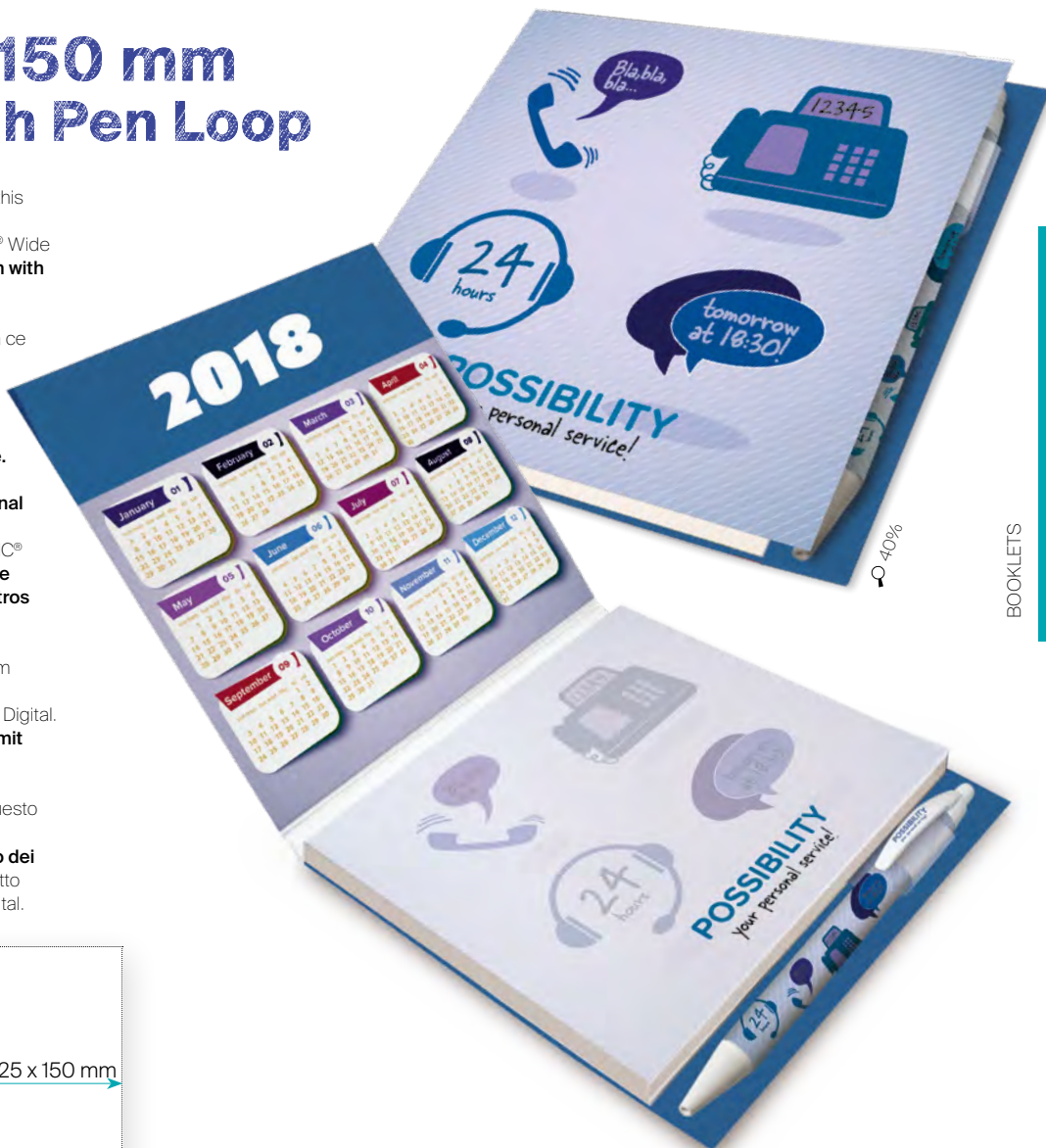

40%

BOOKLETS

BIC® STICKY NOTES

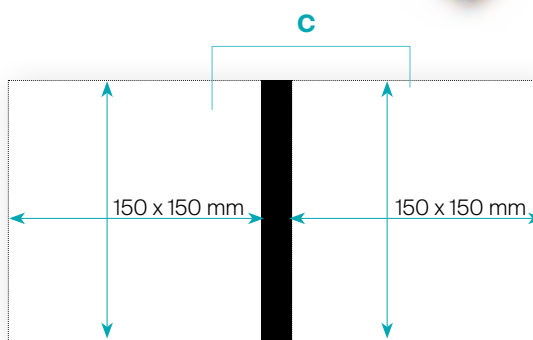
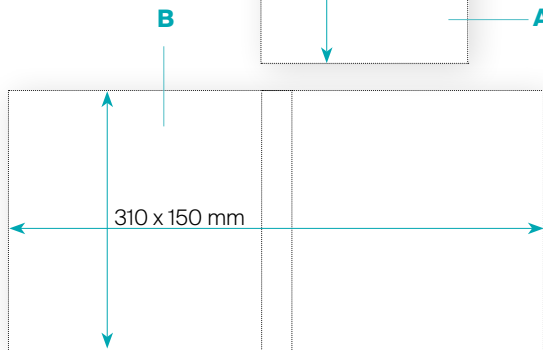
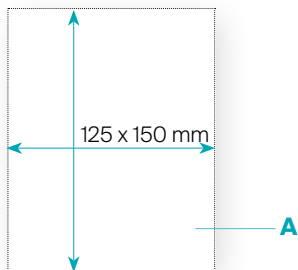

3746

100

A/B/C > 4CP

Paper type



Standard 60 g

- Pen not included
- Stylo non inclus
- Bolígrafo no incluido
- Ohne Kugelschreiber
- Penna non inclusa.

- Pattern and matt soft-feel finishes available in all BIC® Booklets under request



MOQ: 500 u.



± 6,7 Kg





75 mm x 127 mm Non-Adhesive Scratch Pad

BIC® STICKY NOTES

SCRATCH PAD

- EN > Indispensable scratch pad** for lists and quick notes.
- FR > L'outil indispensable** pour vos notes et mémos.
- ES > Bloc de notas indispensable** para hacer listas y tomar notas rápidas.
- DE > Unverzichtbarer Notizblock** für Listen und schnelle Notizen.
- IT > Blocco note indispensabile** per fare liste e prendere appunti veloci.



70%

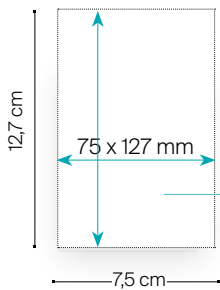

A

A > 4CP

3760
 20
 3761
 40

Paper type



Standard
60 g



MOQ: 500 u.

3760

3761

400

200

± 5,4
Kg

± 5,2
Kg





96 mm x 152 mm Non-Adhesive Scratch Pad

EN > Indispensable scratch pad for lists and quick notes.

FR > L'outil indispensable pour vos notes et mémos.

ES > Bloc de notas indispensable para hacer listas y tomar notas rápidas.

DE > Unverzichtbarer Notizblock für Listen und schnelle Notizen.

IT > Blocco note indispensabile per fare liste e prendere appunti veloci.



SCRATCH PAD

BIC® STICKY NOTES

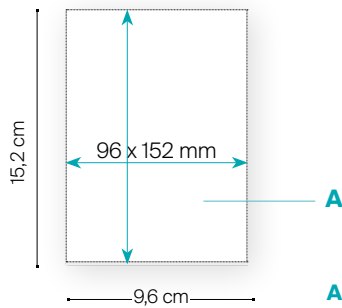

3762
20
3763
40

A > 4CP

Paper type

Standard
60 g



MOQ: 500 u.

3762

350
± 8,6
Kg

3763

200
± 8 Kg



PU COVER NOTEBOOKS

181 BIC® Notebooks Dual A5

181 BIC® Notebooks Dual A6

PLASTIC COVER NOTEBOOKS

182 BIC® Notebooks Plastic Cover

183 BIC® Notebooks Plastic Cover *britePix™*

CHIPBOARD COVER NOTEBOOKS

184 BIC® Notebooks Chipboard Cover

185 BIC® Notebooks Chipboard Cover *britePix™*

OFFICE ACCESSORIES

188 Classic Mug

189 Laser Mug

187 Mouse Pad

188 Sublimation Mug



NOTEBOOKS



Notebooks

BIC® NOTEBOOKS

PU COVER NOTEBOOKS

Dual A5 & A6

EN > Stand out from the crowd with this personalisable notebook! **Create the product you need for each event by combining the PU cover colour with the stack of paper inside.**

FR > Démarquez-vous de la concurrence grâce à ce carnet de notes personnalisable ! **Créez le produit dont vous avez besoin pour chaque événement en combinant la couleur de la couverture en PU et celle des feuilles à l'intérieur.**

ES > ¡Destaca entre la multitud con esta libreta personalizable! **Crea el producto que necesitas para cada evento combinando el color de la portada en PU con el bloc de hojas de su interior.**

DE > Heben Sie sich von der Masse ab mit diesem personalisierbaren Notizbuch! **Kreieren Sie das Produkt, das Sie für Ihre Events benötigen, indem Sie die PU-Coverfarbe mit der Farbe des Papiers kombinieren.**

IT > Fatti notare con questo blocco note personalizzabile! **Crea il prodotto di cui hai bisogno per ogni evento combinando il colore della copertina in PU con la carta al suo interno.**

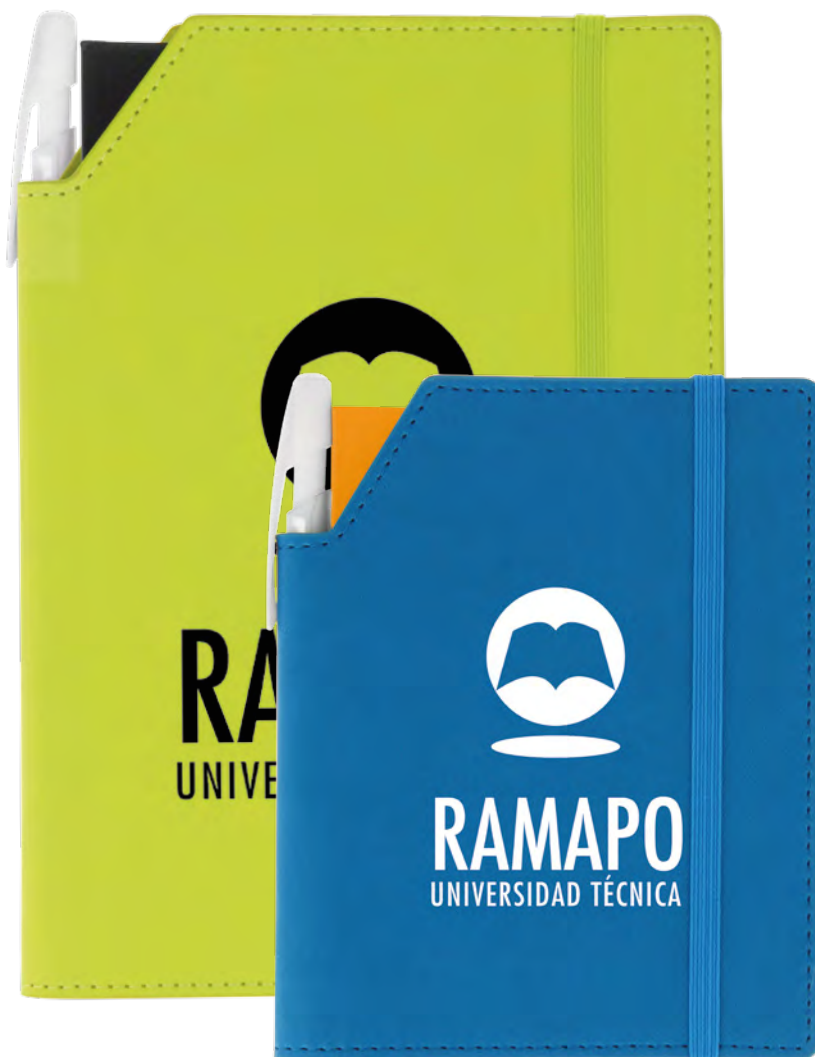

PU COVER NOTEBOOKS

BIC® NOTEBOOKS

60%

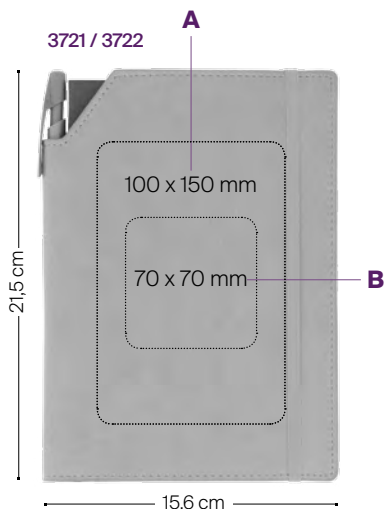

3721 / 3722
A5

3725 / 3726
A6

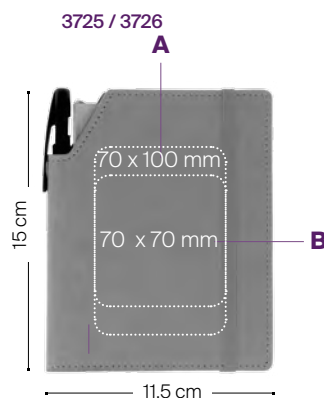

Need a new inner notepad?
Find them on our price list:

A5: 3724 / 3728 / 3729
A6: 3712 / 3713 / 3714



A > SP: max. 1 colour
B > DB/HS: max. 1 colour

Cover

Stack of paper

3721/3722

3725/3726



80 g



80 g

- Plain or lined paper
- Papier uni ou ligné
- Papel blanco o a rayas
- Blanko- oder Liniertes Papier
- Carta con o senza righe

- Pen not included
- Stylo non inclus
- Bolígrafo no incluido
- Ohne Kugelschreiber
- Penna non inclusa

MOQ: 50 u.

3721/ 3725/
3722 3726
30 40
±75 Kg ±4,5 Kg

BIC® Notebooks

Plastic Cover

BIC® NOTEBOOKS

PLASTIC COVER NOTEBOOKS

- EN >** Transparent plastic cover notebook with a sturdy elastic loop for any pen size.
- FR >** Cahier à spirales avec couverture plastique transparente et boucle élastique adaptée à tous les types de stylos.
- ES >** Cuaderno con tapa de plástico transparente y cinta elástica para cualquier tamaño de bolígrafo.
- DE >** Notizbuch mit transparentem Kunststoffeinband und elastischer Schlaufe für Kugelschreiber jeder Größe.
- IT >** Quaderno con copertina di plastica trasparente con portapenna elastico per qualsiasi dimensione di penna.



3701
Large
Grand
Grande
Groß
Grande

3700
Small
Petit
Pequeño
Klein
Piccolo



A > SP: max. 4 colours
B > SP: max. 4 colours

51

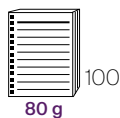

- Pen not included
- Stylo non inclus
- Bolígrafo no incluido
- Ohne Kugelschreiber
- Penna non inclusa

MOQ: 50 u.

Model	Weight
3701	15 ± 7,5 Kg
3700	25 ± 5,5 Kg

Notebooks Plastic Cover

britePix™

- EN >** Maximize the impact of your promotional gift with this **full-colour print notebook!**
- FR >** Optimisez l'impact de votre cadeau promotionnel avec ce **carnet de notes à impression quadri!**
- ES >** ¡Maximiza el impacto de tu regalo promocional con esta **libreta con impresión a todo color!**
- DE >** Maximieren Sie die Wirkung Ihres Werbegeschenks mit diesem **Notizbuch im Vollfarbdruck!**
- IT >** Massimizza l'impatto del tuo regalo promozionale con questo **blocco per appunti con stampa full-colour.**

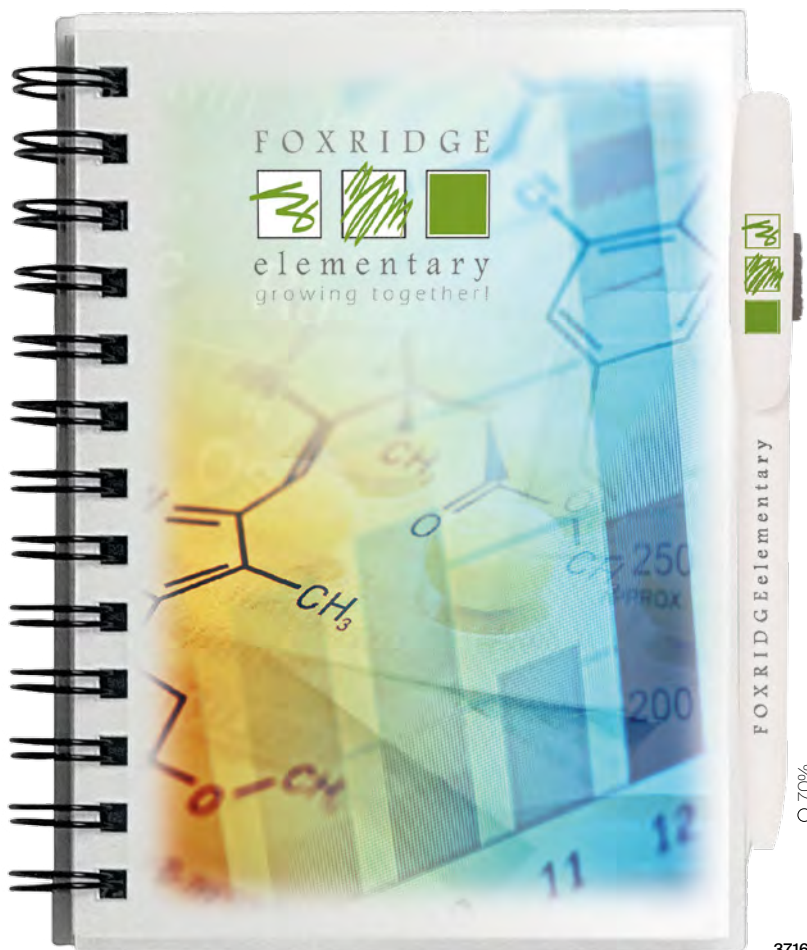

3716

PLASTIC COVER NOTEBOOKS

BIC® NOTEBOOKS

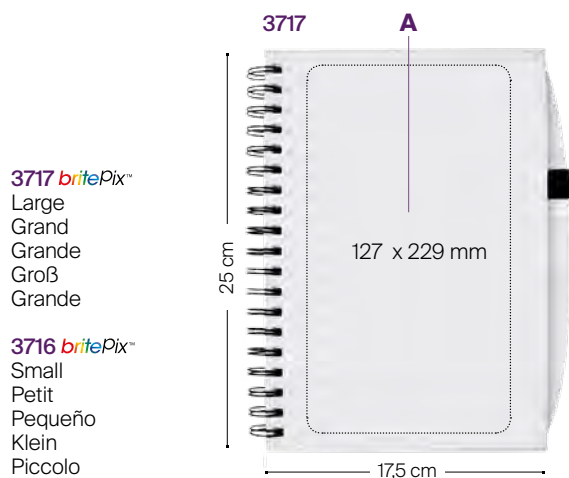

3717 britePix™
Large
Grand
Grande
Groß
Grande

3716 britePix™
Small
Petit
Pequeño
Klein
Piccolo



A > BP: full-colour
B > BP: full-colour

51

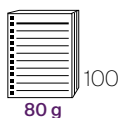

- Pen not included
- Stylo non inclus
- Bolígrafo no incluido
- Ohne Kugelschreiber
- Penna non inclusa



	3717	3716
	15	25
MOQ: 50 u.	±78 Kg	±65 Kg

BIC® Notebooks Chipboard Cover

BIC® NOTEBOOKS

CHIPBOARD COVER NOTEBOOKS

EN > Ideal combination with BIC® Writing Instrument. **High-impact results in hot-stamping.**

FR > Combinaison idéale avec l'instrument d'écriture BIC®. **Un résultat impressionnant avec estampage à chaud.**

ES > Combinación ideal con un instrumento de escritura BIC®. **Impactante resultado en termograbado.**

DE > Ideal mit einem BIC®-Schreibgerät zu kombinieren. **Beeindruckende Ergebnisse mit Heißprägung.**

IT > Combinazione ideale con gli strumenti di scrittura BIC®. **Risultato d'impatto con stampa a caldo.**

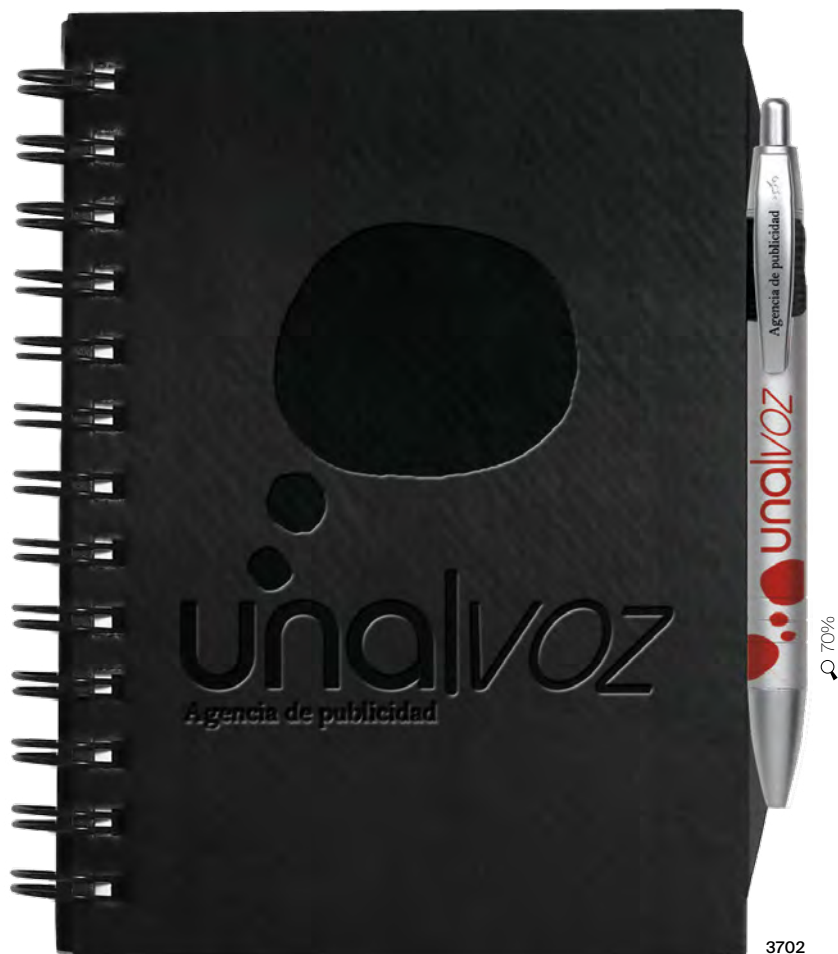

3702

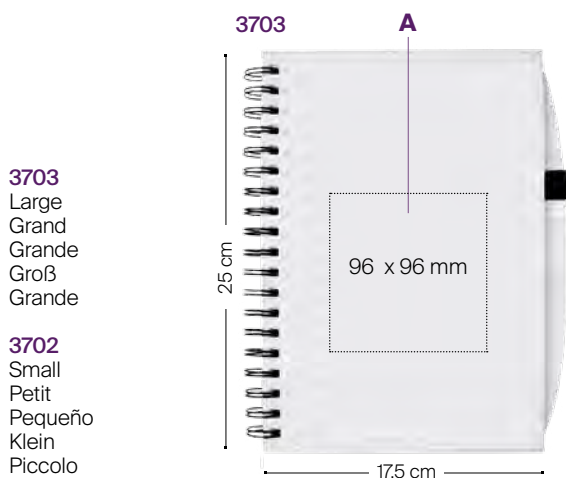

3703
Large
Grand
Grande
Groß
Grande

3702
Small
Petit
Pequeño
Klein
Piccolo

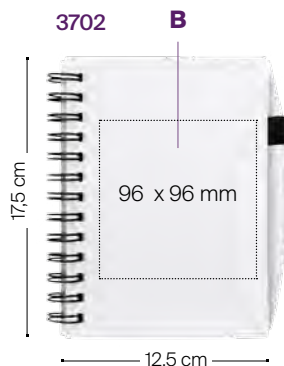

A/B > HS: max. 1 colour

02

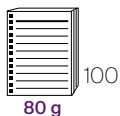

- Pen not included
- Stylo non inclus
- Bolígrafo no incluido
- Ohne Kugelschreiber
- Penna non inclusa

3703 3702
MOQ: 50 u. 15 25
± 7,5 Kg ± 5,5Kg

Notebooks

Chipboard Cover

britePix™

- EN >** Choose a black or white cover for best impact of your photographic logo!
- FR >** Choisissez la couverture noire ou blanche, pour un meilleur impact photographique de votre logo !
- ES >** Elige tu tapa en color negro o blanco para un mejor impacto fotográfico de tu logo!
- DE >** Wählen Sie das schwarze oder das weiße Cover für die beste fotografische Wirkung Ihres Logos!
- IT >** Massimizza l'impatto del tuo regalo promozionale con questo blocco per appunti con stampa full-colour.



CHIPBOARD COVER NOTEBOOKS

BIC® NOTEBOOKS

70%

3718

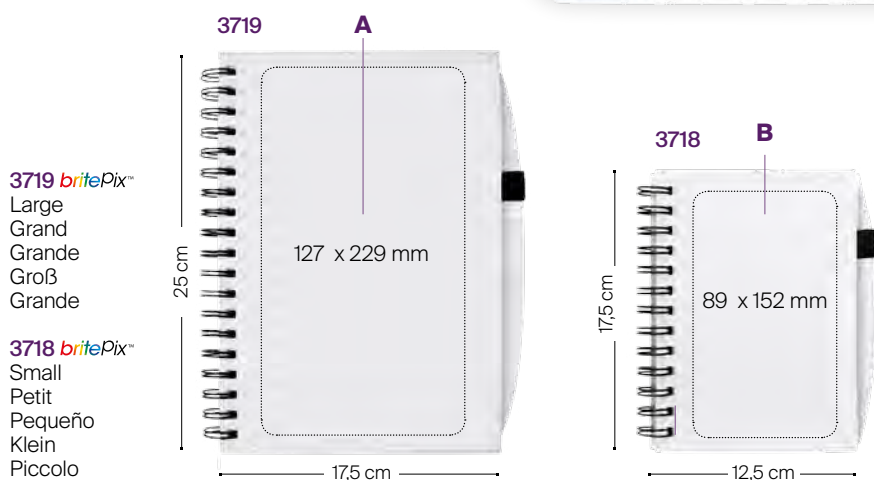

3719 *britePix™*
Large
Grand
Grande
Groß
Grande

3718 *britePix™*
Small
Petit
Pequeño
Klein
Piccolo

A > BP: full-colour

01 02

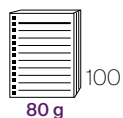

- Pen not included
- Stylo non inclus
- Bolígrafo no incluido
- Ohne Kugelschreiber
- Penna non inclusa



3719 **3718**
MOQ: 50 u. 15 25
+ 8 Kg + 68 Kg

Office Accessories

OFFICE ACCESSORIES

Mouse Pad

- EN >** This ideal mouse pad for daily use at home or work is made of **high-quality microfibre cloth and a rubberised base.**
- FR >** Tapis de souris idéal pour une utilisation quotidienne, au travail ou à la maison. Fabriqué avec un tissu en **microfibre de grande qualité et une base en caoutchouc.**
- ES >** Alfombrilla para ratón ideal para el uso diario, en el trabajo o el hogar. Hecha de **tela de microfibra de alta calidad y con base de goma.**
- DE >** Das ideale Mousepad für den täglichen Einsatz zu Hause oder am Arbeitsplatz. **Aus qualitativ hochwertiger Mikrofaser mit gummierter Unterseite.**
- IT >** Questo tappetino per mouse, ideale per l'uso quotidiano a casa o al lavoro, è composto da una superficie in **microfibra di alta qualità su uno strato di gomma.**

High definition
 long-lasting results



MOUSE PAD

OFFICE ACCESSORIES

15031
 25%

A

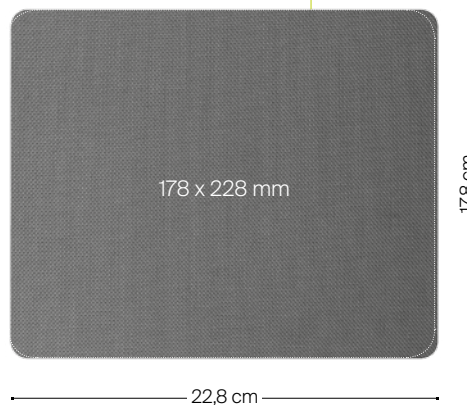

15031

A> SU: 4-colour process



- FR >** Résultats durables haute définition
- ES >** Resultados duraderos y de alta definición
- DE >** Hochauflösender, langlebiger Druck
- IT >** Risultati duraturi ad alta definizione

15031

MOQ: 50 u. ±9 Kg

01

Classic Mug & Sublimation Mug



3835

EN > Ceramic mug that features glossy finish both inside and outside.
Large C-shaped handle.

FR > Mug en céramique avec une finition satinée, extérieur et intérieur.
Large anse en forme de C.

ES > Taza de cerámica con acabado brillante tanto dentro como fuera.
Mango grande con forma de C.

DE > Keramikbecher mit Glanzoberfläche an der Innen- und Außenseite.
Großer C-Henkel.

IT > Tazza in ceramica con finitura lucida all'interno e all'esterno.
Grande manico a mezzaluna.



3835

3837

EN > Ceramic mug prepared for sublimation. **With glossy finish both inside and outside, and large C handle.**

FR > Mug céramique préparé pour la sublimation. **Avec une finition glossy intérieur, extérieur, et une large anse en C.**

ES > Taza de cerámica preparada para sublimación. **Con acabado brillante tanto dentro como fuera, y mango grande con forma de C.**

DE > Keramikbecher für Sublimation. **Mit Glanzoberfläche an der Innen- und Außenseite und großem C-Henkel**

IT > Tazza in ceramica preparata per sublimazione. **Con finitura lucida all'interno e all'esterno e ampio manico a mezzaluna.**



3837

OFFICE ACCESSORIES

MUGS

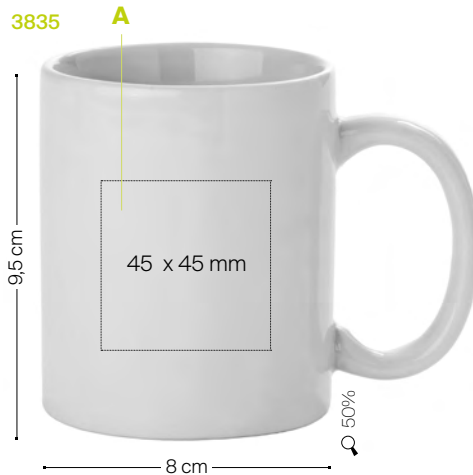

3835

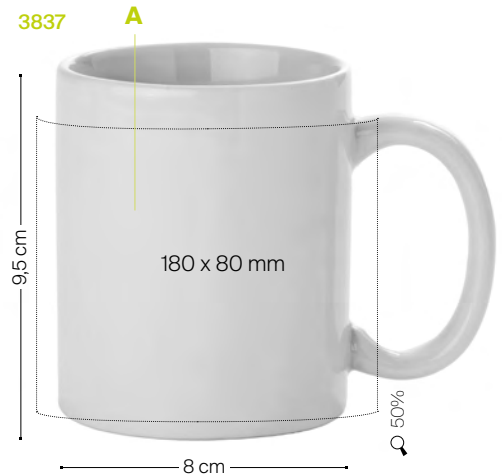

3837

3835

A> SP: max. 1 colour

3837

A> SU: 4-colour process

3835



3837



MOQ: 50 u. 3835 3837
36 36
±13 Kg ±13 Kg

Laser Mug



- EN >** Ceramic mug with matte finish, **ideal to be printed in laser engraving.**
- FR >** Mug céramique avec une finition mate, **idéal pour être imprimé en gravure laser.**
- ES >** Taza de cerámica con acabado mate, **ideal para imprimir con grabado laser.**
- DE >** Keramikbecher mit matter Oberfläche. **Ideal für Lasergravur.**
- IT >** Tazza in ceramica con finitura opaca, **ideale per incisione con laser.**



MUGS

OFFICE ACCESSORIES

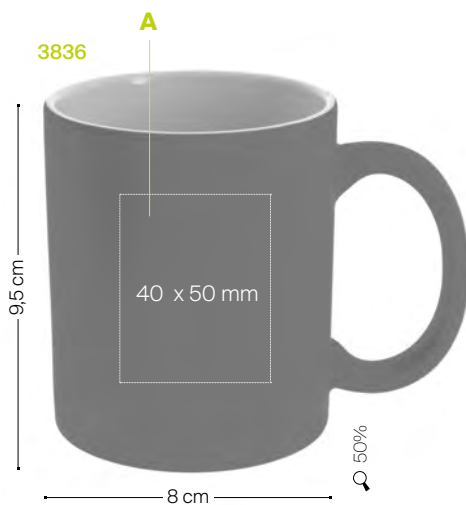

3836
 A > LE

3836

02 03 07

3836
 MOQ: 50 u. 36
 ±13 Kg

LIGHTERS

- 200 BIC® J25 Lighter
- 202 BIC® J25 Lighter *britePix*™
- 203 BIC® J25 Digital Lighter
- 204 BIC® J23 Lighter
- 205 BIC® J23 Digital Lighter
- 206 BIC® J26 Lighter
- 207 BIC® J26 Digital Lighter
- 210 BIC® J38 Lighter
- 211 BIC® J38 Digital Lighter
- 212 BIC® J39 Lighter
- 213 BIC® J39 Digital Lighter
- 215 BIC® Mega Lighter
- 215 BIC® Mega Lighter *britePix*™

LIGHTER CASES

- 218 BIC® Styl'it Luxury Case Neon
- 218 BIC® Styl'it Luxury Case Neon *britePix*™
- 219 BIC® Styl'it Luxury Case
- 219 BIC® Styl'it Luxury Case *britePix*™
- 220 BIC® Styl'it Luxury Case Soft
- 220 BIC® Styl'it Luxury Case Metallic
- 221 BIC® Aluminium Flat Case
- 221 BIC® Aluminium Flat Case *britePix*™
- 222 BIC® Clip Case *britePix*™
- 223 BIC® Styl'it Fashion Case
- 223 BIC® Styl'it Fashion Case *britePix*™
-  224 BIC® 3D Case

OTHER PRODUCTS

- 225 BIC® Pocket Ashtray
-  225 BIC® Pocket Ashtray Kraft



LIGHTERS

Top 10 reasons why...

**FR > Les 10 principales raisons pour lesquelles...
...les briquets  sont différents**

01 Forme unique

La découpe ovale unique des briquets BIC® est devenue iconique.

02 Production en interne

Des matières premières à l'emballage, la production des briquets BIC® est entièrement intégrée. Dans les usines de briquets BIC®, les méthodes de fabrication brevetées, les processus d'assemblage identiques et les contrôles automatiques cohérents garantissent un niveau de qualité élevé et constant.

03 Matières premières de qualité

BIC utilise uniquement les meilleures matières premières afin de garantir la qualité de ses produits. Le gaz présent dans les réservoirs est de l'isobutane pur, qui engendre une flamme d'une hauteur constante durant toute la durée de vie du briquet. Le réservoir est en résine à forte résistance mécanique (Delrin®).

04 Processus de fabrication high-tech

BIC a spécifiquement conçu et développé des équipements techniques de pointe, notamment des appareils photo numériques capables de mesurer très précisément des caractéristiques telles que la hauteur de la flamme, sa stabilité et son extinction.

05 Normes de sécurité

Tous les briquets de poche BIC® respectent les exigences des normes et réglementations internationales (ISO 9994, EN13869, ASTM F400, US CPSC) et vont même au-delà.

06 Tests unitaires

Avant de quitter l'usine, chaque briquet BIC® fait l'objet de plus de 50 vérifications automatiques de qualité et de sécurité. Même les briquets qui sont déjà sur le marché sont régulièrement testés.

07 Salariés dûment formés

Les salariés qualifiés et formés de BIC consacrent plus de 25 % de leur temps à contrôler la qualité.

08 Tests finaux

À la fin du processus d'assemblage, un système de contrôle automatique exécute un test complet pour s'assurer que chaque système d'allumage de briquet fonctionne parfaitement.

09 Partout dans le monde

Qu'ils soient à pierre ou électroniques, mini ou maxi, les briquets BIC® sont disponibles dans le monde entier.

10 Excellent rapport qualité/prix

Un briquet BIC® J26 produit jusqu'à 3 000 flammes, c'est-à-dire deux fois plus que d'autres briquets à pierre du même format.



01

UNIQUE SHAPE

The unique oval shape of BIC® lighters has become iconic.

02

IN-HOUSE PRODUCTION

BIC® lighter manufacturing is fully integrated from raw materials to the packaged lighter. In our lighter factories, proprietary manufacturing methods, identical assembly processes and consistent automatic controls guarantee a high and consistent level of quality.



03

BEST RAW MATERIALS

BIC Group uses only the best raw materials to ensure top quality products. The gas in the reservoir is pure isobutane, guaranteeing a flame of the same height for the entire lifespan of the lighter. The reservoir is made of high mechanical resistance resin (Delrin®).



04

HIGH-TECH MANUFACTURING PROCESS

BIC Group has specifically designed and developed state-of-the-art technical equipment, including digital cameras capable of measuring characteristics such as flame height, stability and extinguishment with extreme precision.



05

SAFETY STANDARDS

All BIC® pocket lighters meet or exceed international standards and regulation requirements (ISO 9994, EN13869, ASTM F400, US CPSC).

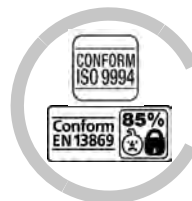

DE > Top 10 Gründe, weshalb...

... Feuerzeuge anders sind

01 Einzigartige Form

Der einzigartige ovale Form der BIC®-Feuerzeuge hat ikonischen Charakter.

02 Eigenfertigung

BIC®-Feuerzeugproduktion ist vom Rohmaterial bis zum fertig verpackten Feuerzeug vollständig integriert. In den BIC® Feuerzeugfabriken garantieren geschützte Fertigungsverfahren, identische Montageprozesse und fortlaufende automatische Kontrollen ein hohes und andauerndes Qualitätsniveau.

03 Beste Rohmaterialien

BIC® setzt nur beste Rohstoffe ein, um Top-Qualitätsprodukte zu garantieren. Das Gas im Tank ist reines Isobutan, das eine Flamme in stets gleicher Höhe für die gesamte Lebensdauer garantiert. Der Tank besteht aus Harz mit hoher mechanischer Widerstandsfähigkeit (Delrin®).

04 High-Tech Fertigungsprozess

BIC® verfügt über in Design und Entwicklung spezielles, hochmodernes technisches Equipment. Dazu gehören auch digitale Cameras, um Eigenschaften wie Flammenhöhe, -stabilität und -erlöschen extrem präzise messen zu können.

05 Sicherheitsstandards

Alle BIC®-Taschenfeuerzeuge erfüllen oder übertreffen

internationale Standards und Verordnungen (ISO 9994, EN13869, ASTM F400, US CPSC).

06 Individuelle Tests

Vor dem Verlassen der Fertigung durchläuft jedes BIC® Feuerzeug über 50 automatische Qualitäts- und Sicherheitschecks. Selbst Feuerzeuge, die bereits auf dem Markt sind, werden regelmäßig getestet.

07 Umfassend ausgebildete Mitarbeiter

Qualifizierte und geschulte BIC®-Mitarbeiter widmen über 25 % ihrer Zeit der Qualitätsüberwachung.

08 Abschlusstests

In der letzten Phase des Montageprozesses durchläuft ein Feuerzeug einen vollständigen Testlauf mittels eines automatisierten Überwachungssystems, um sicher zu stellen, dass das Zündsystem perfekt funktioniert.

09 Überall auf der ganzen Welt

Reibrad oder elektronisch, Mini- oder Maxigröße, Verbraucher auf der ganzen Welt verwenden BIC® Feuerzeuge.

10 Bestes Preis-Leistungsverhältnis

Ein BIC® J26 Feuerzeug erzeugt bis zu 3.000 Flammen. Das ist zweimal so viel wie bei anderen Reibrad-Feuerzeugen der gleichen Größe.



Lighters are different



06

INDIVIDUAL TESTING

Before leaving the factory, every BIC® lighter undergoes more than 50 automatic quality and security checks. Even lighters that are already in the marketplace are tested on a regular basis.

07

FULLY TRAINED EMPLOYEES

Qualified and trained BIC Group employees dedicate more than 25% of their time to monitoring the quality.



08

FINAL TESTS

At the final stage of the assembly process, an automatic monitoring system integrates a full test run to ensure that each lighter's lighting system is working perfectly.

09

EVERYWHERE AROUND THE WORLD

Flint or electronic, mini or maxi size, BIC® lighters can be found by consumers all around the world.



10

BEST VALUE FOR MONEY

A BIC® J26 lighter provides up to 3,000 flames. This is two times more lights than other flint lighters of the same format.

**ES > Las 10 principales razones por las que...
...los encendedores BIC® son diferentes**

01 Forma única

La forma ovalada única de los encendedores BIC® se ha convertido en un icono.

02 Producción hecha en casa

La fabricación de un encendedor BIC® está totalmente integrada, desde la materia prima hasta el envasado final. En las fábricas de encendedores BIC® los métodos de fabricación patentados, los idénticos procesos de montaje y unos consistentes controles automáticos, garantizan un consistente alto nivel de calidad.

03 La mejor materia prima

BIC utiliza la mejor materia prima para garantizar la mejor calidad de los productos. El gas del depósito es de isobutano puro, garantizando así que la llama se mantenga a la misma altura durante toda la vida útil del encendedor. El depósito está hecho de resina resistente y de alta calidad (Delrin®).

04 Proceso de fabricación de alta tecnología

BIC dispone de equipamiento técnico de vanguardia específicamente diseñado y desarrollado, incluyendo cámaras digitales capaces de medir con extrema precisión características tales como la altura de la llama, la estabilidad y la extinción.

05 Estándares de seguridad

Todos los encendedores de bolsillo BIC® cumplen o exceden las normas internacionales y los

requisitos reglamentarios (ISO 9994, EN13869, ASTM F400, US CPSC).

06 Pruebas individuales

Antes de salir de la fábrica, cada encendedor BIC® se somete a más de 50 controles automáticos de calidad y seguridad. Incluso los encendedores que ya están en el mercado son probados regularmente.

07 Empleados totalmente capacitados

Empleados BIC calificados y capacitados dedican más del 25% de su tiempo a monitorizar la calidad.

08 Pruebas finales

Al final del proceso de montaje, un sistema de monitorización automático integra una completa prueba para asegurar que el sistema de encendido de cada encendedor funciona perfectamente.

09 En cualquier lugar del mundo

De piedra o electrónicos, de tamaño mini o maxi, los encendedores BIC® pueden ser encontrados por los clientes en todo el mundo.

10 Mejor relación calidad-precio

El encendedor de piedra BIC® J26 proporciona hasta 3.000 encendidos. Esto es dos veces más que otros encendedores de piedra del mismo formato.

IT > 10 motivi principali per i quali...

gli accendini BIC® sono differenti

01 Forma unica

La forma unica ovale degli accendini BIC® è diventata iconica.

02 Produzione interna

La produzione di accendini BIC® è completamente integrata, dalle materie prime al confezionamento. Nelle fabbriche di accendini BIC, i metodi di produzione brevettati, i processi di assemblaggio identici e i controlli automatici garantiscono un livello di qualità superiore e costante.

03 Le migliori materie prime

BIC utilizza esclusivamente le migliori materie prime per garantire prodotti di alta qualità. Il gas nel serbatoio è isobutano puro, che garantisce una fiamma costante per l'intera durata dell'accendino. Il serbatoio è realizzato in resina ad alta resistenza meccanica (Delrin®).

04 Processo di produzione ad alta tecnologia

BIC ha specificamente progettato e sviluppato attrezzature tecniche all'avanguardia, comprese macchine fotografiche digitali in grado di misurare con estrema precisione caratteristiche quali altezza, stabilità ed estinzione della fiamma.

05 Standard di sicurezza

Tutti gli accendini tascabili BIC® soddisfano o eccedono gli standard internazionali e i requisiti normativi (ISO 9994, EN 13869, ASTM F400, US CPSC).

06 Collaudo individuale

Prima di lasciare la fabbrica, ogni accendino BIC® è sottoposto a più di 50 controlli automatici di qualità e sicurezza. Anche gli accendini già in commercio vengono collaudati periodicamente.

07 Dipendenti ben addestrati

I dipendenti BIC, qualificati e addestrati, dedicano più del 25% del loro tempo al monitoraggio della qualità.

08 Test finali

Nella fase finale del processo di assemblaggio, un sistema di monitoraggio automatico esegue un test completo per garantire il perfetto funzionamento del sistema di accensione di ogni accendino.

09 In tutto il mondo

A pietra o elettronici, Mini o Maxi, gli accendini BIC® sono reperibili in qualsiasi parte del mondo.

10 Il miglior rapporto qualità-prezzo

Un accendino a pietra BIC® J26 fornisce fino a 3000 accensioni. Ciò significa il doppio rispetto ad altri accendini a pietra dello stesso formato.

FR > La sécurité, notre priorité**BIC®: LE N° 1 MONDIAL EN BRIQUETS DE MARQUE**

FLAMME STABLE
Grâce au combustible pur d'isobutane

CAPUCHON DE SÉCURITÉ
Fabriqué en acier résistant avec verrouillage de sécurité

HAUTE RÉSISTANCE
Réservoir fabriqué avec une résine technique (Delrin®) à haute résistance mécanique

SÉCURITÉ ENFANTS*
Conforme à la norme EN 13869

BRIQUET LONGUE DURÉE
Grâce au plus grand volume de gaz dans le réservoir: JUSQU'À 3 000 ALLUMAGES

BRIQUETS BIC®. NOTRE QUALITÉ. VOTRE SÉCURITÉ

* Un briquet "sécurité enfants" n'est pas un briquet exempt de tout risque pour les enfants: c'est un briquet que 85% au moins des enfants de moins de 51 mois ne peuvent pas faire fonctionner, ce qui implique que la proportion des enfants en cause capables de l'actionner peut aller jusqu'à 15%. Les adultes doivent donc toujours veiller à ce que les briquets soient hors de portée des enfants, même s'il s'agit de briquets « sécurité enfants ».

ES > La seguridad, nuestra prioridad**BIC®: LA MARCA N°1 EN TODO EL MUNDO EN ENCENDEDORES DE BOLSILLO**

LLAMA ESTABLE
Gracias al combustible puro de isobutano

CAPUCHÓN DE SEGURIDAD
Hecho de acero resistente con función de bloqueo

ALTA RESISTENCIA
Depósito hecho de resina de alta resistencia mecánica (Delrin®)

PROTECCIÓN A PRUEBA DE NIÑOS*
Cumple con la normativa EN 13869

ENCENDEDOR DE LARGA DURACIÓN
Gracias al gran volumen de gas en su depósito: HASTA 3.000 ENCENDIDOS

ENCENDEDORES BIC®, NUESTRA CALIDAD, TU SEGURIDAD

* No es lo mismo un encendedor con seguridad para niños que un encendedor a prueba de niños. Por "encendedor con seguridad para niños" se entiende un encendedor que para un mínimo del 85% de los niños de hasta 51 meses de edad resulta imposible de accionar. Esto significa que hasta un 15% de los niños sí podrían hacer funcionar el encendedor. De ahí que los adultos deban siempre impedir que los niños jueguen con encendedores, por seguros que éstos sean.

DE > Die Sicherheit, unsere Priorität**BIC®: WELTWEIT DIE NR.1 UNTER DEN MARKEN-FEUERZEUGEN**

STABILE FLAMME
Dank des reinen Isobutan-Brennstoffs

SICHERHEITSKAPPE
Aus widerstandsfähigem Stahl mit Sperrfunktion

BRUCHFEST
Behälter aus äußerst stoßfestem technischem Thermoplast (Delrin®)

KINDERSICHERUNG*
Erfüllt die Vorschrift EN 13869

LANGLEBIGES FEUERZEUG
Dank des größeren Gasvolumens im Behälter: BIS ZU 3000 ZÜNDUNGEN

BIC®-FEUERZEUGE. UNSERE QUALITÄT. IHRE SICHERHEIT

* Ein kindergesichertes Feuerzeug ist nicht unbedingt kindersicher. Als "kindergesichert" bezeichnet man Feuerzeuge, die von mindestens 85% der Kinder unter 51 Monaten nicht bedient werden können. Das bedeutet, dass bis zu 15% der Kinder diese Feuerzeuge möglicherweise bedienen können. Daher müssen Sie Feuerzeuge – auch wenn sie kindergesichert sind – stets außerhalb der Reichweite von Kleinkindern aufbewahren.

IT > La sicurezza, la nostra priorità**BIC®: IL N° 1 MONDIALE PER GLI ACCENDINI TASCABILI DI MARCA**

FIAMMA STABILE
Grazie all'isobutano puro

CAPPUCCIO DI SICUREZZA
Realizzato in acciaio resistente e con funzione di blocco

OTTIMA RESISTENZA
Serbatoio realizzato in resina ad alta resistenza meccanica (Delrin®)

DISPOSITIVO DI SICUREZZA PER BAMBINI*
Conforme allo standard EN 13869

UN ACCENDINO DI LUNGA DURATA
Grazie a un maggior volume di gas nel serbatoio. FINO A 3000 ACCENSIONI

ACCENDINI BIC®, LA NOSTRA QUALITÀ, LA TUA SICUREZZA

* Un accendino dotato di dispositivo di sicurezza per i bambini non è un accendino a prova di bambino. Infatti, un accendino sicuro per i bambini è un accendino che almeno l'85% dei bambini di età inferiore a 51 mesi non è in grado di far funzionare. Ciò significa però che ben il 15% dei bambini potrebbe essere capace di azionare questo tipo di accendini. Per tale motivo, gli adulti dovrebbero sempre fare in modo che i bambini non possano impadronirsi di accendini, nemmeno qualora siano dotati di un dispositivo di sicurezza per i bambini.

Safety, our priority

STABLE FLAME

Thanks to pure isobutane



SAFETY HOOD

Made of strong steel material with locking feature



HIGH RESISTANCE

Reservoir made of high mechanical resistance resin (Delrin®)



BIC J26 Lighter

CHILD-RESISTANT SAFETY GUARD*

Compliant with EN 13869 Standard

*A Child-resistant lighter is not a child proof lighter. A Child-resistant lighter is a lighter that at least 85% of children under 51 months of age cannot operate. This means that up to 15% of children may still be able to operate such a lighter. Therefore, adults should always ensure that young children cannot get hold of lighters, even if they are Child-resistant.



A LONG LASTING LIGHTER

Thanks to a greater volume of gas in the reservoir **UP TO 3000 LIGHTS**



BIC® Lighters
OUR QUALITY, YOUR SAFETY

BIC J23 Digital Lighter

BIC J26 Digital Lighter

BIC J38 Lighter

BIC J25 Lighter



Up to 1400 🔥



Up to 1800 🔥



Up to 3000 🔥



Up to 1800 🔥

BIC J39 Lighter



Up to 1050 🔥



70%

Up to 750 🔥

LIGHTERS

BIC® LIGHTERS

Our digital finishes &...

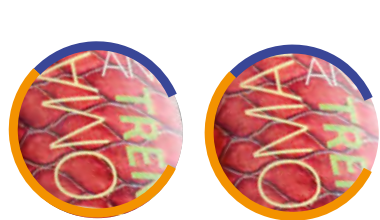

**DIGITAL BRILLIANT
DIGITAL MATT**
Brilliant or matt?
Choose the finish
you like!



METALLIC
Create great
effects! **Metallic**
effects in texts,
images and
backgrounds.



**HOLOGRAPHIC GOLD
HOLOGRAPHIC SILVER**
Stand out from the crowd!
Play with nice **light colour**
reflections using the
holographic finish.



PUFFY PRINTING
Be original!
Highlight your brand
with our "Puffy" ink
to give a relief effect
to your logo.



FR > Finitions numériques et textures des briquets

- **Digital Brilliant / Digital matt**
Brillante ou mate? Choisissez la finition qui vous plaît!
- **Metallic**
Créez de superbes effets!
Effets métalliques sur les textes, les images et le fond.
- **Holographic gold / Holographic silver**
Démarez-vous de la concurrence! Jouez avec de **jolis reflets légers de couleurs** en utilisant la finition holographique.
- **Puffy printing**
Faites preuve d'originalité!
Faites ressortir votre marque grâce à notre encre « **puffy** » et donnez ainsi du relief à votre logo.
- **UV printing**
Faites ressortir votre **marque avec une finition très brillante**! Combinez les finitions mates et brillantes pour souligner les contrastes et faire ressortir le motif sur **fond mat**.
- **Sandy**
Créez un effet « **papier de verre** » grâce à une surface granuleuse.
- **Puffy Glitter**
Admirez et touchez la **texture colorée à paillettes**!
- **Glow in the dark**
Faites briller votre marque, **même dans le noir**!

ES > Nuestros acabados digitales y texturas en los encendedores

- **Digital Brilliant / Digital matt**
¿Brillante o mate? ¡Escoge el acabado que más te guste!
- **Metallic**
¡Crea magníficos efectos!
Efectos metálicos en los textos, imágenes y fondos.
- **Holographic gold / Holographic silver**
¡Destaca entre la multitud!
Juega con **atractivos reflejos de luz** con el acabado holográfico.
- **Puffy printing**
¡Sé original! Destaca tu marca con nuestra **tinta "puffy"** para dar efecto relieve a tu logo.
- **UV printing**
¡Destaca tu marca con el **acabado de relieve brillante**! Combina mate y brillante para resaltar contrastes y destacar prominentemente en **fondo mate**.
- **Sandy**
Crea un **efecto arena** con una textura granulada.
- **Puffy Glitter**
Mira y siente la **textura brillante** coloreada!
- **Glow in the dark**
¡Haz que tu logo brille incluso en la oscuridad!

textures in Lighters



UV PRINTING

Highlight your brand with a high gloss finish!

Combine a matt & gloss finish to highlight contrasts and stand out prominently on a **matt background**.



SANDY

Create a sandpaper effect with a granulated texture.

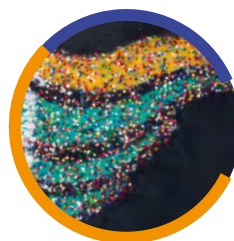

PUFFY GLITTER

Feel & see the coloured glitter texture!



EFFECT IN DAYLIGHT



EFFECT IN THE DARK

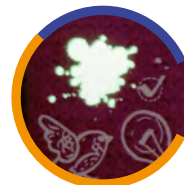

GLOW IN THE DARK

Make your brand glow even in the dark!



LIGHTERS

BIC® LIGHTERS

DE > Unsere digitalen Oberflächen & Texturen bei -Feuerzeugen

- **Digital Brilliant / Digital Matt**
Glänzend oder matt? Wählen Sie die Oberfläche, die Ihnen gefällt!
- **Metallic**
Kreieren Sie großartige Effekte! **Metallic**effekte bei Texten, Bildern und Hintergründen
- **Holographic Gold / Holographic Silver**
Heben Sie sich von der Masse ab! Spielen Sie mit den attraktiven Lichtreflexen der holographischen Oberfläche.
- **Puffy Printing**
Seien Sie originell! Heben Sie Ihre Marke hervor mit unserer "Puffy"-Tinte und verleihen Sie Ihrem Logo einen Reliefeffekt.
- **UV Printing**
Heben Sie Ihre Marke mit einer Hochglanzoberfläche heraus! Kombinieren Sie matte & glänzende Oberflächen, um Kontraste zu betonen und prominent auf mattem Untergrund hervorzutreten
- **Sandy**
Kreieren Sie einen Sandpapier-Effekt mit körniger Struktur.
- **Puffy Glitter**
Fühlen und sehen Sie die farbige Glitzer-Struktur!
- **Glow in the dark**
Lassen Sie Ihre Marke selbst in der Dunkelheit aufleuchten!

IT > Le nostre finiture digitali e le texture degli accendini

- **Digital Brilliant / Digital matt**
Brillante o opaco? Scegli la finitura che preferisci!
- **Metallic**
Crea effetti incredibili! **Effetti metallici** su testi, immagini e sfondi.
- **Holographic gold / Holographic silver**
Fatti notare! Gioca con gli attraenti riflessi di luce della finitura oleografica.
- **Puffy printing**
Sii originale! Metti in evidenza il tuo marchio con il nostro inchiostro "puffy" per dare un effetto rilievo al tuo logo.
- **UV printing**
Metti in evidenza il tuo marchio con una finitura ultra lucida! Combina una finitura opaca con una lucida per creare contrasti e dare risalto su uno sfondo opaco.
- **Sandy**
Crea un effetto carta vetrata con una texture granulata.
- **Puffy Glitter**
La texture in glitter colorati è tutta da vedere e sentire!
- **Glow in the dark**
Fai brillare il tuo marchio al buio!

BIC® LIGHTERS

LIGHTERS





J25 Lighter

Our best-seller. Pocket-sized flint lighter, in a wide range of colour combinations.



J25 Lighter

EN > Our best-seller, pocket-sized flint lighter, in a wide range of colour combinations.

FR > Notre best-seller, briquet à pierre format de poche, dans un large éventail de combinaisons de couleurs.

ES > Nuestro encendedor de piedra de bolsillo más vendido, en una amplia gama de colores.



01

2360



02



03



59



8G



57



24



25



25



57



57



57

BIC® LIGHTERS

LIGHTERS

By the expert in...

Lighters



Up to 1400

DE > Unser meistgekauftes Reibrad-Feuerzeug für die Hosentasche, in breiter Farbpalette erhältlich.

IT > Il nostro best-seller, misura tascabile, fiamma stabile, in un'ampia gamma di combinazioni colori.



02



02

2364



83

2377



84



85



90

LIGHTERS

BIC® LIGHTERS

2360
Standard

2364
All Black

2377
Pastel

A/ C > SP: max. 4 colours



MOQ: 300 u.



See details p. 195



± 76 Kg

Standard Packaging: in tray of 50 u. /
barquette 50 u. / en bandeja de 50 u. /
50er Aufsteller / In vassoi da 50 pezzi

**2360/
2364**



2377





J25 Lighter *britePix™*

By the expert in...

Lighters



Up to 1400 🔥

EN > Choose our *britePix™* full-colour print and give relief to your message with *britePix™* Texture!

FR > Choisissez notre impression *britePix™* full-colour et donnez du relief à votre message avec *britePix™* Texture.

ES > ¡Elige nuestra técnica de impresión *britePix™* a todo color y da relieve a tu mensaje con *britePix™* Texture!

DE > Entscheiden Sie sich für *britePix™*-Vollfarbdruck und verleihen Sie Ihrer Botschaft mit *britePix™* Texture einen Relief-Effekt!

IT > Scegli la nostra stampa a colori *britePix™* e dai rilievo al tuo messaggio con *britePix™* Texture!



2362

2366

2379

BIC® LIGHTERS

LIGHTERS

britePix™ / *britePix™* Texture



2362
Standard
britePix™

2366
All Black
britePix™

2379
Pastel
britePix™

A/C > BP: full-colour
A/C > BP Texture: full-colour

2362



2366



2379



Standard Packaging: in tray of 50 u. /
barquette 50 u. / en bandeja de 50 u. /
50er Aufsteller / In vassoi da 50 pezzi

MOQ: 300 u.



See details p. 195



J25 Digital Lighter

By the pioneer in...
Digital Printing

Up to 1400 🔥

EN > Choose any finish to highlight your brand and obtain impressive results: Brilliant, Matt, Holographic, Puffy Ink, UV printing, Metallic, Sandy, Puffy Glitter or Glow in the dark.

FR > Choisissez la finition que vous voulez pour **que votre marque se distingue, et pour obtenir des résultats impressionnants** : brillante, mate, holographique, encre Puffy, impression UVI, Métallique, effet grain de sable, encre Puffy ou phosphorescent.

ES > Escoge cualquier acabado para **resaltar tu marca y obtener resultados impresionantes**: brillante, mate, holográfico, impresión Puffy, UVI, metálico, efecto arena, textura brillante coloreada o efecto en la oscuridad.

DE > Wählen Sie eine Oberfläche aus, um **Ihre Marke ins richtige Licht zu setzen und beeindruckende Ergebnisse zu erzielen**: Brillant, Matt, Holographie, Puffy Ink, UV, Metallisch, Sandy, Puffy Glitter oder Glow in the dark.

IT > Scegli tra tutte le finiture per **evidenziare il tuo marchio e ottenere risultati impressionanti**: brillante, opaco, olografico, inchiostro puffy, stampa UV, metallico, Sandy, Puffy Glitter o effetto al buio.



2368
Digital

A/B/C/D > DG: area for images

LIGHTERS

BIC® LIGHTERS



See details p.195

- MOQ Digital finishes:**
- BR MATT Brilliant or Matt 600 u.
 - H Holographic..... 600 u.
 - PUFFY Puffy..... 5.100 u.
 - JV UV 5.100 u.
 - M Metallic..... 50.000 u.

- SA Sandy 5.100 u.
- PUFFY Puffy Glitter 5.100 u.
- GLOW Glow in the dark 5.100 u.

Standard Packaging: in tray of 50 u. /
barquette 50 u. / en bandeja de 50 u. /
50er Aufsteller / In vassoio da 50 pezzi

600
± 76 Kg





J23 Lighter

By the expert in...

Lighters



Up to 1800

EN > Thin and elegant. **Comfortable** to use. **Stable flame** due to pure isobutane fuel. Made of a **technical resin (Delrin®)** with high mechanical resistance.

FR > Fin et élégant. **Confortable** à l'utilisation. **Flamme stable** grâce à l'isobutane pur. Fabriqué avec de la **resine (Delrin®)** à haute résistance mécanique.

ES > Fino y elegante. **Cómodo** de usar. Llama estable gracias al combustible puro de isobutano. Hecho de una **resina técnica (Delrin®)** con resistencia mecánica alta.

DE > Schlank und elegant. **Einfach** in der Handhabung. **Gleichmäßige Flamme** dank reinen Isobutangases. Hergestellt aus **hochentwickeltem Harz (Delrin®)** mit überaus hoher mechanischer Stabilität.

IT > Sottile ed elegante. **Comodo** da usare. **Fiamma stabile** grazie al carburante in puro isobutano. Realizzato con una **resina tecnica (Delrin®)** con alta resistenza meccanica.



100%

BIC® LIGHTERS

LIGHTERS



100%

2340
Standard

A/C > SP: max. 4 colours



MOQ: 300 u.



See details p. 195

600
± 9.5 Kg



Standard Packaging: in tray of 50 u. /
barquette 50 u. / en bandeja de 50 u. /
50er Aufsteller / In vassoio da 50 pezzi



J23 Digital Lighter

By the pioneer in...
Digital Printing

Up to 1800

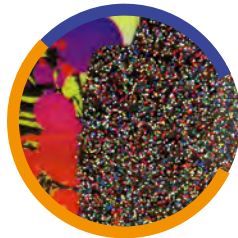

EN > Choose any finish to highlight your brand and obtain impressive results: Brilliant, Matt, Holographic, Puffy, UV printing, Metallic, Sandy, Puffy Glitter or Glow in the dark.

FR > Choisissez la finition que vous voulez pour **que votre marque se distingue, et pour obtenir des résultats impressionnants**: brillante, mate, holographique, encre Puffy, impression UVI, Métallique, effet grain de sable, encre Puffy ou phosphorescent.

ES > Escoge cualquier acabado para **resaltar tu marca y obtener resultados impresionantes**: brillante, mate, holográfico, impresión Puffy, UVI, metálico, efecto arena, textura brillante coloreada o efecto en la oscuridad.

DE > Wählen Sie eine Oberfläche aus, um **Ihre Marke ins richtige Licht zu setzen und beeindruckende Ergebnisse zu erzielen**: Brillant, Matt, Holographie, Puffy, UV, Metallic, Sandy, Puffy Glitter oder Glow in the dark.

DE > Scegli tra tutte le finiture per **evidenziare il tuo marchio e ottenere risultati impressionanti**: brillante, opaco, olografico, inchiostro puffy, stampa UV, metallico, Sandy, Puffy Glitter o effetto al buio.



100%



LIGHTERS

BIC® LIGHTERS

2347
Digital

A/B/C/D > DG: area for images



See details p. 195

- MOQ Digital finishes:**
- BR** **MATT** Brilliant or Matt 600 u.
 - H** **H** Holographic 600 u.
 - P** **P** Puffy 5.100 u.
 - UV** **UV** UV 5.100 u.
 - M** **M** Metallic 50.000 u.

- SA** **S** Sandy 5.100 u.
- P** **P** Puffy Glitter 5.100 u.
- G** **G** Glow in the dark 5.100 u.

Standard Packaging: in tray of 50 u. /
barquette 50 u. / en bandeja de 50 u. /
50er Aufsteller / In vassoi da 50 pezzi

600
+9,5 Kg





J26 Lighter

By the expert in...

Lighters



Up to 3000 🔥

EN > Extra long-lasting: **up to 3.000 lights!** Gives **up to 2 times more lights than other flint lighters** of the same format (Internal testing - EU Market 2008-2010). Comfortable to use.

FR > Longue durée : **jusqu'à 3 000 allumages.** Donne **2 fois plus d'allumages que les autres briquets à molette** du même format (testé en interne - marché EU 2008-2010). Confortable à l'utilisation.

ES > Larga duración: **hasta 3.000 encendidos!** Proporciona hasta **el doble de encendidos que otros encendedores** del mismo formato (pruebas internas - mercado UE 2008-2010). Cómodo de usar.

DE > Extra ausdauernd: **Bis zu 3.000 Zündungen!** Bis zu **2 mal mehr Zündungen als andere** Reibrad-Feuerzeuge. (Interne Tests im europäischen Markt von 2008-2010). Komfortable Handhabung.

IT > Durata extra lunga: **fino a 3.000 accensioni!** Produce fino **al doppio delle accensioni rispetto ad altri accendini** dello stesso formato (Test interni - Mercato UE 2008-2010). Comodo da usare.



59

01

02

03



BIC® LIGHTERS

LIGHTERS



8,2 cm

20 x 50 mm
SIDE A

2,5 cm

20 x 50 mm
SIDE C

2,5 cm



25

57

8G

10

2320
Standard

A/C > SP: max. 4 colours



MOQ: 300 u.



See details p. 195

Standard Packaging: in tray of 50 u. /
barquette 50 u. / en bandeja de 50 u. /
50er Aufsteller / In vassoi da 50 pezzi



± 15,1 Kg





J26 Digital Lighter

By the pioneer in...
Digital Printing

Up to 3000 🔥

EN > Choose any finish to highlight your brand and obtain impressive results: Brilliant, Matt, Holographic, Puffy, UV printing, Metallic, Sandy, Puffy Glitter or Glow in the dark.

FR > Choisissez la finition que vous voulez pour que votre marque se distingue, et pour obtenir des résultats impressionnants : brillante, mate, holographique, encre Puffy, impression UVI, Métallique, effet grain de sable, encre Puffy ou phosphorescent.

ES > Escoge cualquier acabado para resaltar tu marca y obtener resultados impresionantes: brillante, mate, holográfico, impresión Puffy, UVI, metálico, efecto arena, textura brillante coloreada o efecto en la oscuridad.

DE > Wählen Sie eine Oberfläche aus, um Ihre Marke ins richtige Licht zu setzen und beeindruckende Ergebnisse zu erzielen: Brillant, Matt, Holographie, Puffy, UV, Metallic, Sandy, Puffy Glitter oder Glow in the dark.

IT > Scegli tra tutte le finiture per evidenziare il tuo marchio e ottenere risultati impressionanti: brillante, opaco, olografico, inchiostro puffy, stampa UV, metallico, Sandy, Puffy Glitter o effetto al buio.



100%



LIGHTERS

BIC® LIGHTERS

2328
Digital

A/B/C/D> DG: area for images



See details p. 195

- MOQ Digital finishes:**
- BR MATT Brilliant or Matt600 u.
 - H Holographic.....600 u.
 - PUFFY Puffy.....5.100 u.
 - UV UV5.100 u.
 - M Metallic..... 50.000 u.

- SA Sandy.....5.100 u.
- PUFFY Puffy Glitter5.100 u.
- GLOW Glow in the dark 5.100 u.

Standard Packaging: in tray of 50 u. / barquette 50 u. / en bandeja de 50 u. / 50er Aufsteller / In vassoi da 50 pezzi



BIC® LIGHTERS

LIGHTERS





J38 Lighter

Our bestselling electronic lighter. Elegant & comfortable lighting thanks to one-step ignition mechanism. Also available with golden colour hood to give your message a touch of class.



J38 Lighter

By the expert in...

Lighters



Up to 1800

EN > Our bestselling electronic lighter. **Elegant & comfortable lighting thanks to one-step ignition mechanism.** Also available with a golden colour hood to give your message a touch of class.

FR > Notre briquet électronique champion des ventes ! **Allumage élégant et pratique, grâce à son système d'allumage piezo.** Disponible également avec capot couleur or, pour donner à votre message une touche élégante.

ES > El encendedor electrónico más vendido. Encendido **cómodo y elegante, gracias al mecanismo de ignición de un sólo paso.** También disponible el capuchón en color dorado para dar a tu mensaje un toque de clase.

DE > Unser meistgekauftes Elektronik-Feuerzeug. **Elegantes und komfortables Zünden dank des einstufigen Zündungsmechanismus.** Auch mit goldfarbiger Kappe erhältlich. Verleiht Ihrer Botschaft einen Touch von Extraklasse.

IT > Il nostro accendino elettronico più venduto. **Elegante e comodo grazie al meccanismo di accensione a una sola fase.** Disponibile anche con frangifiamma colore oro per dare al tuo messaggio un tocco di classe.

2452
Chrome Hood

2451
Gold Hood

A/C > SP: max. 4 colours



2452



2451

100%



100%

2452



2451



MOQ: 300 u.



See details p. 195

600
± 13,2 Kg

MADE IN SPAIN

Standard Packaging: in tray of 50 u. / barquette 50 u. / en bandeja de 50 u. / 50er Aufsteller / In vassoio da 50 pezzi





J38 Digital Lighter

By the pioneer in...
Digital Printing

Up to 1800

EN > Choose any finish to highlight your brand and obtain impressive results: Brilliant, Matt, Holographic, Puffy, UV printing, Metallic, Sandy, Puffy Glitter or Glow in the dark.

FR > Choisissez la finition que vous voulez pour que votre marque se distingue, et pour obtenir des résultats impressionnants : brillante, mate, holographique, encre Puffy, impression UVI, Métallique, effet grain de sable, encre Puffy ou phosphorescent.

ES > Escoge cualquier acabado para resaltar tu marca y obtener resultados impresionantes: brillante, mate, holográfico, impresión Puffy, UVI, metálico, efecto arena, textura brillante coloreada o efecto en la oscuridad.

DE > Wählen Sie eine Oberfläche aus, um Ihre Marke ins richtige Licht zu setzen und beeindruckende Ergebnisse zu erzielen: Brillant, Matt, Holographie, Puffy, UV, Metallic, Sandy, Puffy Glitter oder Glow in the dark.

IT > Scegli tra tutte le finiture per evidenziare il tuo marchio e ottenere risultati impressionanti: brillante, opaco, olografico, inchiostro puffy, stampa UV, metallico, Sandy, Puffy Glitter o effetto al buio.



2458
Digital

A/B/C/D > DG: area for images



See details p. 195

- MOQ Digital finishes:**
- BR** Brilliant or Matt 600 u.
 - H** Holographic 600 u.
 - PUFFY** Puffy 5.100 u.
 - UV** UV 5.100 u.
 - M** Metallic 50.000 u.

- SA** Sandy 5.100 u.
- PUFFY GLITTER** Puffy Glitter 5.100 u.
- GLOW** Glow in the dark 5.100 u.

Standard Packaging: in tray of 50 u. /
barquette 50 u. / en bandeja de 50 u. /
50er Aufsteller / In vassoio da 50 pezzi

600
+ 13,2Kg



LIGHTERS

BIC® LIGHTERS



J39 Lighter

By the expert in...

Lighters



Up to 1050

- EN >** Convenient mini size. **Comfortable lighting**, thanks to one-step ignition mechanism.
- FR >** Taille mini et pratique. **Allumage pratique** grâce à son système piezo.
- ES >** Práctico tamaño pequeño. Encendido **cómodo y elegante**, gracias al mecanismo de ignición de un solo paso.
- DE >** Praktisches Miniformat. **Komfortables Zünden** dank des einstufigen Zündungsmechanismus.
- IT >** Pratico formato mini. **Comodo utilizzo** grazie al meccanismo di accensione a una sola fase.



100%

BIC® LIGHTERS

LIGHTERS



100%

2479
Chrome Hood

A/C > SP: max. 4 colours



MOQ: 300 u.



600
±11 Kg



Standard Packaging: in tray of 50 u. /
barquette 50 u. / en bandeja de 50 u. /
50er Aufsteller / In vassoio da 50 pezzi

See details p. 195



By the pioneer in...
Digital Printing

Up to 1050

J39 Digital Lighter

EN > Choose any finish to highlight your brand and obtain impressive results: Brilliant, Matt, Holographic, Puffy, UV printing, Metallic, Sandy, Puffy Glitter or Glow in the dark.

FR > Choisissez la finition que vous voulez pour que votre marque se distingue, et pour obtenir des résultats impressionnants : brillante, mate, holographique, encre Puffy, impression UVI, Métallique, effet grain de sable, encre Puffy ou phosphorescent.

ES > Escoge cualquier acabado para resaltar tu marca y obtener resultados impresionantes: brillante, mate, holográfico, impresión Puffy, UVI, metálico, efecto arena, textura brillante coloreada o efecto en la oscuridad.

DE > Wählen Sie eine Oberfläche aus, um Ihre Marke ins richtige Licht zu setzen und beeindruckende Ergebnisse zu erzielen: Brillant, Matt, Holographie, Puffy, UV, Metallisch, Sandy, Puffy Glitter oder Glow in the dark.

IT > Scegli tra tutte le finiture per evidenziare il tuo marchio e ottenere risultati impressionanti: brillante, opaco, olografico, inchiostro puffy, stampa UV, metallico, Sandy, Puffy Glitter o effetto al buio.



100%

LIGHTERS

BIC® LIGHTERS



100%

2481
Digital

A/B/C/D > DG: area for images



See details p. 195

- MOQ Digital finishes:**
- BR** MATT Brilliant or Matt600 u.
 - H** Holographic600 u.
 - PUFFY** Puffy5.100 u.
 - UV** UV5.100 u.
 - M** Metallic 50.000 u.

- SA** Sandy5.100 u.
- PUFFY GLITTER** Puffy Glitter5.100 u.
- GLOW** Glow in the dark 5.100 u.

Standard Packaging: in tray of 50 u. / barquette 50 u. / en bandeja de 50 u. / 50er Aufsteller / In vassoi da 50 pezzi

600
+11,1 Kg



Mega Lighter



BIC® LIGHTERS

LIGHTERS



Mega Lighter & britePix™

Up to 750

EN > Curved body shape for **comfortable handling**. Compact and trendy. A retractable **hook for easy storage**. **Visible gas supply**: easy to check the gas level. Try **britePix™ Texture** to give a relief effect to your communication!

FR > Forme plus incurvée du corps pour une **manipulation agréable**. Compact et moderne. **Crochet rétractable pour un rangement facile**. **Alimentation visible du gaz** : facile pour contrôler le niveau de gaz. **Essayez la texture britePix™ pour donner du relief à votre communication !**

ES > Forma del cuerpo curvada para un **cómodo manejo**. Compacto y moderno. **Gancho plegable para colgarlo con facilidad**. **Suministro de gas visible**: es fácil comprobar el nivel de gas. **¡Elige britePix™ Texture para dar un efecto relieve a tu mensaje!**

DE > Geschwungener Schaft für **angenehme Handhabung**. Kompakt und trendig. **Versenkbarer Aufhänger für einfache Aufbewahrung**. **Gastank-Fenster**: einfach ablesbarer, aktueller Füllstand. **Testen Sie britePix™ Texture und verleihen Sie Ihrer Botschaft einen Reliefeffekt!**

IT > Forma del corpo ricurva per una **comoda maneggevolezza**. Compatto e trendy. **Gancio retraibile per riporlo facilmente**. **Livello del gas visibile**, per un più facile controllo. **Prova la texture britePix™ per dare un effetto rilievo alla tua comunicazione!**



LIGHTERS

BIC® LIGHTERS

2500



2501 britePix™



2500

2501 britePix™

A/B > PD: max. 2 colours

B > BP: full-colour

B > BP Texture: full-colour



britePix
Texture

Conform
ISO22702

MOQ: 100 u.

100
± 703 Kg



Standard packaging: 100 pcs in an export carton in grid / Embalaje estándar: 100 ud por caja en rejilla / 100 Stück im Umkarton mit Rastertrennung / Confezione standard: cartone espositore da 100 pezzi con griglia.

Lighter Cases



BIC® LIGHTERS

LIGHTER CASES

Why Lighter Cases?

Maximize your brand visibility thanks to BIC® Lighter Cases



FR > Pourquoi opter pour un étui à briquet ?

Maximisez la visibilité de votre marque grâce aux étuis à briquet BIC®.

- Accessoire pour votre briquet BIC®
- Orifices de ventilation
- Sécurité maximale pour les consommateurs
- Accessoire idéal
- Visibilité de votre marque avec les briquets de poche BIC®.
- Toutes les coques BIC® sont livrées avec un briquet BIC® J25 blanc.

ES > ¿Por qué las fundas ?

Maximiza la visibilidad de tu marca gracias a las fundas para encendedores BIC®.

- Complemento para nuestro encendedor BIC®
- Agujeros de ventilación
- Máxima seguridad para los consumidores
- Magnífico accesorio
- Visibilidad de tu marca con el encendedor de bolsillo BIC®.
- Todas las fundas BIC® se entregan con un encendedor BIC® J25 blanco.

DE > Weshalb Feuerzeughüllen?

Maximieren Sie die Sichtbarkeit Ihrer Marke mit den BIC® Feuerzeughüllen.

- Ergänzung für Ihr BIC® Feuerzeug.
- Ventilationsöffnungen
- Maximale Sicherheit für Verbraucher
- Großartiges Accessoire
- Markensichtbarkeit mit BIC®-Taschenfeuerzeugen.
- Alle BIC®-Feuerzeughüllen werden mit weißem BIC® J25-Feuerzeug ausgeliefert.

IT > Perché utilizzare i copri accendini ?

Ottimizza la visibilità del tuo marchio grazie ai copri accendini BIC®.

- Complemento per l'accendino BIC®
- Fori per la ventilazione
- Massima sicurezza per i consumatori
- Accessorio ideale
- Visibilità del tuo marchio con l'accendino tascabile BIC®.
- Tutti i copri accendini BIC® sono consegnati con un accendino BIC® J25



Styl'it Luxury Case Neon & britePix™

EN > Dress up your BIC® J25 lighter in any of the 4 trendy colours!

FR > Habillez votre briquet BIC® J25 avec les couleurs tendances!

ES > ¡Viste tu encendedor BIC® J25 con cualquiera de los 4 colores de moda!

DE > Putzen Sie Ihr BIC® J25-Feuerzeug in einer dieser 4 trendigen Farben heraus!

IT > Rivesti il tuo accendino BIC® J25 con uno dei 4 colori moda!



2386

2396

2386 LE

2396 britePix™



2386
A/C > LE

2396 britePix™
A/C > BP: full-colour

2386 / 2396



2F

59

1G

5C



MOQ: 100 u.



300
± 61 Kg



Standard Packaging: box for 10 units

See details p. 195



Styl'it Luxury Case & britePix™

- EN >** Premium lighter case available in attractive shiny colours, also available with the our britePix™ full-colour print.
- FR >** Les coques premium sont disponibles dans des finitions attractives et également avec l'impression britePix™.
- ES >** Funda de encendedor premium con atractivos colores brillantes y también disponible con impresión britePix™ a todo color.
- DE >** Premium-Feuerzeughülle in attraktiven, glänzenden Farben. Auch mit britePix™-Vollfarbdruck erhältlich.
- IT >** Copri accendino Premium disponibile in attrattenti colori lucidi, disponibile anche con stampa in full-colour britePix™.



2381



2159



2381

2159 britePix™



2381
A/C > LE

2159 britePix™
A/C > BP: full-colour

2381 / 2159



01

47



MOQ: 100 u.



See details p. 195



Standard Packaging: box for 10 units

LIGHTER CASES

BIC® LIGHTERS



Styl'it Luxury Case Soft & Metallic

- EN >** Our best-selling lighter case for our BIC® J25 lighter, available in attractive metallic and soft finishes. **Try our HD laser engraving for a touch of elegance!**
- FR >** Notre best-seller en coque pour briquet BIC® J25, disponible dans des finitions métalliques attractives et soft. **Essayez notre gravure laser HD pour une touche d'élégance!**
- ES >** Nuestra funda de encendedor más vendida para BIC® J25, disponible en atractivo metal y acabados soft. **¡Elige nuestro grabado láser HD para dar un toque de elegancia!**
- DE >** Unsere meistgekauft Feuerzeughülle für das BIC® J25-Feuerzeug. In attraktiven Metallicfarben und mit Softoberflächen. **Wählen Sie unsere HD-Lasergravur für einen Hauch von Eleganz.**
- IT >** Il nostro copri accendino piú venduto per accendino BIC® J25, disponibile con attraenti finiture metalliche e soft. **Prova la nostra incisione laser HD per un tocco di eleganza!**



2153

2161

100%

BIC® LIGHTERS

LIGHTER CASES

2153 / 2161 Metallic LE



100%

2153
BIC® Styl'it Luxury Soft
*2161
BIC® Styl'it Luxury Metallic

A/C > LE

2153



01

02

25

47

*2161



02

34

47

*While stock lasts

MOQ: 100 u.



See details p. 195

300
± 6,1 Kg



Standard Packaging: box for 10 units



Aluminium Flat Case

& **britePix™**

EN > Trendy aluminium case with a light weight & with a flat surface design for BIC® J25 lighter. **Great personalization area for maximum brand communication: 3 sides can be personalized.**

FR > Étui en aluminium à la mode, léger et au design comprenant une surface plate, pour le briquet BIC® J25. **Large zone à personnaliser pour une communication optimale de votre marque : 3 côtés personnalisables.**

ES > Funda de aluminio a la moda de peso ligero y diseño con superficie plana, para el encendedor BIC® J25. **Gran área de personalización para una máxima comunicación de marca: se pueden personalizar 3 caras.**

DE > Trendige, leichtgewichtige Aluminiumhülle mit flachem Oberflächen-Design für das BIC® J25-Feuerzeug. **Große Personalisierungsfläche für Ihre maximale Markenbotschaft: 3 Seiten können personalisiert werden.**

IT > Porta accendino alla moda, leggero e con un design piatto per l'accendino BIC® J25. **Grande area personalizzabile per la massima comunicazione del marchio: si possono personalizzare 3 lati.**



100%

LIGHTER CASES

BIC® LIGHTERS

2156

2157 **britePix™**



2156

A/C> LE
B> LE

2157 **britePix™**

A/C>
BP: full-colour
B>
BP: full-colour



01

02

03

07

47

MOQ: 100 u.



See details p. 195



Standard Packaging: box for 50 units



Clip Case

britePix™

- EN >** Wide printing surface in full-colour, also available with britePix™ Texture to give a relief effect to your communication. Ideal to attach to the top of your pack of cigarettes. Full-colour on the go!
- FR >** Large surface d'impression avec britePix™ Texture pour donner du relief à votre communication. Idéal pour attacher sur le dessus de votre paquet de cigarettes. Mettez de la couleur!
- ES >** Amplia superficie de impresión a todo color, también disponible con britePix™ Texture que dará un efecto de relieve a tu comunicación. Ideal para fijar en la parte superior de tu paquete de cigarrillos. ¡Llévalo a todo color!
- DE >** Große Druckfläche mit britePix™ Texture - verleiht Ihrer Botschaft einen Relief-Effekt. Lässt sich ideal auf Ihrer Zigarettenschachtel platzieren. Volles Farbspektrum für unterwegs!
- IT >** Ampia superficie di stampa con britePix™ Texture per dare un effetto di rilievo alla tua comunicazione. Ideale da fissare nella parte superiore del tuo pacchetto di sigarette. Passa al colore!



100%

BIC® LIGHTERS

LIGHTER CASES

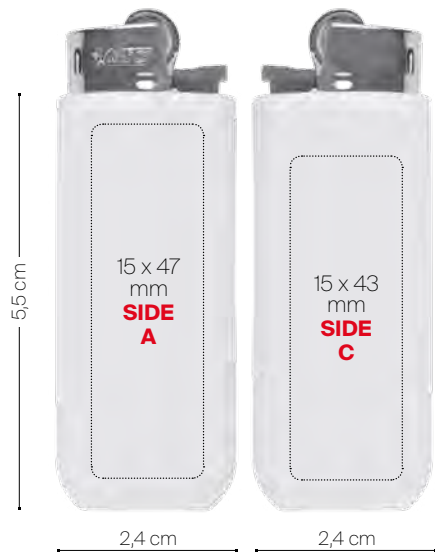

100%



2398
britePix™

A/C> BP: full-colour
A/C> BP Texture: full-colour



MOQ: 100 u.



See details p. 195

300
± 75 Kg



Standard Packaging: box for 50 units



Styl'it Fashion Case

& britePix™

- EN >** Trendy, hard plastic case: also available with the **britePix™ Texture** that gives a relief effect to your communication!
- FR >** Étui moderne en plastique rigide. Aujourd'hui également disponible **britePix™ Texture**, qui apporte du relief à votre communication !
- ES >** Moderna funda de plástico rígido. ¡También disponible **con britePix™ Texture** que dará un efecto de relieve a tu comunicación!.
- DE >** Trendige Hülle aus hartem Kunststoff. Auch mit **britePix™ Texture**, um Ihre Botschaft mit einem Relief zu betonen.
- IT >** Moderno porta accendino in plastica rigida. Disponibile anche **con britePix™ Texture** per dare rilievo alla tua comunicazione!



2390

2399

100%



71 cm

20 x 35 mm

SIDE A

20 x 35 mm

SIDE C

3,1 cm

3,1 cm

100%

***2390**
Styl'it Fashion

A/C > PD: max. 1 colour

***2399**
britePix™

A/C > BP: full-colour



66

67

*While stock lasts



MOQ: 100 u.



See details p. 195

300
± 8,05 Kg



Standard Packaging: box for 50 units

LIGHTERCASES

BIC® LIGHTERS



3D case



- EN >** 100% customised case! **Your logo converted into a 3D shape.** Soft-touch. Available for BIC® J25 Lighter.
- FR >** Étui 100% personnalisable! **Votre logo convertit en 3D.** Touché soft. Disponible pour briquet BIC® J25.
- ES >** ¡Funda 100% personalizada! **Tu logo convertido en 3D.** Tacto suave. Disponible para el encendedor BIC® J25.
- DE >** 100 % personalisierte Hülle! **Ihr Logo wird in 3D gestaltet!** Mit Softtouch-Oberfläche. Verfügbar für BIC® J25-Feuerzeuge.
- IT >** Custodia 100% personalizzata! **Il tuo logo convertito in 3D.** Soffice al tatto. Disponibile per accendini BIC® J25.



100%

BIC® LIGHTERS

LIGHTER CASES



100%

2395

A/C> max. 6 colours

MOQ: 1200 u.



Standard Packaging: box for 50 units

See details p. 195

Please contact your Customer Service Representative for further details.



Pocket Ashtray & Pocket Ashtray Kraft



EN > Keep the environment cleaner with this practical and useful accessory! The BIC® Pocket Ashtray features a **fireproof lining** and sturdy button clasp that **locks in odours** while allowing users to extinguish up to five lit cigarettes. Also available in soft-touch kraftboard material.

FR > Maintenez l'environnement propre avec cet accessoire pratique et utile. Le BIC® Pocket Ashtray est doté d'un **revêtement intérieur anti-feu** et d'un système de fermeture résistant à bouton-poussoir qui **bloque les odeurs** et, à la fois, qui permet d'éteindre jusqu'à 5 cigarettes. Aussi disponible dans une matière craft au touché soft.

ES > ¡Mantén tu entorno más limpio con este práctico y útil accesorio! El BIC® Pocket Ashtray tiene un **revestimiento ignifugo** en el interior y un cierre resistente de botón que **bloquea el olor** permitiendo al usuario apagar hasta 5 cigarrillos encendidos. También disponible en papel kraft de tacto suave.

DE > Halten Sie die Umwelt sauber mit diesem praktischen und sinnvollen Accessoire! Der BIC® Pocket Ashtray schließt dank des **feuerfesten Futters** und des stabilen Druckverschlusses den Geruch ein. Bis zu 5 Zigaretten können darin ausgelöscht werden. Auch aus Kraftpapier mit Softtouch-Oberfläche erhältlich.

IT > Mantieni pulito l'ambiente con questo pratico e utile accessorio! Il BIC® Pocket Ashtray ha un **rivestimento ignifugo** e una solida chiusura a bottone che **trattiene gli odori**, e consente così di spegnere fino a cinque sigarette. Mantieni pulito l'ambiente con questo pratico e utile accessorio!

6 different shapes!

Environmentally friendly image



3850



3851

Reusable & hermetic



3850
Pocket Ashtray
3851
Pocket Ashtray Kraft

A > max. 5 colours



FR > Image respectueuse de l'environnement. Réutilisable et hermétique. 6 différentes formes!
ES > Imagen respetuosa con el medio ambiente. Reutilizable y hermético. ¡6 formas distintas!

DE > Umweltfreundliches Image Wiederverwendbar & hermetisch. 6 verschiedene Formen!
IT > Immagine eco-friendly. Riutilizzabile ed ermetico. 6 differenti forme!

Please contact your Customer Service Representative for further details.

3850 MOQ: 5000 u.
3851 MOQ: 10000 u.

500
± 5.5 Kg*

*Inner packaging: Each BIC® Pocket Ashtray comes in an individual cellophane packaging.

OTHER PRODUCTS

BIC® LIGHTERS

FOR MEN

229 BIC® Comfort Twin

230 BIC® Flex3

231 BIC® Flex4 Comfort

FOR WOMEN

233 BIC® Comfort 2 Lady

234 BIC® Pure 3® Lady

235 BIC® Soleil® Bella® Lady



SHIVERS

 **FOR MEN**



BIC® SHAVERS

FOR MEN



Comfort Twin

- EN >** 2 blade shaver, affordable and practical.
- FR >** Rasoir à 2 lames, pratique et abordable.
- ES >** Maquinilla de 2 hojas, jasequible y práctica!
- DE >** 2-Klingen-Rasierer, erschwinglich und praktisch.
- IT >** Rasoio a 2 lame, conveniente e pratico.

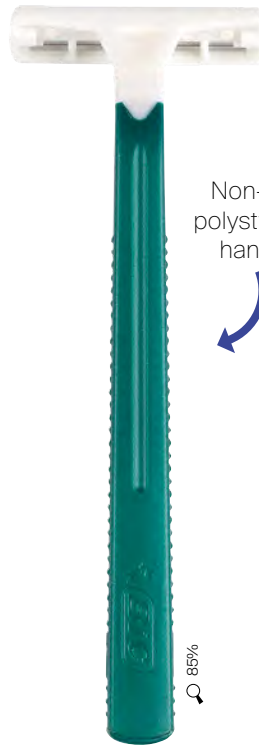

Non-slip polystyrene handle

2 blades

Large lubricating strip with aloe vera, vitamin A and E

Fixed and narrow head

Choice of packaging:

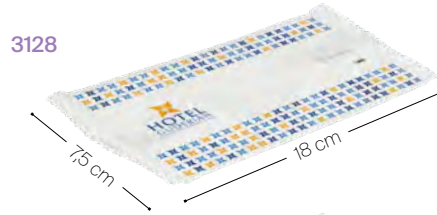

3128

75 cm x 18 cm

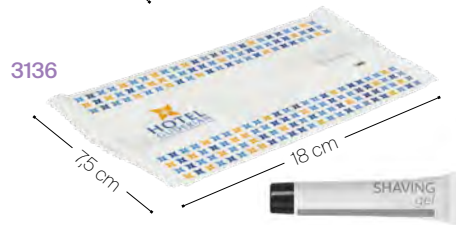

3136

75 cm x 18 cm



3122

4,3 cm x 11,6 cm x 2 cm



3134

4,3 cm x 11,6 cm x 2 cm

3128
BIC® Comfort Twin in personalized flow pack

3136
BIC® Comfort Twin with gel in personalized flow pack

3122
BIC® Comfort Twin in personalized box

3134
BIC® Comfort Twin with gel in personalized box

A/B > DG: 4CP

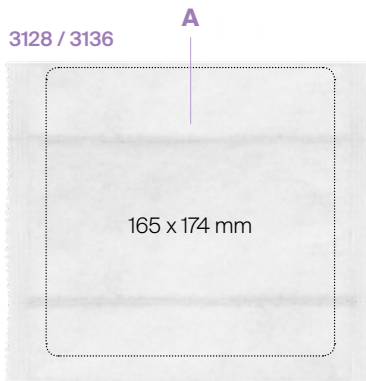

3128 / 3136

165 x 174 mm

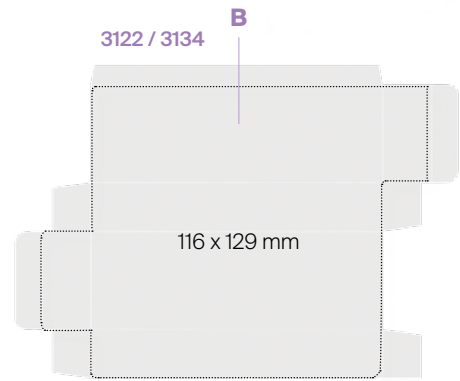

3122 / 3134

116 x 129 mm

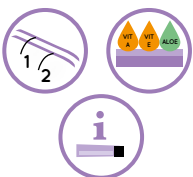

- FR >**
- 2 lames
 - Grande bande lubrifiante à l'aloë vera et aux vitamines A et E
 - Tête fixe étroite
 - Manche anti-dérapant en polystyrène

- ES >**
- 2 hojas
 - Gran banda lubricante con aloe vera, vitaminas A y E
 - Cabezal fijo y estrecho
 - Mango antideslizante de poliestireno

- DE >**
- 2 Klingen
 - Großer Gleitstreifen mit Aloe Vera, Vitamin A und E
 - Fester schmaler Rasurkopf
 - Rutschfester Polystyren-Griff

- IT >**
- 2 lame
 - Ampia striscia lubrificante con aloe vera, vitamina A ed E
 - Testa del rasoio rigida e stretta
 - Impugnatura antiscivolo in polistirene

MOQ: 500 u.



Additional BIC® Shaver models and services under request



EN > 3 moveable blade shaver, close and soft shave.

FR > Rasoir à 3 lames mobiles, pour un rasage de près, en douceur.

ES > Maquinilla con 3 hojas móviles. Afeitado apurado y suave.

DE > 3 bewegliche Klingen für glatte und sanfte Rasur.

IT > Rasoio con 3 lame mobili per una rasatura scorrevole e precisa.



Choice of packaging:

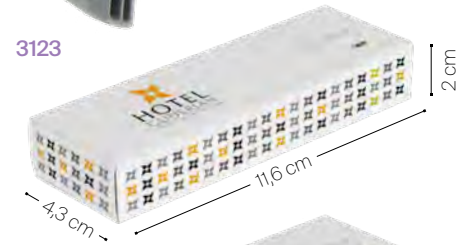
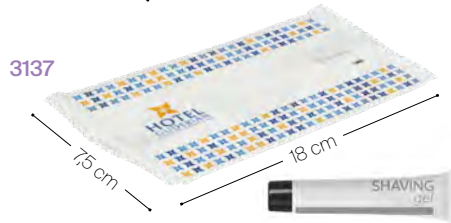
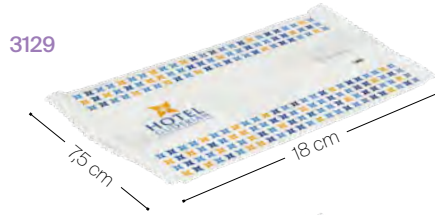

- 3129** BIC® Flex3 in personalized flow pack
- 3137** BIC® Flex3 with gel in personalized flow pack
- 3123** BIC® Flex3 in personalized box
- 3135** BIC® Flex3 with gel in personalized box

A/B > DG: 4CP

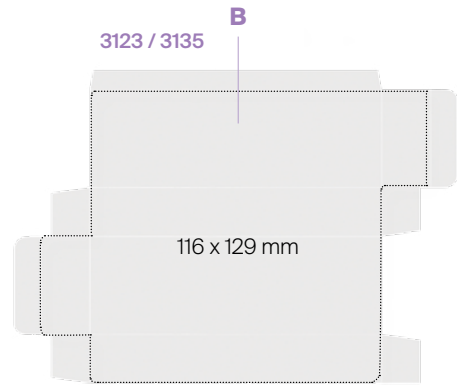
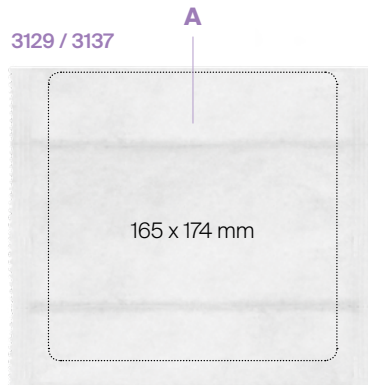

- FR >**
- Grande barre de protection
 - Tête pivotante
 - Bande lubrifiante à l'aloë vera et à la vitamine E
 - 3 lames mobiles
 - Manche incurvé avec zone de préhension Soft Grip

- ES >**
- Gran barra de protección
 - Cabezal pivotante
 - Banda lubricante con aloe vera y vitamina E
 - 3 hojas móviles
 - Mango curvo y suave

- DE >**
- Großer Schutzstreifen
 - Beweglicher Kopf
 - Gleitstreifen mit Aloe Vera und Vitamin E
 - 3 bewegliche Klingen
 - Geschwungener Soft-Griff

- IT >**
- Ampia barretta di sicurezza
 - Testa pivotante
 - Striscia lubrificante con aloe vera e vitamina E
 - 3 lame mobili
 - Impugnatura morbida curva
 - Testa del rasoio rigida e sottile

MOQ: 500 u.



Additional BIC® Shaver models and services under request



Flex4 Comfort

EN > Premium 4 moveable blade shaver, ultra-close soft shave and heavy handle.

FR > Rasoir haut de gamme à 4 lames mobiles et manche lourd, pour un rasage de très près, en douceur.

ES > Maquinilla premium con 4 hojas móviles, afeitado ultra-apurado y mango de fácil manejo.

DE > Premiumrasierer mit vier beweglichen Klingen und schwerem Griff für ultraglatte, softe Rasur.

IT > Rasoio premium con 4 lame mobili, per una rasatura morbida e ultra-precisa e con un'impugnatura di facile utilizzo.



Choice of packaging:

3130

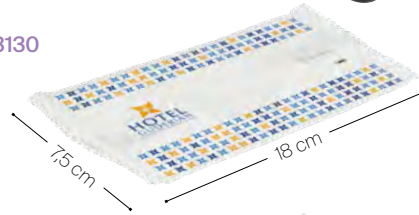

3144

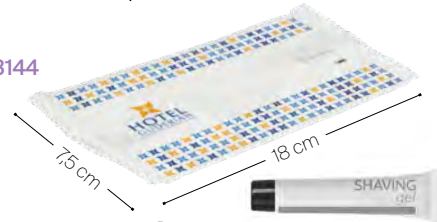

3124



3140



3130 / 3144



3124 / 3140

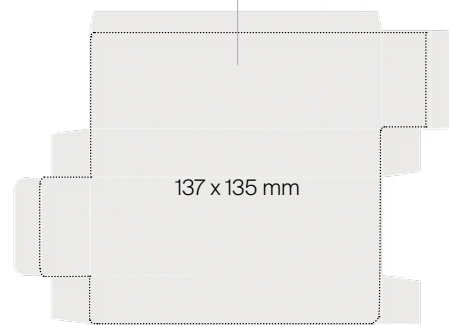

3130
BIC® Flex4 Comfort in personalized flow pack

3144
BIC® Flex4 Comfort with gel in personalized flow pack

3124
BIC® Flex4 Comfort in personalized box

3140
BIC® Flex4 Comfort with gel in personalized box

A/B > **DG: 4CP**

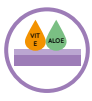

- FR** >
- Grande barre de protection
 - Tête pivotante
 - Bande lubrifiante à l'aloë vera et à la vitamine E
 - 4 lames mobiles
 - Manche ergonomique lourd, avec zone de préhension caoutchoutée

- ES** >
- Gran barra de protección
 - Cabezal pivotante
 - Banda lubricante con aloe vera y vitamina E
 - 4 hojas móviles
 - Mango de fácil manejo con agarre de goma

- DE** >
- Großer Schutzstreifen
 - Schwingkopf
 - Gleitstreifen mit Aloe Vera und Vitamin E
 - 4 bewegliche Klingen
 - Komfortabler schwerer Griff mit Gummierung

- IT** >
- Ampia barretta di sicurezza
 - Testa pivotante
 - Striscia lubrificante con aloe vera e vitamina E
 - 4 lame mobili
 - Impugnatura comoda e pesante con gomma antiscivolo

MOQ: 500 u.



Additional BIC® Shaver models and services under request

www.bicgraphic.eu

231

FOR MEN
BIC® SHAVERS

 **FOR WOMEN**

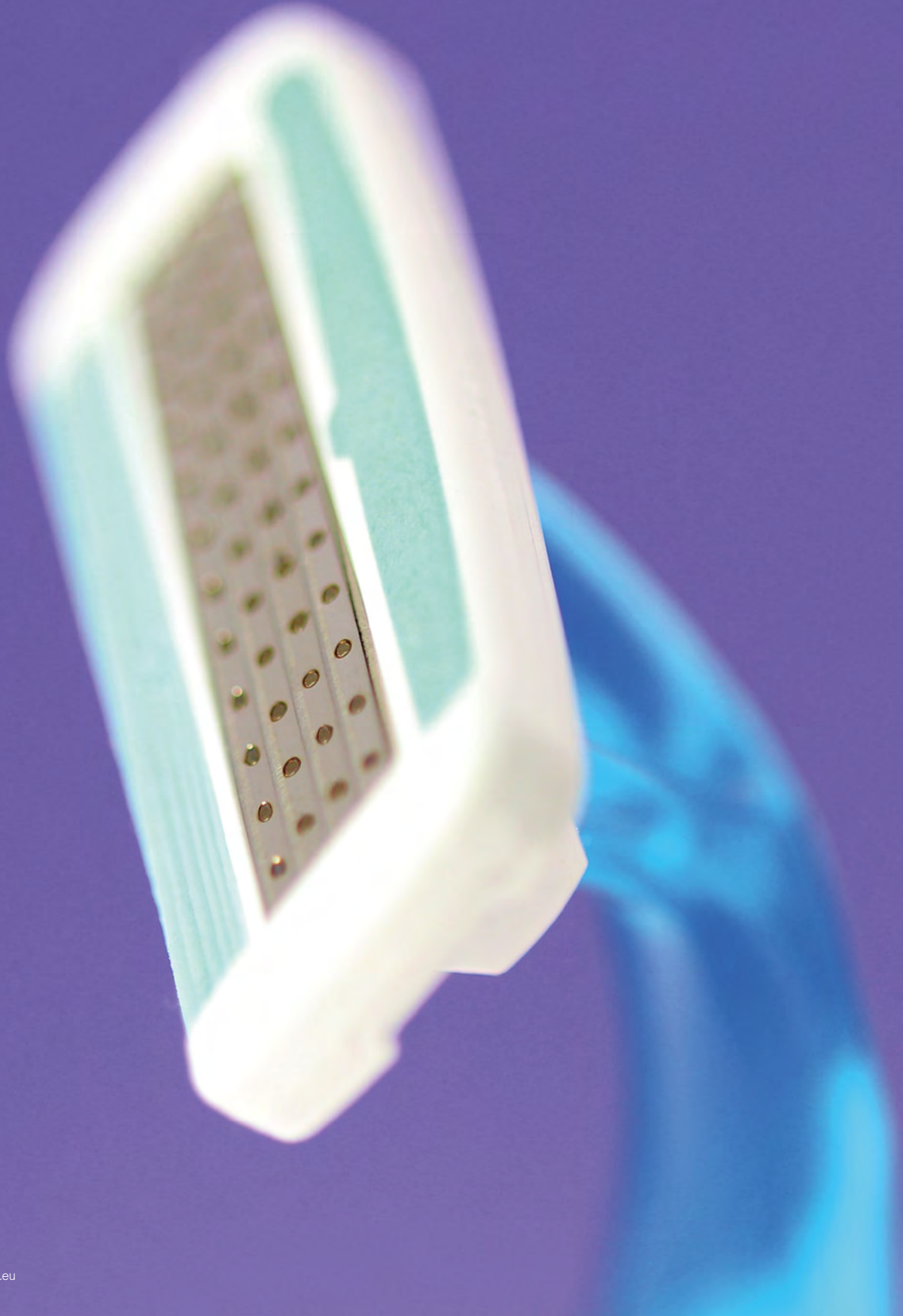

BIC® SHAVERS

FOR WOMEN



Comfort 2 Lady

EN > Feminine 2 blade shaver, affordable and practical.

FR > Rasoir à 2 lames pour femme, pratique et abordable.

ES > Maquinilla de 2 hojas para mujer, asequible y práctica.

DE > Femininer 2-Klingen-Rasierer, erschwinglich und praktisch.

IT > Rasoio femminile a 2 lame, conveniente e pratico.



Choice of packaging:

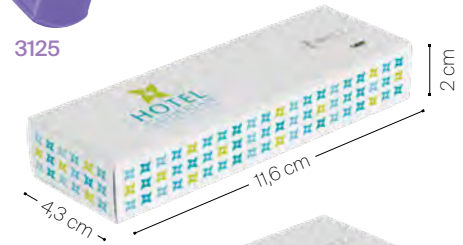
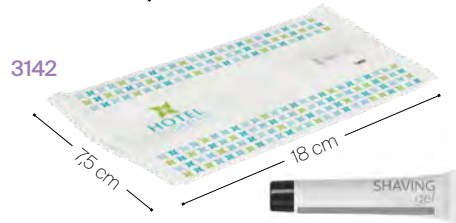
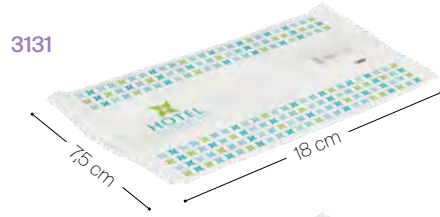

3131
BIC® Comfort 2 Lady in personalized flow pack

3142
BIC® Comfort 2 Lady with gel in personalized flow pack

3125
BIC® Comfort 2 Lady in personalized box

3138
BIC® Comfort 2 Lady with gel in personalized box

A/B > DG: 4CP

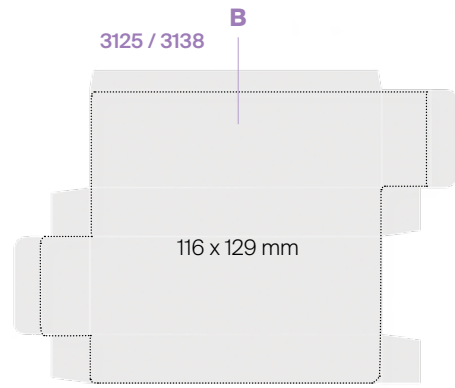
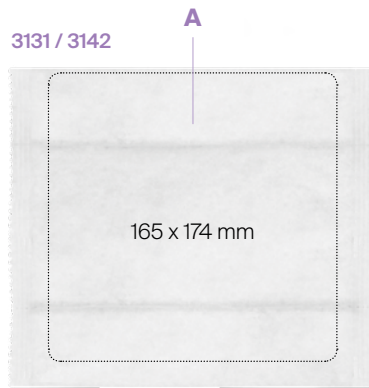

- FR >**
- 2 lames
 - Grande bande lubrifiante à la vitamine E
 - Tête fixe étroite
 - Manche léger anti-dérapant

- ES >**
- 2 hojas
 - Banda lubricante con vitamina E
 - Cabezal fijo y estrecho
 - Mango antideslizante

- DE >**
- 2 Klingen
 - Großer Gleitstreifen mit Vitamin E
 - Fester, schmaler Rasurkopf
 - Leichter rutschfester Griff

- IT >**
- 2 lame
 - Ampia striscia lubrificante con vitamina E
 - Testa del rasoio rigida e stretta
 - Impugnatura antiscivolo leggera

MOQ: 500 u.



Additional BIC® Shaver models and services under request

www.bicgraphic.eu



Pure 3[®] Lady

- EN >** Feminine 3 blade shaver, efficient shave at an affordable price.
- FR >** Rasoir à 3 lames pour femme, pour un rasage efficace à un prix abordable.
- ES >** Maquinilla de 3 hojas para mujer, depilación eficiente a un precio asequible.
- DE >** Femininer 3-Klingen-Rasierer für effiziente Rasur zum erschwinglichen Preis.
- IT >** Rasoio femminile a 3 lame, per una rasatura efficiente a un prezzo conveniente.



Choice of packaging:

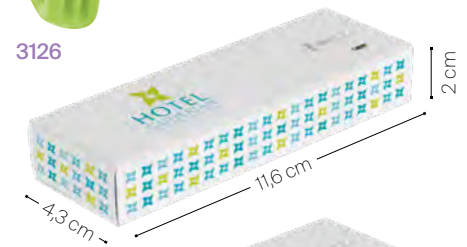
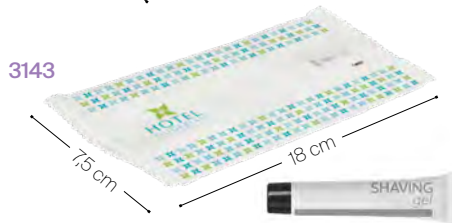
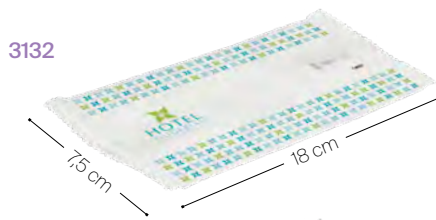

- 3132** BIC[®] Pure[®] Lady in personalized flow pack
- 3143** BIC[®] Pure 3[®] Lady with gel in personalized flow pack
- 3126** BIC[®] Pure[®] Lady in personalized box
- 3139** BIC[®] Pure 3[®] Lady with gel in personalized box

A/B > DG: 4CP

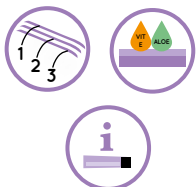
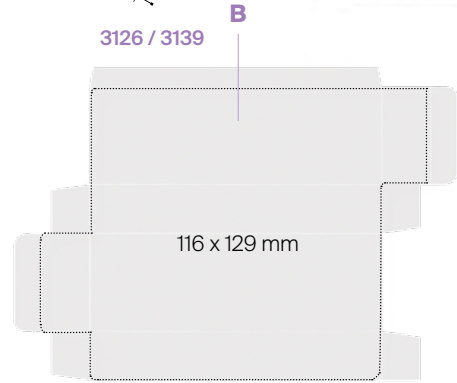
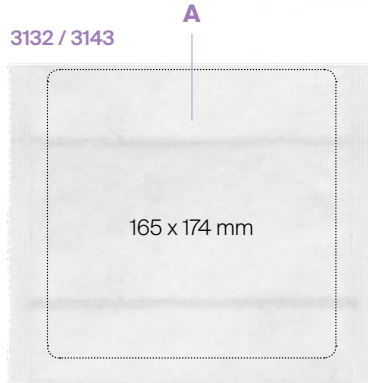

- FR >**
- Tête fixe
 - Bande lubrifiante à l'aloé vera
 - 3 lames
 - Manche droit avec stries anti-dérapantes

- ES >**
- Cabezal fijo
 - Banda lubricante con aloé vera
 - 3 hojas
 - Mango recto con rebordes antideslizantes

- DE >**
- Fester Kopf
 - Gleitstreifen mit Aloe Vera
 - 3 Klingen
 - Gerader Griff mit Antirutsch-Schlitz

- IT >**
- Testa rigida
 - Striscia lubrificante con aloé vera
 - 3 lame
 - Impugnatura dritta con rilievi antiscivolo

MOQ: 500 u.





Soleil® Bella® Lady

EN > Premium feminine 4 moveable blade shaver, ultra-smooth close shave.

FR > Rasoir haut de gamme à 4 lames mobiles pour femme, pour un rasage précis tout en douceur.

ES > Maquinilla premium de 4 hojas móviles para mujer, depilación ultra suave y apurada.

DE > Femininer Premium-Rasierer mit 4 beweglichen Klingen für ultrasofte, glatte Rasur.

IT > Rasoio femminile premium con 4 lame mobili, per una rasatura precisa e ultra-morbida.



Choice of packaging:

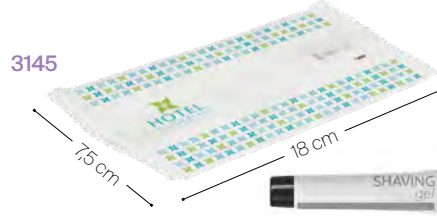
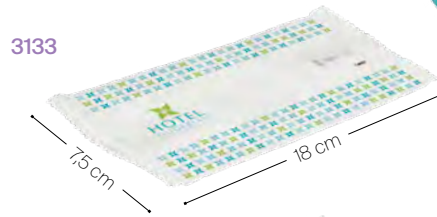

3133
BIC® Soleil® Bella® Lady in personalized flow pack

3145
BIC® Soleil® Bella® Lady with gel in personalized flow pack

3127
BIC® Soleil® Bella® Lady in personalized box

3141
BIC® Soleil® Bella® Lady with gel in personalized box

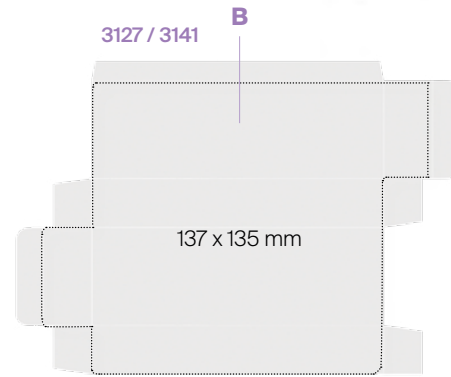
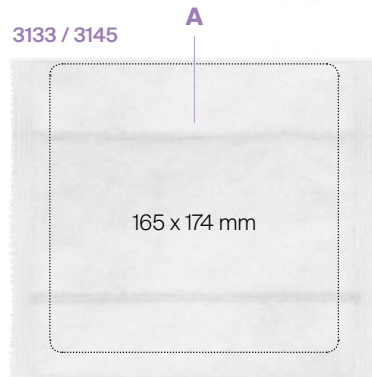

A/B > DG: 4CP



FR >

- Tête pivotante
- Bande lubrifiante au lait de coco
- 4 lames mobiles
- Grande barre de protection
- Manche ergonomique incurvé avec zone de préhension Soft Grip

ES >

- Cabezal pivotante
- Banda lubricante con leche de coco
- 4 hojas móviles
- Gran barra de protección
- Mango ergonómico con agarre de goma

DE >

- Schwingkopf
- Gleitstreifen mit Kokosnussmilch
- 4 bewegliche Klingen
- Großer Schutzstreifen
- Komfortabler, geschwungener Soft-Griff

IT >

- Testa pivotante
- Striscia lubrificante con latte di cocco
- 4 lame mobili
- Ampio margine di sicurezza
- Impugnatura comoda e curva con gomma antiscivolo

MOQ: 500 u.



Additional BIC® Shaver models and services under request

BACKPACKS

239 BIC® Drawstring Backpack

240 BIC® Classic Backpack

ACCESSORIES

241 BIC® Multi-use Pouch



BAGS

Bic Bags



BIC® BAGS

BACKPACKS



Drawstring Backpack

EN > Modern design and lightweight drawstring backpack for basic needs. **Comfortable, functional, high quality and ready to personalize it with your logo.**

FR > Sac à dos léger à cordon coulissant pour vos objets de tous les jours. Design moderne. **Confortable, fonctionnel, haute qualité, à personnaliser avec votre logo.**

ES > Mochila de cordones ligera y con diseño moderno para necesidades básicas. **Cómoda, funcional, de alta calidad y preparada para personalizarla con tu logo.**

DE > Leichtgewichtiger Kordelzugrucksack für den Alltag im modernen Design. **Komfortabel und funktionell in hochwertiger Qualität. Es fehlt nur noch Ihr Logo!**

IT > Zainetto con cordoncini leggero e dal design moderno per le necessità di base. **Comodo, funzionale, di elevata qualità e pronto a essere personalizzato con il tuo logo.**



Adjustable straps



41 cm

3450

3453

32,5 cm

32,5 cm

3450
A > SP: max. 2 colours

3453
B > OT: 4CP



FR > • Anse avec détail en PU
• Etiquette BIC® porte-nom
• Sangles réglables
• Logo BIC® en silicone
• Doublure avec logo BIC®
• Fermeture-éclair réfléchissante décorative

ES > • Asa con contraste de PU
• Etiqueta BIC® para el nombre
• Asas ajustables
• Logo BIC® de silicona
• Forro interior con el logo BIC®
• Cremallera con banda reflectante decorativa

DE > • Tragegriff mit kontrastierendem PU-Element
• BIC®-Namensschild
• Verstellbare Tragegurte
• BIC®-Logo aus Silikon
• Futter mit BIC®-Logo
• Dekorativer, reflektierender Reißverschluss

IT > • Maniglia con inserti in PU
• Targhetta portanome con logo BIC®
• Spallacci regolabili
• Logo BIC® in silicone
• Fodera con logo BIC®
• Cerniera riflettente decorativa

MOQ: 25 u.
3450 / 3453





Classic Backpack

EN > Multi-function backpack with diamond pattern. **Main compartment with padded pocket, organizer and additional front pocket with wide imprint area.** Many features in a single product crafted from premium durable polyester.

FR > Sac à dos multifonction avec motifs en forme de losanges. **Compartment principal avec poche rembourrée, organisateur et poche frontale avec grande zone d'impression.** Un produit unique multifonction en polyester durable haute qualité.

ES > Mochila multifunción con patrón en forma de diamante. **Compatimento principal con un bolsillo acolchado, un organizador y un bolsillo adicional frontal con una amplia área de impresión.** Muchos detalles en un producto elaborado con el mejor y duradero polyester.

DE > Multifunktionaler Rucksack mit Diamantmuster. **Hauptfach mit gepolsterter Tasche, Organizer und zusätzlicher Fronttasche mit großer Druckfläche.** Viele Details in einem Produkt aus langlebigem Premium-Polyester.

IT > Zainetto multifunzionale con motivo a rombi. **Scomparto principale con tasca imbottita, organizzatore e tasca frontale supplementare con ampia area di stampa.** Molti dettagli in un unico prodotto realizzato in resistente poliestere di qualità.



Decorative reflective zipper



Padded pocket and useful organizer



BIC® name tag

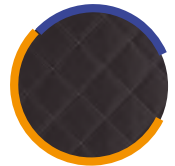

Diamond pattern



Silicone BIC® logo



Lining with BIC® logo

Useful strap for placing on a trolley

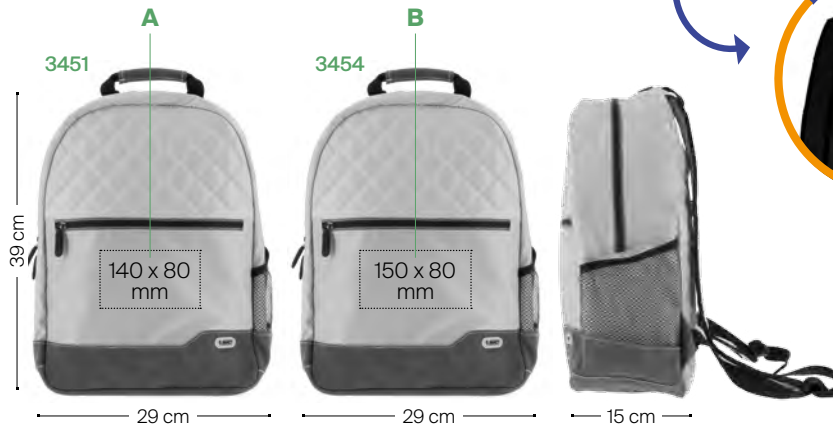

3451
A > SP: max. 2 colours

3454
B > OT: 4CP

02 03 12
25 59



FR >

- Fermeture-éclair réfléchissante décorative
- Poche rembourrée et organisateur très utile
- Étiquette BIC® porte-nom
- Motifs en forme de losanges
- Logo BIC® en silicone
- Doubleure avec logo BIC®
- Sangle très pratique pour suspendre le sac à un chariot

ES >

- Cremallera con banda reflectante decorativa
- Bolsillo acolchado y práctico organizador
- Etiqueta BIC® para el nombre
- Patrón en forma de diamante
- Logo BIC® de silicona
- Fondo interior con el logo BIC®
- Práctica correa para ponerla en una trolley

DE >

- Dekorativer reflektierender Reißverschluss
- Gepolsterte Tasche und praktischer Organizer
- BIC®-Namensschild
- Diamantmuster
- BIC®-Logo aus Silikon
- Futter mit BIC®-Logo
- Praktisches Band zur Befestigung am Trolley

IT >

- Cerniera riflettente decorativa
- Tasca imbottita e utile organizer
- Targhetta portanome con logo BIC®
- Motivo a rombi
- Logo BIC® in silicone
- Fodera con logo BIC®
- Cinghie per il fissaggio su un trolley

MOQ: 25 u.
3451 / 3454

25
±8,7 kg



Multi-use Pouch

EN > The useful accessories pouch with a registered design and large print area. **Personalize your multi-use pouch with your logo.**

FR > Trousse d'écolier avec design breveté et une large zone d'impression. **Choisissez votre trousse multifonction et personnalisez-la avec votre logo.**

ES > Práctico estuche multiusos con un diseño registrado y una amplia area de impresión. **Adquiere tu estuche multiusos y personalízalo con tu logo.**

DE > Das praktische Schultäppchen mit eingetragem Design und großer Druckfläche. **Sichern Sie sich Ihr vielseitig einsetzbares Täppchen und personalisieren Sie es mit Ihrem Logo!**

IT > Utile astuccio con design registrato e ampia area di stampa. **Scegli il tuo astuccio multiuso e personalizzalo con il tuo logo.**



3452
A > SP: max. 1 colour

3455
B > OT: 4CP

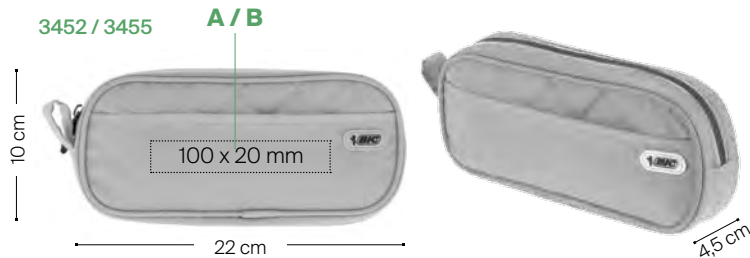

FR > • Fermeture-éclair réfléchissante décorative
• Motifs en forme de losanges
• Logo BIC® en silicone
• Étiquette BIC® porte-nom
• Doublure avec logo BIC®

ES > • Cremallera con banda reflectante decorativa
• Patrón en forma de diamante
• Logo BIC® de silicona
• Etiqueta BIC® para el nombre
• Forro interior con el logo BIC®

DE > • Dekorativer reflektierender Reißverschluss
• Diamantmuster
• BIC®-Logo aus Silikon
• BIC®-Namensschild
• Futter mit BIC®-Logo

IT > • Cerniera riflettente decorativa
• Motivo a rombi
• Logo BIC® in silicone
• Targhetta portanome con logo BIC®
• Fodera con logo BIC®

MOQ: 25 u.
3452 / 3455





T'nB®

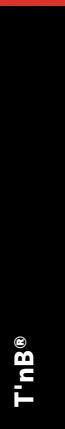



Live in earphones



EN > Stereo earphones with hands-free kit.

The cable is 120 cm long and sends excellent quality sound to your ear buds. Includes hard case with zip.

FR > Écouteurs stéréo avec kit mains libres.

Le câble mesure 120 cm de long et dirige le son d'une très grande qualité vers les écouteurs. Un étui dur avec fermeture à glissière est inclus.

ES > Auriculares estéreo con kit de manos libres.

El cable mide 120 cm de largo y dirige el sonido con alta calidad hacia los auriculares. Incluye estuche rígido con cierre de cremallera.

DE > Stereo-Ohrhörer mit Freisprecheinrichtung.

120 cm langes Kabel, das die überragende Soundqualität an die Ohrstecker überträgt. Inklusive verstärkter Tasche mit Reißverschluss.

IT > Auricolari stereo con kit vivavoce.

Il cavo ha una lunghezza di 120 cm e convoglia il suono in alta qualità verso gli auricolari. Include una custodia rigida dotata di chiusura con cerniera.

Built-in hands-free kit to pick up the phone while on the go



09663

A > PD: max. 1 colour

20-20.000	16	105	9 mm NdFeB
-----------	----	-----	------------



FR > Kit mains libres intégré pour décrocher votre téléphone en marchant

ES > Kit manos libres integrado para descolgar el teléfono en marcha

DE > Eingebaute Freisprecheinrichtung, um Telefonate unterwegs annehmen zu können

IT > Kit vivavoce integrato per rispondere al telefono in movimento

MOQ: 10 u.



± 75 Kg



Sport earphones with mic

EN > Sport earphones with microphone. Compatible with all smartphones / MP3 players, etc.

These sport earphones can be used in all sports activities, thanks to its flexible earhole system.

FR > Écouteurs de sport avec microphone. Compatibles avec tous les smartphones, lecteurs MP3, etc.

Ces écouteurs de sport ont été conçus pour toutes les activités sportives grâce au système d'attache pour les oreilles.

ES > Auriculares de deporte con micrófono. Compatibles con todos los smartphones, reproductores MP3, etc.

Estos auriculares de deporte están pensados para todas las actividades deportivas gracias al sistema de enganche para las orejas.

DE > Sport-Ohrhörer mit Mikrophon. Kompatibel mit allen Smartphones / MP3-Playern etc.

Diese Sport-Ohrhörer können bei allen sportlichen Aktivitäten eingesetzt werden, dank des flexiblen Ohrbügel-Systems.

IT > Auricolari con microfono per fare sport. Compatibili con tutti gli smartphone, lettori MP3, ecc.

Questi auricolari, ideali per lo sport, sono adatti a tutte le attività sportive grazie al sistema dotato di un archetto che avvolge l'orecchio.

Water resistant and built-in hands-free kit



09657
A > PD: max. 1 colour

20-20.000	30	108	9 mm NdFeB	
-----------	----	-----	------------	--

EARPHONES
T'nB®



FR > Résistant à l'eau et avec un kit mains libres intégré

ES > Resistente al agua y con kit de manos libres integrado

DE > Wasserabweisend mit eingebauter Freisprecheinrichtung

IT > Resistente all'acqua con kit vivavoce integrato

MOQ: 10 u. 200
± 5 Kg



Flat Bluetooth® earphones

EN > Featuring a universal built-in microphone and volume control function, these Bluetooth® 4.1 flat earphones are both stylish and ultra-functional. Enjoy your music playlists every day without a cable getting in the way. You can also take a call when your device is in your pocket.

FR > Avec un microphone universel incorporé et une fonction de contrôle de volume, ces écouteurs Bluetooth® 4.1 Flat sont à la fois élégants et ultra-fonctionnels. Profitez au quotidien de votre liste de lecture sans être gêné par aucun câble. Et, très important, vous pouvez répondre à un appel sans avoir à sortir le portable de votre poche.

ES > Con un micrófono universal integrado y función de control de volumen, estos auriculares Bluetooth® 4.1 Flat son elegantes a la vez que ultrafuncionales. Disfruta de tu lista de reproducción en tu día a día sin que ningún cable se interponga en tu camino. Destaca la posibilidad de responder a una llamada sin sacar el móvil del bolsillo.

DE > Mit ihrem integrierten Universalmikrofon und Lautstärkereger sind diese flachen Bluetooth® 4.1 Ohrhörer sowohl stylish als auch ultrafunktionell. Genießen Sie Ihre Playlists im täglichen Leben ohne störendes Kabel. Sie können auch Anrufe entgegennehmen, während das Gerät in Ihrer Tasche verstaut ist.

IT > Con il microfono universale integrato e la funzione di controllo del volume, questi auricolari Bluetooth® 4.1 Flat sono eleganti e al contempo estremamente funzionali. Goditi la tua playlist in ogni momento senza il fastidio del cavo. Potrai addirittura rispondere a una chiamata senza estrarre il cellulare dalla tasca.

Bluetooth® 4.1 earphones with built-in hands-free kit and up to 6 hours of battery life

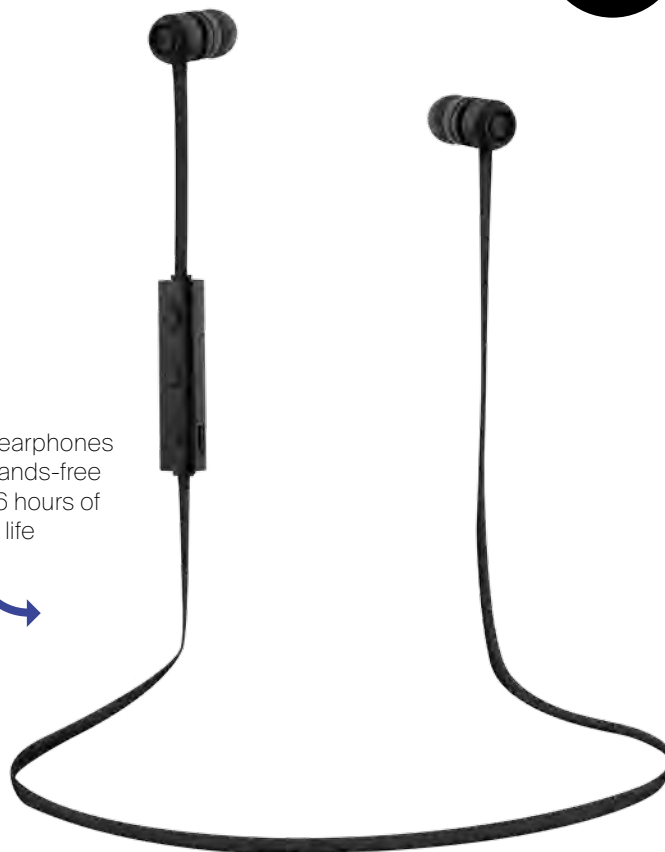

09676
A > PD: max. 1 colour

20-20.000	16	90	9 mm NdFeB	10 m	6h
-----------	----	----	------------	------	----



FR > Écouteurs Bluetooth® 4.1 avec kit mains libres incorporé et jusqu'à 6 heures d'autonomie

ES > Auriculares Bluetooth® 4.1 con kit manos libres integrado y hasta 6 horas de autonomía

DE > Bluetooth® 4.1 Ohrhörer mit integrierter Freisprecheinrichtung und bis zu 6 Stunden Leistung

IT > Auricolari Bluetooth® 4.1 con vivavoce integrato e fino a 6 ore di autonomia

MOQ: 10 u. 160 ± 12 Kg



Legend headphones



EN > A vintage atmosphere for this new range of headphones with a padded fabric arch, snap buttons, velvet felt foams for listening comfort, aluminum pars, and a braided nylon cable. **Clear and precise sound, allowing you to enjoy your favorite music for hours.**

FR > Une atmosphère vintage pour cette nouvelle gamme de casque, avec un arceau rembourré, des boutons pression, des mousses en feutrine velours pour un confort d'écoute, des pars en aluminium, et un câble en nylon tressé. **Un son clair et précis pour vous permettre d'apprécier votre musique favorite pendant des heures.**

ES > Un estilo vintage en la nueva gama de auriculares con un arco de tela acolchada, botones a presión, espumas de fieltro de terciopelo para comodidad auditiva, piezas de aluminio y un cable de nylon trenzado. **Sonido claro y preciso que le permite disfrutar de su música favorita durante horas.**

DE > Einen Hauch von Vintage verkörpert die neue Kopfhörer-Serie mit dem textilummantelten Bügel, Druckknöpfen, Ohrmuscheln mit Samtpolstern für komfortables Hörerlebnis und einem geflochtenen Nylonkabel. **Klarer und präziser Sound. Lauschen Sie Ihrer Lieblingsmusik - stundenlang!**

IT > Un'atmosfera vintage per questa nuova gamma di cuffie con arco in tessuto imbottito, bottoni a pressione, padiglioni in schiuma ricoperta in velluto per la massima comodità di ascolto, parti in alluminio e un cavo in nylon intrecciato. **Un suono nitido e preciso che ti permette di ascoltare la tua musica preferita per ore.**



Vintage atmosphere with the padded velvet ear cushions and reinforced metal structure

60%



09694
A > BP: left full-colour
B > BP: right full-colour

20-20.000	32	107	40 mm NdFeB	1,5 m
-----------	----	-----	-------------	-------

HEADPHONES

T'nB®



FR > Atmosphère vintage avec coussins velours rembourrés, et structure métal renforcée

ES > Ambiente vintage por sus almohadillas de terciopelo acolchado y estructura metálica reforzada

DE > Vintage-Atmosphäre mit samtgepolsterten Ohrmuscheln und verstärktem Metallgehäuse.

IT > Un'atmosfera vintage con imbottitura per orecchie ricoperta in velluto e struttura in metallo

MOQ: 10 u. 6 ±2,8 Kg



Kids headphones

EN > Stereo headphones for children. Sensitivity limited to 85 dB (EU regulations). Suitable for iPod®, MP3/MP4 players, mobile phones, DVD players and video game consoles.

FR > Écouteurs stéréo pour enfants. Sensibilité limitée à 85 dB (règlement européen). Conviennent à des iPod®, à des lecteurs MP3/MP4, à des téléphones portables, à des lecteurs de DVD et à des consoles de jeux.

ES > Auriculares estéreo para niños. Sensibilidad limitada a 85dB (Regulación Europea). Apto para iPod®, reproductores MP3/MP4, teléfonos móviles, reproductores de DVD y consolas de videojuegos.

DE > Stereo-Kopfhörer für Kinder. Auf 85 dB limitierte Empfindlichkeit (EU-Richtlinie). Passend für iPod®, MP3/MP4-Player, Mobiltelefone, DVD-Player und Video-Spielkonsolen.

IT > Cuffie stereo per bambini. Sensibilità limitata a 85 dB (normativa europea). Adatte per iPod®, lettori MP3/MP4, telefoni cellulari, lettori DVD e console per videogiochi.

Volume limited to 85 dB to keep hearing safe



09656

A > PD: max. 1 colour

B > PD: max. 1 colour

C > PD: max. 1 colour

20-20.000	32 Ω	85	27 mm NdFeB	1,1m
-----------	-------------	----	-------------	------



FR > Volume limité à 85 dB pour protéger les oreilles

ES > Volumen limitado a 85 dB para mantener los oídos a salvo

DE > Auf 85 dB begrenzte Lautstärke - schützt Kinderohren

IT > Volume limitato a 85 dB per evitare danni all'udito

MOQ: 10 u.

60
± 9,4 Kg

Be colour headphones

EN > Foldable and adjustable headphones that allow you to listen to all your favorite songs wherever you go with 120 cm cable. Sensitivity up to 105 dB that provides a deep bass and excellent sound quality. Built-in microphone to pick up the phone while on the go. Closed design to block noise from going in and out of the headphones.

FR > Écouteurs pliables et réglables qui vous permettent d'écouter vos chansons préférées, où que vous alliez, grâce au câble de 120 cm de long. Sensibilité jusqu'à 105 dB qui offre des basses profondes et une excellente qualité de son. Microphone incorporé pour décrocher le téléphone en marchant. Design fermé pour empêcher le bruit d'entrer et de sortir des écouteurs.

ES > Auriculares plegables y ajustables que te permiten escuchar tus canciones favoritas vayas donde vayas gracias a su cable de 120 cm de largo. Sensibilidad hasta 105 dB que proporciona bajos graves y una excelente calidad de sonido. Micrófono incorporado para descolgar el teléfono en marcha. De diseño cerrado para limitar el sonido que sale o entra de los auriculares.

DE > Zusammenklappbarer und verstellbarer Kopfhörer, mit dem Sie all Ihre Lieblingssongs mittels eines 120 cm-Kabels hören können. Mit Empfindlichkeit von bis zu 105 dB, liefert der Kopfhörer tiefe Bässe bei exzellenter Soundqualität. Integriertes Mikrofon um Telefonate unterwegs annehmen zu können. Geschlossenes Design, um Umweltgeräusche abzuschirmen und den Sound nicht nach außen dringen zu lassen.

IT > Cuffie con archetto pieghevole e regolabile che ti consentono di ascoltare le tue canzoni preferite ovunque andrai grazie al loro cavo lungo 120 cm. Sensibilità fino a 105 dB che garantisce bassi profondi e un'eccellente qualità del suono. Microfono incorporato per rispondere al telefono in movimento. Design che blocca i rumori impedendogli di entrare e uscire dalle cuffie.

Enjoy your music with its 105 dB of deep bass!



75%



09669
A > PD: max. 1 colour
B > PD: max. 1 colour

20-20.000	32	105	40 mm NdFeB
-----------	----	-----	-------------

HEADPHONES

T'nB®



FR > Profitez de votre musique avec ses 105 dB de sons graves et profonds!

ES > ¡Disfruta tu música con sus 105 dB de graves profundos!

DE > Genießen Sie Ihre Musik mit 105 dB tiefen Bässen!

IT > Goditi la tua musica preferita grazie ai 105 dB dei bassi più profondi!

MOQ: 10 u. 30
± 8,4 Kg



Active Noise Reduction headphones



EN > Premium stereo headset features active noise reduction technology to eliminate any noise barriers between you and your music. Discover a world without noise. With a single push of a button, the noises disappear to leave room for music. **Ideal for travellers, the Active noise reduction headset comes with an airplane adapter.** The supra-aural headset is foldable and its headphones are rotating.

FR > Casque stéréo premium avec technologie de réduction de bruits active pour éliminer tout obstacle sonore entre vous et votre musique. D'une simple pression sur un bouton, les bruits disparaissent pour laisser la place à la musique. **Idéal pour les voyageurs, le casque avec réduction de bruits Active est livré avec un adaptateur avion.** Le casque supra-aural est pliable et ses écouteurs sont rotatifs.

ES > Auriculares estéreo de primera calidad con tecnología de reducción de ruido activa para eliminar cualquier barrera de ruido entre tu música y tú. Descubre un mundo sin ruido. Con solo presionar un botón, los ruidos desaparecen para dejar espacio a la música. **Ideal para viajeros, los auriculares de reducción de ruido vienen con un adaptador de avión.** El auricular supra-aural es plegable y sus auriculares son giratorios.

DE > Premium Stereo-Kopfhörer mit aktiver Technologie zur Unterdrückung der Umgebungsgeräusche. Jedes störende Geräusch zwischen Ihnen und Ihrer Musik wird abgeschirmt. Entdecken Sie eine Welt ohne Lärm. Mit einem einzigen Knopfdruck lassen sich die Geräusche ausschalten, um Raum für Musik zu schaffen. **Ideal für Reisende: Das Active Noise Reduction-Headset ist mit einem Flugzeug-Adapter.** Das ohrauffliegende Headset ist faltbar, und die Hörmuscheln sind drehbar. Mitgeliefert wird ein abnehmbares Audiokabel.

IT > Cuffie stereo premium con tecnologia attiva di riduzione del rumore per eliminare qualunque disturbo tra te e la tua musica. Scopri un mondo senza rumore. Premendo semplicemente un bottone, i rumori spariscono per lasciare spazio alla musica. **Ideale per i viaggiatori, le cuffie con riduzione attiva del rumore, sono fornite di adattatore per aereo.** Le cuffie supra-aural sono ripieghevoli e hanno gli auricolari rotanti



Active noise cancelling technology and 1,5 m wireless headphones



09695

A > BP: full-colour

20-20.000	32	98	40 mm NdFeB	1,5 m	12h
-----------	----	----	-------------	-------	-----



FR > Technologie active de suppression de bruits, Bluetooth® mais si besoin cable de 1,5 m.

ES > Tecnología activa de bloqueo de ruido y auriculares inalámbrico de 1,5 m

DE > Kopfhörer mit aktiver Technologie zur Unterdrückung der Umgebungsgeräusche und 10 m Reichweite

IT > Tecnologia attiva di riduzione del rumore e cavo ausiliario da 1,5 m.

MOQ: 10 u.





Shine Bluetooth® headphones



4 in 1: Bluetooth® wireless, wired, FM radio and SD card!



75%

EN > Bluetooth® wireless 4-in-1 on-ear foldable headphones with built-in microphone. Up to 8 hours of clear sound provided with a 40 mm NdFeB magnet that can be played from four different sources: Bluetooth® 2.1 + EDR wireless, auxiliary cable included or SD card up to 16 GB. Adjustable padded headband and cushioned pads for maximum comfort.

FR > Écouteurs sans fil Bluetooth® 4 en 1, pliables et avec microphone incorporé. Profitez jusqu'à 8 heures de son net grâce à l'aimant NdFeB de 40 mm. Vous pouvez reproduire un son à partir de 4 sources différentes : Bluetooth® 2.1 + EDR sans câbles, avec le câble auxiliaire inclus, avec la radio FM et avec une carte SD jusqu'à 16 GB. Coussinets et arceau réglable rembourrés pour un plus grand confort.

ES > Auriculares inalámbricos Bluetooth® 4 en 1, plegables y con micrófono incorporado. Disfruta hasta 8 horas de 82 dB de sonido nítido gracias al imán NdFeB de 40 mm. Puede reproducir sonido de 4 fuentes distintas: Bluetooth® 2.1 + EDR sin cables, con el cable auxiliar incluido, con la radio FM o con una tarjeta SD de hasta 16GB. Almohadillas y diadema ajustable acolchadas para mayor confort.

DE > Kabelloser Bluetooth® 4-in-1 faltbarer Kopfhörer mit integriertem Mikrofon. Bis zu 8 Stunden klaren 82 dB-Sounds, von einem 40 mm NdFeB-Magneten erzeugt, kann von vier verschiedenen Quellen angesteuert werden: kabellos mit Bluetooth® 2.1+EDR, kabelgebunden mit beiliegendem Audiokabel, FM-Radio oder SD-Karte bis zu 16 GB. Verstellbarer, verstärkter Kopfbügel und gepolsterte Ohrmuscheln für maximalen Komfort.

IT > Cuffie wireless Bluetooth® 4 in 1, pieghevoli e con microfono integrato. Goditi fino a 8 ore di suono nitido a 82 dB, grazie al magnete dell'altoparlante al neodimio da 40 mm. Può riprodurre l'audio da 4 fonti diverse: dal Bluetooth® 2.1 + EDR wireless oppure collegato al cavo ausiliario incluso, dalla radio FM o dalla scheda SD fino a 16 GB. Padiglioni e archetto regolabile imbottiti per il massimo confort.

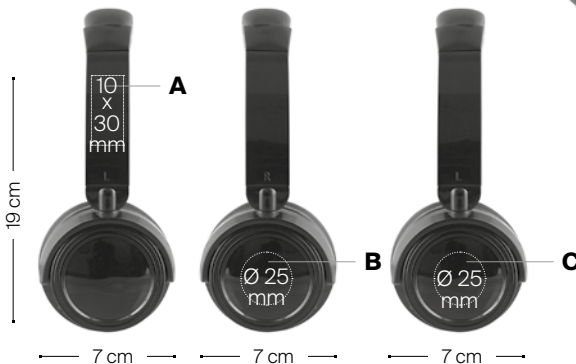

09675

A > PD: headband left
1 colour
B > BP: right
full-colour
C > BP: left
full-colour

24-24.000	32	82	40 mm NdFeB	8h
-----------	----	----	-------------	----



FR > 4 en 1: Bluetooth® sans fil, avec câble, radio FM et carte SD

ES > 4 en 1: Bluetooth® inalámbrico, con cable, radio FM y tarjeta SD

DE > 4-in-1: Bluetooth® kabellos, kabelgebunden, FM-Radio und SD-Karte!

IT > 4 in 1: Bluetooth® wireless, collegato al cavo, radio FM e scheda SD

MOQ: 10 u. 6 ±2.4 Kg

HEADPHONES

TnB®



Sport Bluetooth® headphones

EN > Sport Bluetooth® 4.0 headphones. Back of head. With advanced functions (track switch, volume control, pick up / hang up functions).

FR > Écouteurs de sport avec Bluetooth® 4.0 qui s'ajustent derrière la tête. Ils sont dotés de fonctions avancées (changement de chanson, contrôle de volume, raccrocher/décrocher).

ES > Auriculares deportivos con Bluetooth® 4.0. Se ajustan por detrás de la cabeza. Incluye funciones avanzadas (cambiar canción, controlar volumen, colgar/descolgar).

DE > Sport Bluetooth® 4.0 Kopfhörer mit Hinterkopf-Bügel. Mit Zusatzfunktionen (Track-Switch, Lautstärkeregler, Abheben / Auflegen).

IT > Cuffie sportive con Bluetooth® 4.0. Si regolano dietro la testa. Dispongono di funzioni avanzate (cambiare canzone, controllare il volume, rispondere/chiedere una chiamata).

Water resistant Bluetooth® 4.0 headphones with rechargeable battery



09667
A > PD: case top, max. 1 colour

20-20.000	32	105	30 mm NdFeB	10 m	10h	
-----------	----	-----	-------------	------	-----	--



FR > Écouteurs Bluetooth® 4.0 résistants à l'eau avec batterie rechargeable

ES > Auriculares Bluetooth® 4.0, resistentes al agua y con una batería recargable

DE > Wasserabweisender, leistungsstarker Bluetooth® 4.0-Kopfhörer mit aufladbarem Akku

IT > Auricolari Bluetooth® 4.0 resistenti all'acqua con batteria ricaricabile

MOQ: 10 u.

50
± 3.9Kg

Juke speakers 2.0

EN > Enhance the sound of the computer with this 2.0 multimedia speaker set with 4W RMS. **Compact and original design and USB easy plug and play connection.**

FR > Amplifiez le son de votre ordinateur avec ce set de haut-parleurs multimédia 2.0 d'une puissance de 4 W RMS. **Design compact et original, avec connexion USB rapide et facile.**

ES > Amplifica el sonido de tu ordenador con este set de altavoces multimedia 2.0 con potencia de 4W RMS. **Diseño compacto y original, conexión USB rápida y fácil.**

DE > Verbessern Sie den Sound Ihres Computers mit diesem 2.0 Multimedia-Lautsprecherset mit 4 W RMS. **Kompaktes und originelles Design und USB Plug&Play-Verbindung.**

IT > Amplifica il suono del tuo computer con questo set di altoparlanti multimediali 2.0, con una potenza di 4 W RMS. **Design compatto e originale con facile connessione USB "plug and play".**

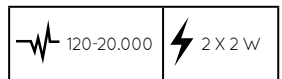
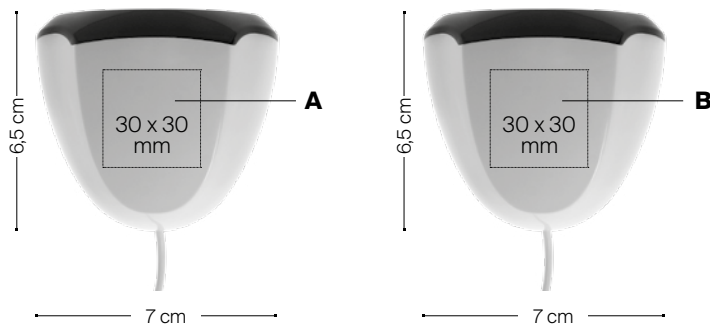

09660

A > PD: right top, max. 1 colour

B > PD: left top, max. 1 colour



FR > Son net dans un design compact!

ES > ¡Sonido nítido en un diseño compacto!

DE > Klarer Klang in kompaktem Design!

IT > Audio nitido in un design compatto!



MOQ: 10 u. 20
±3.7 Kg

SPEAKERS
T'nB®



ART speaker NEW



EN > Get seduced by this Bluetooth® speaker designed by T'nB®. **Combining design, trend, sound and technology, the ART collection will be your ideal companion at home or travelling.** Amplified quality sound with adjustable bass and treble distribution. Soft touch rubber coating design, a "must-have" for all trendy music addicts.

FR > Laissez-vous séduire par ce modèle d'haut-parleur Bluetooth® conçu par T'nB®. **Alliant à la fois design, tendance, son et technologie, la collection ART vous accompagnera partout chez vous ou en voyage !** Côté son, vous bénéficiez d'une qualité d'écoute amplifiée grâce à un aimant néodyme de 5 watts RMS, offrant une répartition réglable des basses et des aigus. Côté design et matière, ce haut-parleur joue la carte de l'esthétisme scandinave, avec un revêtement en caoutchouc, ultra doux au toucher.

ES > Déjate seducir por este altavoz Bluetooth® diseñado por T'nB®. **La colección ART es una combinación ideal de diseño, moda, sonido y tecnología que te acompañará a todas partes, ¡tanto en casa como en tus viajes!** Conseguirás una calidad de sonido amplificada gracias a sus 5W RMS con imán de neodimio y la regulación de agudos y graves ajustable. En cuanto a diseño y material, este altavoz juega un papel decorativo, referencia del espíritu escandinavo, con una superficie de goma que le proporciona un tacto ultra suave.

DE > Lassen Sie sich verführen von diesem Bluetooth®-Lautsprecher - designt von T'nB®. **Die ART-Collection vereint Design, Trend, Sound und Technologie und begleitet Sie zu Hause ebenso wie überall auf Reisen!** Sie erleben klangvollen Sound dank des 5 Watt-RMS-Neodym-Magneten mit Bass- und Höhenregulierung. Design und Materialien verkörpern skandinavischen Spirit und Lifestyle. Die rundum gummierte Oberfläche sorgt für ultrasoften Touch.

IT > Lasciati sedurre dal altoparlante Bluetooth® progettato da T'nB®. **La collezione ART è la perfetta sintesi di design, moda, suono e tecnologia e ti accompagnerà ovunque, a casa o in viaggio!** In merito al suono, puoi disporre di una qualità audio amplificata, grazie al magnete in neodimio da 5 watts RMS, con selezione regolabile dei bassi e degli alti. Per quanto riguarda il design e i materiali, questo altoparlante si gioca la carta dello stile, strizzando l'occhio allo spirito scandinavo, grazie al rivestimento in gomma, ultra morbido al tatto.

Bluetooth® technology,
3 hours autonomy,
universal compatibility.



75%

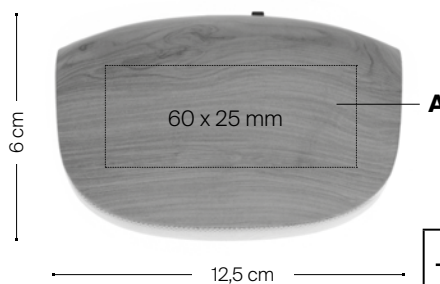

09696
A > BP: top, full-colour



FR > Technologie Bluetooth®, 3 heures d'autonomie, compatibilité universelle.

ES > Tecnología Bluetooth®, 3 horas de autonomía, compatibilidad universal.

DE > Bluetooth®-Technologie, 3 Stunden Autonomie, universelle Kompatibilität.

IT > Tecnologia Bluetooth®, 3 ore di autonomia, compatibilità universale.

MOQ: 10 u.

30

± 99 Kg

Sport Bluetooth® speaker ball

EN > Shockproof 3 watts Bluetooth® speaker. Enjoy your playlist in all conditions, alone or with your friends, without any risk of damaging it. The 6 mm silicone protection helps protect your speaker. **Built-in microphone allows you to make phone calls directly from your speaker.**

FR > Haut-parleur Bluetooth® de 3 W résistant aux chocs. Profitez de vos listes de lecture en toutes circonstances, seul ou avec vos amis. Grâce à sa protection en silicone de 6 mm d'épaisseur, il n'y a aucun risque de l'abîmer ! **Le microphone intégré vous offre la possibilité de téléphoner directement du haut-parleur.**

ES > Altavoz Bluetooth® de 3 watts a prueba de golpes. Disfruta de tus listas de reproducción en cualquier tipo de condiciones, solo o con tus amigos, ¡sin riesgo de dañarlo. La protección de silicona de 6 mm de grosor te ayuda a protegerlo. **El micrófono incorporado te ofrece la opción de llamar por teléfono directamente desde el altavoz.**

DE > Stoßfester 3W Bluetooth®-Lautsprecher. Genießen Sie Ihre Playlists in allen Situationen, alleine oder mit Ihren Freunden, ohne das Risiko einer Beschädigung! Der 6mm-Silikonschutz schützt Ihren Lautsprecher! **Mit dem eingebauten Mikrofon können Sie direkt vom Lautsprecher aus telefonieren!**

IT > Altoparlante Bluetooth® da 3 W resistente agli urti. Goditi le tue playlist in qualsiasi situazione, da solo o con i tuoi amici, senza rischiare di rovinarlo! Il rivestimento in silicone con uno spessore di 6 mm ti aiuta a proteggerlo. **Il microfono incorporato ti offre la possibilità di fare una telefonata direttamente dall'altoparlante.**

Shockproof 3W Bluetooth® speaker ideal for outdoor activities

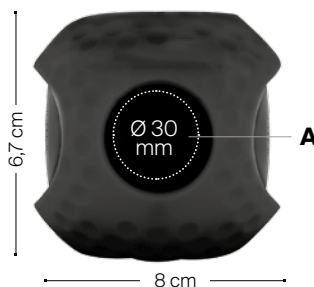

09659
A > DO: 4-colour process

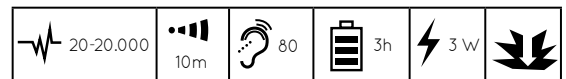

FR > Haut-parleur Bluetooth® 3 W résistant aux chocs, idéal pour des activités de plein air

ES > Altavoz Bluetooth® 3W a prueba de golpes ideal para actividades al aire libre

DE > Stoßfester 3W Bluetooth®-Lautsprecher - ideal für Aktivitäten im Freien

IT > Altoparlante Bluetooth® da 3W resistente agli urti, ideale per l'attività all'aria aperta

MOQ: 10 u. 40 ±10,6 Kg





Vintage Bluetooth® speaker

EN > Stylish 2 x 3W Bluetooth® stereo speaker that provides excellent quality sound due to the smart distribution of the basses and the treble. **2.000 mAh rechargeable battery for up to 6 hours playtime.** Built-in microphone for hands-free speaker-phone calling. Includes micro USB cable.

FR > Élégant haut-parleur de 2 x 3 W avec Bluetooth® qui offre une excellente qualité de son, grâce à la distribution ingénieuse des sons graves et aigus. **Batterie rechargeable de 2 000 mAh pour une durée d'utilisation allant jusqu'à 6 heures.** Microphone incorporé pour pouvoir utiliser le haut-parleur en mode mains libres pendant les communications. Câble micro USB inclus.

ES > Elegante altavoz 2 x 3W con Bluetooth® que proporciona una excelente calidad de sonido gracias a la distribución inteligente de los graves y los agudos. **Batería recargable de 2.000 mAh para un uso de hasta 6 horas.** Micrófono incorporado para poder usar el altavoz como manos libres en las llamadas. Incluye cable micro USB.

DE > Stylisher 2 x 3 W Bluetooth® Lautsprecher, der überragende Soundqualität bietet - dank der smarten Ausbreitung der Bässe und Höhen. **Der 2000 mAh-Akku garantiert bis zu sechs Stunden Laufzeit.** Eingebautes Mikrofon für Freisprech-Telefonate. Inklusive Mikro-USB-Kabel.

IT > Elegante altoparlante 2 x 3 W Bluetooth® con un'ottima qualità del suono grazie alla distribuzione intelligente di bassi e alti. **Batteria ricaricabile da 2.000 mAh che garantisce fino a 6 ore di autonomia.** Microfono incorporato per chiamate in viva voce. Include cavo micro USB.

Powerful sound in a retro metal casing!

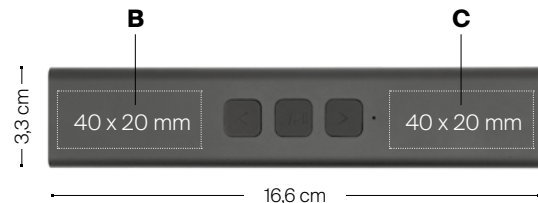
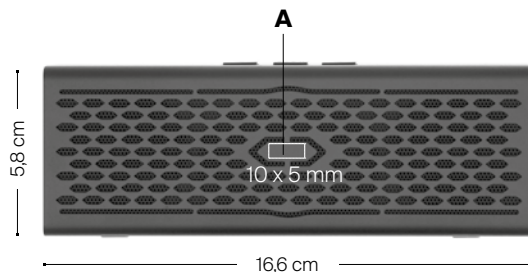

09658

A > L: plate
B > L: top left
C > L: top right

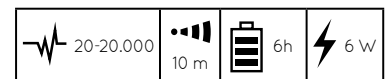

FR > Son puissant avec un boîtier métallique rétro!

ES > ¡Sonido potente en una carcasa metálica retro!

DE > Kraftvoller Sound in einem Retro-Metallgehäuse

IT > Suono potente in una struttura metallica vintage!

MOQ: 10 u. 30 ± 8,9kg



Rainbow mouse



EN > This 1000 dpi colorful mouse features 2 silent click buttons and a clickable scroll. **Enjoy a fun two colors design and USB cable matching the mouse body color.**

FR > Cette souris colorée, 1000 dpi, est dotée de 2 boutons et scroll cliquable. **Profitez d'un design fun et bicolore et un câble USB de la même couleur que le corps de la souris.**

ES > Este ratón colorido de 1000 ppp cuenta con 2 botones clic silenciosos y un scroll en el que se puede hacer clic. **Disfruta de un divertido diseño de dos colores y un cable USB que combina con el color del cuerpo del ratón.**

DE > Farbenfrohe 1000 dpi-Maus mit zwei leisen Schaltflächen und klickbarem Scrollrad. **Genießen Sie das frische zweifarbige Design mit farblich passendem USB-Kabel.**

IT > Il colorato mouse da 1000 dpi ha 2 pulsanti silenziosi e uno scroll su cui è possibile cliccare. **Ha un divertente design bicolore e un cavo USB della stessa tonalità del corpo del mouse.**

Fun and coloured wired mouse



09699
A > BP: box front, full-colour

	1,000 dpi
--	-----------



FR > Souris fun et coloré avec cable

ES > Divertido y colorido ratón con cable

DE > Farbenfrohe kabelgebundene Maus

IT > Mouse con cavo divertente e colorato

MOQ: 10 u. 100 ±10 Kg



Lumy Wired mouse

EN > Wired 1000 DPI optical mouse with the relaxing effect of light with changing backlit colour: LED with 7 automatic colours. Two buttons and click wheel. **Compatible with PC/MAC®.USB connectivity.**

FR > Souris optique avec câble de 1000 DPI et effet relaxant câble à la lumière LED changeante avec 7 couleurs en alternance. Deux boutons et une molette avec clic. **Compatible avec PC/MAC®. Connexion USB.**

ES > Ratón óptico con cable de 1000 dpi y con un efecto relajante de luz LED cambiante que alterna 7 colores. Dos botones y rueda con click. **Compatible con PC/MAC®. Conexión USB.**

DE > 1000 dpi optische, kabelgebundene Maus mit entspannendem Hintergrund-Lichteffekt: LEDs mit 7 automatisch wechselnden Farben. Zwei Tasten und ein Klickrad. **Kompatibel für PC/MAC®. USB-Schnittstelle.**

IT > Mouse ottico con cavo da 1000 dpi, con un rilassante effetto di luce LED che cambia alternando 7 colori. Due pulsanti e rotellina con click. **Compatible con PC/MAC®. Collegamento USB.**



Enjoy the relaxing effect of the changing colour LED backlight

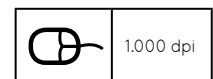
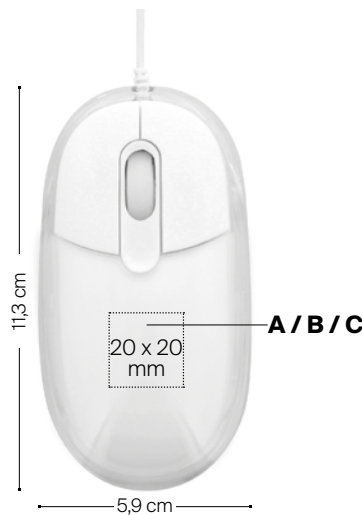

09666

- A > BP: front, full-colour
- B > BPT: front, full-colour
- C > PD: front, max. 1 colour



FR > Profitez de l'effet relaxant du rétro-éclairage LED à couleur changeante

ES > Disfruta el relajante efecto de luz LED cambiante retroiluminada

DE > Genießen Sie den entspannenden Effekt der wechselnden LED-Hintergrundbeleuchtung

IT > Goditi il rilassante effetto del LED cangiante retroilluminato

MOQ: 10 u.



Mini Wireless mouse

EN > Compact size wireless optical mouse ideal for travelling. **Specific compartment below the mouse to store the wireless receiver and never lose it.** Automatic sleeping mode for more extended use. Silent click for maximum comfort.

FR > Souris sans fil de taille compacte, idéale pour voyager. **Compartment spécifique situé sous la souris pour loger le récepteur et ne pas l'égarer.** Mode de mise en attente automatique pour une utilisation prolongée. Confort maximal grâce à son clic silencieux.

ES > Ratón inalámbrico de tamaño compacto ideal para viajar. **Compartimento específico debajo del ratón para albergar el receptor y no perderlo nunca.** Modo de espera automático para ampliar el uso. Click silencioso para un máximo confort.

DE > Kabellose optische Maus in kompakter Größe - ideal auf Reisen. **Extrafach an der Unterseite, um den kabellosen Receiver zu verstauen und niemals zu verlieren.** Automatischer Sleep-Modus als zusätzliche Nutzungsmöglichkeit. Leiser Klickton für maximalen Komfort.

IT > Mouse senza fili di dimensioni compatte ideale per viaggiare. **Un apposito scomparto sotto il mouse consente di riporre il ricevitore, evitando di perderlo.** Modalità sleep automatica per un uso prolungato. Click silenzioso per un comfort ottimale.

Compact size and wireless, ideal for travelling

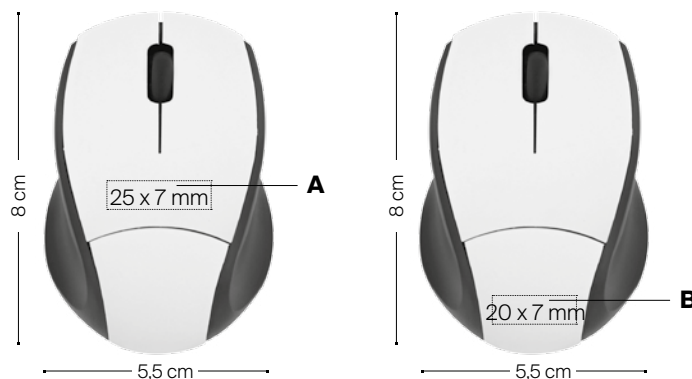

09668

A > PD: front center, max. 1 colour
B > PD: front lower, max. 1 colour

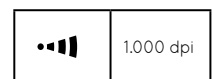

FR > Compact et sans câble, idéal pour voyager

ES > Compacto y sin cables, ideal para viajar

DE > Kompakte Größe und kabellos - ideal auf Reisen

IT > Compatto e senza fili, ideale per viaggiare



MOQ: 10 u. 100
± 5,4 Kg

Ultra-thin laptop case

EN > Patented case designed in France that provides optimal protection for ultra-thin laptops up to 13.3". Slim profile with adjustable elastic system to provide the correct fit. **Smart tab at the bottom to ensure air flow to the laptop and also for use as a stand.** Compatible with Ultrabook™, MacBook® Air, Asus® ZenBook and many more.

FR > Étui breveté et conçu en France pour offrir une protection optimale aux portables ultra-fins jusqu'à 13,3". Profil fin avec système élastique réglable pour un ajustement optimal. **Rabat sur la partie inférieure pour garantir la circulation d'air du portable et pour utiliser l'étui comme support.** Compatible avec Ultrabook™, MacBook® Air, Asus® ZenBook et bien d'autres.

ES > Funda patentada diseñada en Francia que proporciona una protección óptima para portátiles ultrafinos de hasta 13,3". Perfil fino con sistema elástico ajustable para proporcionar el ajuste adecuado. **Creativa solapa en la parte inferior para garantizar la circulación de aire al portátil y también para usar la funda como soporte.** Compatible con Ultrabook™, MacBook® Air, Asus® ZenBook y muchos más.

DE > In Frankreich designte, patentierte Hülle, die ultradünnen Laptops bis zu 13,3" optimalen Schutz bietet. Schlankes Profil mit verstellbarem Elastikbandsystem für sicheren Halt. **Kleine Klappe an der Rückseite, die die Belüftung des Laptops gewährleistet und auch zum Aufstellen geeignet ist.** Kompatibel für Ultrabook™, MacBook® Air, Asus® ZenBook, und viele andere.

IT > Custodia brevettata di design francese, offre una protezione ottimale per notebook ultrasottili fino a 13,3 pollici. Profilo sottile, con sistema elastico regolabile per ottenere la misura appropriata. **Una pratica aletta nella parte inferiore assicura la circolazione dell'aria al notebook e permette di usare la custodia anche come supporto.** Compatibile con Ultrabook™, MacBook® Air, Asus® ZenBook e molti altri.



Patented design from France to provide optimal protection for your laptop!

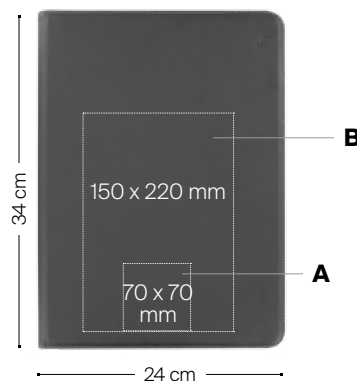

09679

A > DB: cover lower, max. 1 colour

B > SP: cover, max. 1 colour



FR > Design français breveté pour offrir une protection optimale à votre portable!

ES > ¡Diseño francés patentado para ofrecer una protección óptima a tu portátil!

DE > Patentiertes Design aus Frankreich für optimalen Schutz Ihres Laptops!

IT > Design francese brevettato per proteggere in modo ottimale il tuo notebook!

MOQ: 10 u.



± 2,6 Kg



Stone power bank 4000 mAh & 6600 mAh

EN > Compact power bank in the shape of a stone. **Battery level is indicated with 4 lights.** Includes micro USB cable.

FR > Batterie externe compacte en forme de pierre. **Le niveau de charge est indiqué au moyen de 4 lumières.** Câble micro USB inclus.

ES > Batería externa compacta con forma de piedra. **El nivel de carga se indica con 4 luces.** Incluye cable micro USB.

DE > Kompakte Power-Bank in Form eines Steines. **Der Batteriestand wird mit 4 Leuchten angezeigt.** Inklusive Mikro-USB-Kabel.

IT > Batteria esterna compatta a forma di pietra. **Il livello di carica viene indicato con 4 luci.** Include cavo micro USB.



09664



09665

75%

09664

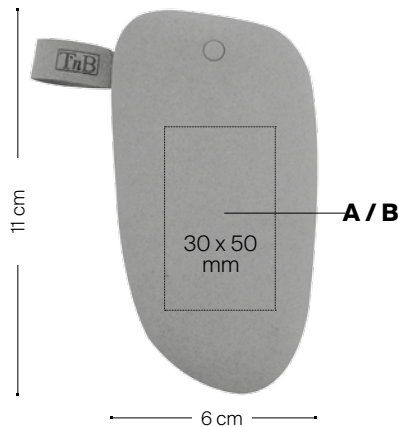

09665

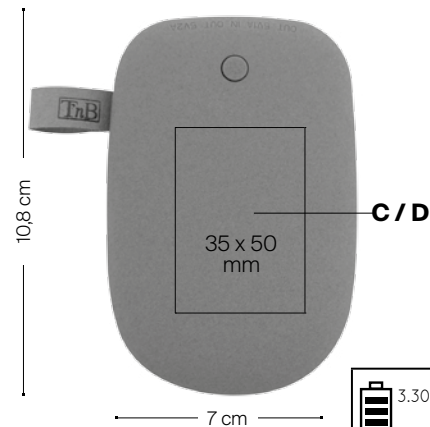

09664 / 09665
A / C > BP: front, full-colour
B / D > BPT: front, full-colour



PHONE ACCESSORIES

TnB®



FR > Comme le toucher d'une vraie pierre!

ES > ¡Como una piedra real al tacto!

DE > Fühlt sich an wie ein echter Stein!

IT > Sembra una vera pietra, anche al tatto!



MOQ: 10 u. ±8,6 Kg

Ultra-slim power bank 4000 mAh NEW

EN > Ultra-slim power bank 4000 mAh with built in micro USB cable. This compact and slim power bank is easy to slip into your suitcase or your bag thanks to its 8 mm thinness.

You can triple the autonomy of your smartphone depending on the model.

Integrated micro USB cable so that you can recharge it wherever you are. Velvet pouch included.

FR > Batterie externe ultra plate 4000 mAh avec câble micro USB intégré. Cette batterie externe ultra plate et compacte se glissera facilement dans votre sac ou dans votre valise grâce à ses 8 mm d'épaisseur.

Vous pouvez tripler l'autonomie de votre smartphone en fonction du modèle. De plus, grâce à son câble micro USB intégré, rechargez-la en un geste, où que vous soyez.

ES > Power bank ultra plano de 4000 mAh con cable micro USB integrado. Este power bank compacto cabe fácilmente en cualquier bolsa o maleta gracias a sus sólo 8 mm de grosor. **Puedes llegar a triplicar la autonomía de tu smartphone dependiendo del modelo.** Gracias a su cable micro USB integrado puedes recargarlo en cualquier parte.

DE > Ultradünne Power-Bank 4.000 mAh mit eingebautem Mikro-USB-Kabel. Diese kompakte Power-Bank lässt sich dank ihrer schlanken 8mm-Dicke ganz leicht in Ihrem Koffer oder in Ihrer Tasche verstauen. **Sie können die Leistung Ihres Smartphones, je nach Modell, verdreifachen.** Darüber hinaus können Sie sie dank des integrierten Mikro-USB-Kabels überall wieder aufladen, wo auch immer Sie unterwegs sind.

IT > Caricatore portatile ultrasottile da 4000 mAh con cavo micro USB integrato. Puoi comodamente infilare questo caricatore portatile sottile e compatto nella tua valigia o nella tua borsa, grazie al suo spessore di soli 8 mm. **Puoi arrivare a triplicare l'autonomia del tuo smartphone, a seconda del modello.** Inoltre, grazie al suo cavo micro USB integrato, puoi ricaricarlo ovunque tu sia.

Integrated micro USB cable so that you can recharge it wherever you are

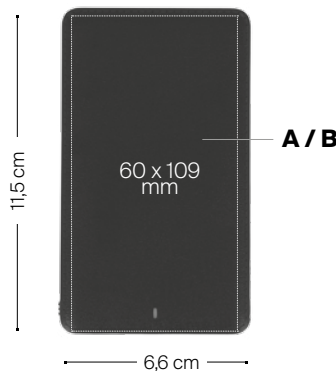

09702

A > BP: front, full-colour

B > BPT: front, full-colour



FR > Grâce à son câble micro USB intégré, rechargez-la en un geste.

ES > Gracias a su cable micro USB integrado puedes recargarlo en cualquier parte.

DE > Dank des integrierten Mikro-USB-Kabels können Sie überall wieder aufladen, wo auch immer Sie unterwegs sind.

IT > Grazie al suo cavo micro USB integrato, puoi ricaricarlo ovunque tu sia.



MOQ: 10 u. 40
± 6,6 Kg

Ultra-slim power bank 4000 MFi & Slim power bank 6000 mAh

NEW

NEW

EN > Ultra-slim power bank with built in micro USB cable and lightning adapter. **This compact and slim power bank is easy to slip into your suitcase or your bag.** You can triple the autonomy of your smartphone depending on the model. If you have an iPhone® (iPhone 5® or other), use the lightning adapter provided and plug it into the micro USB port. Moreover, thanks to its integrated micro USB cable, recharge it wherever you are. Black velvet pouch included.

FR > Batterie externe ultra plate avec câble micro USB intégré et adaptateur Lightning. **Cette batterie externe ultra plate et compacte se glissera facilement dans votre sac ou dans votre valise.** Vous pouvez tripler l'autonomie de votre smartphone en fonction du modèle. Si vous possédez un iPhone® (iPhone 5® ou autre), utilisez l'adaptateur Lightning fourni et branchez-le sur le port micro USB. De plus, grâce à son câble micro USB intégré, rechargez-la en un geste, où que vous soyez.

ES > Power bank ultra plano con cable micro USB y adaptador Lightning integrados. **Este power bank compacto cabe fácilmente en cualquier bolsa o maleta.** Puedes llegar a triplicar la autonomía de tu smartphone dependiendo del modelo. En caso de iPhone® (iPhone 5® o similar), utiliza el adaptador Lightning integrado y conéctalo al puerto micro USB. Además, gracias a su cable micro USB integrado puedes recargarlo en cualquier parte.

DE > Ultradünne Power-Bank mit eingebautem Mikro-USB-Kabel und Lightning-Adapter. **Kompakt und leicht wie sie ist, lässt sie sich einfach in Ihrem Koffer oder Ihrer Tasche verstauen.** Sie können die Leistung Ihres Smartphones, je nach Modell, verdreifachen. Wenn Sie ein iPhone® (iPhone 5® oder nachfolgendes) nutzen, verbinden Sie einfach den beige-fügten Lightning-Adapter mit Ihrem Micro-USB-Port. Darüber hinaus können Sie sie dank des integrierten Mikro-USB-Kabels überall wieder aufladen, wo auch immer Sie unterwegs sind.

IT > Caricatore portatile ultrasottile con cavo micro USB integrato e adattatore Lightning. **Puoi comodamente infilare questo caricatore portatile sottile e compatto nella tua valigia o nella tua borsa.** Puoi arrivare a triplicare l'autonomia del tuo smartphone, a seconda del modello. Se hai un iPhone® (iPhone 5® o simili), utilizza l'adattatore Lightning in dotazione e inseriscilo nella porta micro USB. Inoltre, grazie al suo cavo micro USB integrato, puoi ricaricarlo ovunque tu sia.



09701 / 09703
A / C > BP: front,
full-colour
B / D > BPT: front,
full-colour

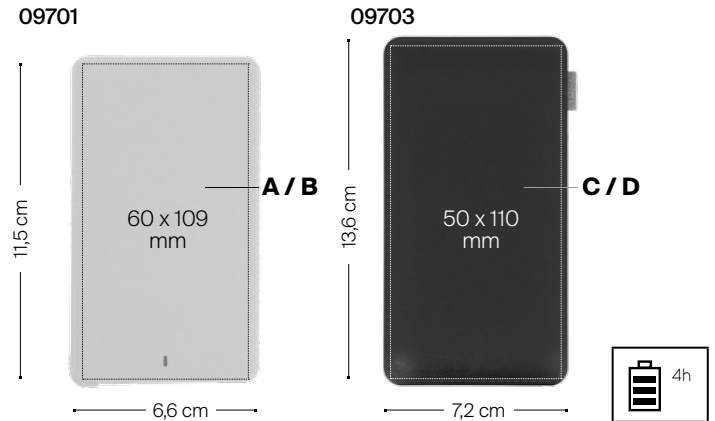

MOQ: 10 u.

09701	09703
40	40
±6.6 Kg	±9.2 Kg



HD Action Camera



EN > Take videos and pictures of your adventures with this quality 720p action camera. Micro HDMI and micro USB connections. Maximum capacity of 32 GB (using a micro-SD card, not included). **Water-resistant up to 60 meters, user manual and 7 different holding accessories.**

FR > Prenez des vidéos et des photographies de vos aventures avec cette caméra d'action 720p. Connexions micro HDMI et micro USB. Capacité maximale de 32 Go (avec une carte micro-SD, non incluse). **Livrée avec boîtier résistant à l'eau jusqu'à 60 mètres, câble micro USB, manuel de l'utilisateur et 7 accessoires de maintien différents.**

ES > Graba vídeos y saca fotos de tus aventuras con esta cámara de acción de 720p. Conexiones micro HDMI y micro USB. La capacidad máxima es de 32 GB (usando una tarjeta micro SD -no incluida-). **Incluye carcasa sumergible hasta 60 metros, cable micro USB, manual de instrucciones y 7 accesorios de sujeción distintos.**

DE > Halten Sie Ihre Abenteuer in Videos und Fotos mit dieser qualitativ hochwertigen 720p Action-Kamera fest. Mikro-HDMI und Mikro-USB-Verbindungen. Maximale Speicherkapazität von 32 GB (mit Mikro-SD-Karte - nicht enthalten). **Mit bis zu 60 m wasserresistenter Tasche, Mikro-USB-Kabel, Bedienungsanleitung und 7 verschiedenen Zubehöerteilen.**

IT > Gira filmati e scatta foto delle tue avventure con questa action camera ad alta definizione 720p. Connessioni micro HDMI e micro USB. Capacità massima di memoria di 32 GB (con una card micro-SD, non inclusa). **Dotata di involucro impermeabile fino a 60 metri di profondità, cavo micro USB, manuale di istruzioni e 7 diversi accessori di supporto.**

Water-resistant,
90 minutes
of battery
autonomy.

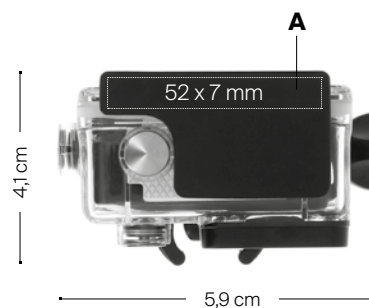

09686
A > BP: full-colour

720p 30fps	3MP	120°	1.5"
---------------	-----	------	------



FR > Résistant à l'eau, 90 minutes d'autonomie de la batterie.

ES > Resistente al agua, 90 minutos de autonomía de la batería.

DE > Wasserabweisend, 90 Minuten Batterieleistung.

IT > Water-resistant, con 90 minuti di autonomia

MOQ: 10 u.

2

± 0,9 Kg



4K Action Camera

EN > Real 4K video resolution, 16 megapixel CMOS. **This action camera will make your adventures just as exciting on screen as in real life.** WiFi, micro HDMI and micro USB connections. Built-in microphone. Maximum capacity of 32 GB (using a micro-SD card, not included). Water-resistant up to 60 meters, user manual and 12 different holding accessories.

FR > Caméra, résolution 4K et capteur CMOS 16 megapixel. **Cette caméra d'action rendra vos aventures aussi excitantes à l'écran que dans la vie réelle.** Wifi, connexions pour micro HDMI et micro USB. Capacité maximum de la SD-card de 32 GB (utilisez une micro-SD non incluse). Waterproof jusqu'à 60 mètres, manuel d'utilisation et 12 accessoires différents de fixation.

ES > Resolución de vídeo 4K real, sensor CMOS de 16 megapíxeles. **Esta cámara de acción hará que tus aventuras sean tan emocionantes en pantalla como en la vida real.** WiFi y conexiones micro HDMI y micro USB. Micrófono integrado. La capacidad máxima es de 32 GB (usando una tarjeta micro SD no incluida). Resistente al agua hasta 60 metros, manual de instrucciones y 12 accesorios de sujeción distintos.

DE > Reale 4K Video-Auflösung, 16 Megapixel CMOS und 170° Weitwinkelobjektiv. **Diese Action-Camera wird Ihre Abenteuer auf dem Bildschirm ebenso spannend wiedergeben wie sie im echten Leben passiert sind!** 2 Zoll TFT-LCD-Bildschirm an der Rückseite, so dass Sie Ihre Videos sofort anschauen können. Genießen Sie bis zu 90 Minuten Akkulaufzeit des herausnehmbaren Lithium-Ionen-Akkus. WiFi, Mikro-HDMI und Mikro-USB-Anschluss. Integriertes Mikrofon. Maximale Speicherkapazität von 32 GB (mit Mikro-SD-Karte – nicht enthalten). Mit bis zu 60 m wasserresistenter Tasche, Mikro-USB-Kabel, Bedienungsanleitung und 12 verschiedenen Zubehörteilen..

IT > Risoluzione video reale 4K, 16 megapixel CMOS. **Questa action camera renderà le tue avventure nello schermo eccitanti quanto nella vita reale.** WiFi, connessioni micro HDMI e micro USB. Microfono incorporato. Massima capacità di 32 GB (usando una micro-SD non inclusa). Water resistant fino a 60 metri, manuale d'istruzione e 12 differenti accessori inclusi.

Make your movies as exciting as your stunts thanks to the 4K quality!

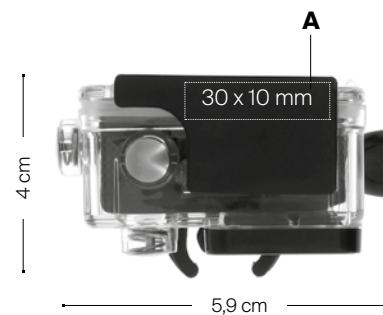

09685
A > BP: full-colour

720p 30fps	16MP	120°	1,5"
---------------	------	------	------



FR > Faites des vidéos aussi excitantes que vos aventures grâce à la qualité 4K!

ES > ¡Haz videos tan emocionantes como tus aventuras gracias a la calidad 4K!

DE > Gestalten Sie mit der 4K-Qualität aufregende Videos, Stunts etc.!

IT > Potrai rivivere le emozioni delle tue avventure grazie alla qualità 4K dei filmati!

MOQ: 10 u. 2
±1.2 Kg



Patent Protection
Make: World Adapter MUV USB T-2.5AH 250V
Use only with Fuse 1P20T1A40 2.5AH 250V
Trace use only / 50160 Hz, 50160 Hz, 2.5A 625W
N
Trace in Thailand 100-250V, 50160 Hz, 50160 Hz, 2.5A 625W
Output: 100-250V, 50160 Hz, 2.5A 625W
Output: 100-250V, 50160 Hz, 2.5A 625W
Intermitted time: 1h 15m
USB Charger 50160Hz, 2.5A 625W
Input: 100-250V, 50160 Hz, 2.5A 625W
max. 20W, max. 200mA
Output: 5V DC, max. 2.1A



SKROSS[®]
Convert voltage
Adapter does not
plug when not in use
CAUTION
Unplug adapter and
adapter when not in use



Midget Dual USB Car Charger

EN > No matter where you are travelling, the Midget Dual USB Car Charger from SKROSS® makes it easy for long-distance travellers to ensure their batteries are always fully charged on the road – simultaneously for two devices – simply and without wasting space. **Suitable for car, camper and boat.**

FR > Peu importe où vous partez en voyage ! Sur des trajets de longue distance, le chargeur pour voiture SKROSS® Midget Dual USB vous permet de charger la batterie de vos appareils directement dans la voiture (deux appareils en simultanée). Il est facile à utiliser et il ne prend pas de place. **Adapté pour voitures, camping-car et bateaux.**

ES > No importa a dónde vayas, el cargador para el coche Midget dual USB de SKROSS® facilita que quienes recorren largas distancias por carretera puedan cargar la batería de sus dispositivos en marcha (simultáneamente en dos dispositivos) de manera fácil y sin ocupar espacio. **Apto para turismo, autocaravanas y barcos.**

DE > Wo auch immer Sie reisen: das Midget Dual USB-Autoladegerät von SKROSS® macht es Reisenden auf weiten Strecken einfach, ihre Akkus auch unterwegs immer voll geladen zur Verfügung zu haben - parallel für zwei Geräte - einfach und platzsparend. **Geeignet für Autos, Camper und Boote.**

IT > Qualunque sia la tua destinazione, il caricatore per auto SKROSS® Midget dual USB assicura batterie sempre cariche anche durante lunghi viaggi. Permette di caricare contemporaneamente due dispositivi in modo semplice e senza sprecare spazio. **Adatto per turismo, autocarovane e barche.**

Dual charging on the go!



*09009

A > PD: front, max. 2 colours



FR > Double charge en marchant

ES > Doble carga en marcha

DE > Doppeltes Aufladen unterwegs

IT > Doppia carica in mobilità

*While stock lasts

MOQ: 10 u.  50
± 1,6 Kg

Euro USB Charger

EN > The Euro USB Charger from SKROSS® ensures full batteries on all USB devices. **The dual USB port in connection with the exceptional performance capability of 2400 mA enables two USB devices to be charged simultaneously.**

FR > Le chargeur USB européen de SKROSS® assure la recharge totale des batteries de tous les appareils USB. **Le double port USB, combiné avec la capacité exceptionnelle de 2400 mA, permet de charger simultanément deux appareils USB.**

ES > El cargador Euro USB de SKROSS® asegura que las baterías estén totalmente cargadas en todos los dispositivos USB. **El puerto doble USB en conexión junto con la excepcional capacidad de 2400 mA permite que dos dispositivos USB se carguen simultáneamente.**

DE > Das Euro USB-Ladegerät von SKROSS® gewährleistet volle Akkus für alle USB-Geräte. **Der duale USB-Port in Verbindung mit außergewöhnlicher Leistung von 2400 mA ermöglicht paralleles Laden zweier USB-Geräte.**

IT > Il caricatore Euro USB di SKROSS® assicura batterie cariche in tutti i dispositivi USB. **La doppia porta USB, assieme all'eccezionale capacità di performance di 2400 mA, permette di caricare contemporaneamente due dispositivi USB.**

Safety and Swiss design all in one!

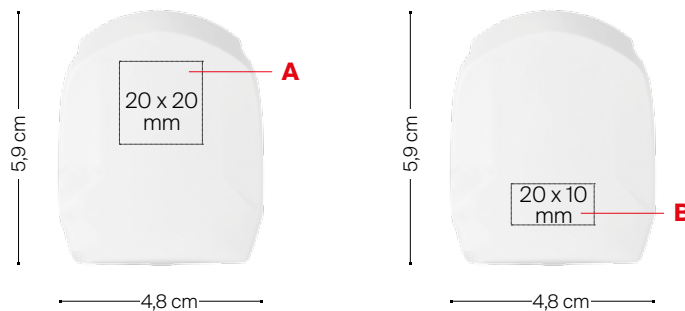

*09523

A> PD: front upper, max. 2 colours
B> PD: front lower, max. 2 colours



FR > Sécurité et design suisse réunis dans un seul appareil!

ES > ¡Seguridad y diseño suizo, todo en uno!

DE > Sicherheit und Schweizer Design in einem!

IT > Sicurezza e design svizzero tutto in uno!

*While stock lasts

MOQ: 10 u.

50
±3,9 Kg

World to Europe USB

- EN >** An easy, reliable connection to the European standard plug for devices from all over the world, with built-in USB charger that can be used at the same time. **Suitable for equipment with earthed and unearthed plugs (2 and 3 poles) and USB devices.** Receptacles for: Switzerland, Italy, Australia/China, UK, USA/Japan and Brazil.
- FR >** Connexion facile et fiable à la prise standard européenne pour les dispositifs du monde entier, avec chargeur USB incorporé pouvant être utilisé simultanément. **Convient pour des équipements avec des prises raccordées ou non à la terre (à 2 et 3 pôles) et des dispositifs USB.** Entrées pour : Suisse, Italie, Australie/Chine, Royaume-Uni, USA/Japon et Brésil.
- ES >** Conexión fácil y fiable al enchufe estándar europeo para dispositivos de todo el mundo, con cargador USB integrado que se puede usar al mismo tiempo. **Apto para equipamiento con enchufes con y sin toma de tierra (de 2 y 3 polos) y dispositivos USB.** Entradas para Suiza, Italia, Australia/China, Reino Unido, EEUU/Japón y Brasil.
- DE >** Zuverlässige und einfache Verbindung für Geräte aus der ganzen Welt mit dem europäischen Normstecker, inkl. integriertem USB-Ladegerät für zeitgleiche Verwendung. **Geeignet für geerdete und ungeerdete Stecker (2- und 3-polig) sowie USB-Geräte.** Steckdoseneingang für: Schweiz, Italien, Australien/China, UK, USA/Japan und Brasilien.
- IT >** Collegarsi alle prese standard europee con dispositivi internazionali è semplice e affidabile; con caricabatterie USB integrato, che puoi usare contemporaneamente. **Adatto per apparecchiature dotate di spine con e senza messa a terra (a 2 e 3 poli) e dispositivi USB.** Spine per Svizzera, Italia, Australia/Cina, Regno Unito, USA/Giappone e Brasile.

The whole world at home in Europe!

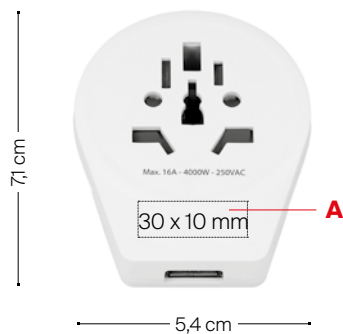

09677
A > PD: max. 2 colours



FR > Le monde entier chez soi, en Europe!

ES > ¡El mundo entero en casa, en Europa!

DE > Die ganze Welt in Europa zu Hause!

IT > Tutto il mondo a casa, in Europa!



MOQ: 10 u. 50 ± 3 Kg

Pro Light USB

EN > Ultra compact 3-pole travel adapter that can be used in over 100 countries and functions as both a travel plug and USB charger for travellers from Europe. **Suitable for connecting powerful devices such as laptops or travel hairdryers and charging two smartphones via USB at the same time.**

FR > Adaptateur de voyage à 3 pôles ultra-compact pouvant être utilisé dans plus de 100 pays et servant aussi bien de prise de voyage que de chargeur USB pour les voyageurs européens. **Convient pour connecter des dispositifs puissants tels que portables ou sèche-cheveux de voyage, et pour charger deux smartphones en même temps via USB.**

ES > Adaptador de viaje de 3 polos ultracompacto que puede usarse en más de 100 países y que funciona tanto como enchufe de viaje, como cargador USB para viajeros europeos. **Apto para conectar dispositivos potentes como portátiles o secadores de pelo de viaje y cargar via USB dos smartphones al mismo tiempo.**

DE > Ultra kompakter 3-poliger Reiseadapter für über 100 Länder, der sowohl als Reisestecker, als auch als USB-Ladegerät für Reisende aus Europa dient. **Geeignet, um ein leistungsstarkes Gerät wie Laptop oder Reisehaartrockner anzuschließen und gleichzeitig zwei Smartphones über USB zu laden.**

IT > Adattatore da viaggio a 3 poli ultracompatto, utilizzabile in più di 100 paesi, funziona sia come spina da viaggio, sia come caricabatterie USB per i viaggiatori europei. **Adatto per collegare alla corrente dispositivi potenti come notebook o asciugacapelli viaggio e, allo stesso tempo, ricaricare tramite USB due smartphone.**



The smallest 3-pole world travel adapter with built-in USB charger!



100%

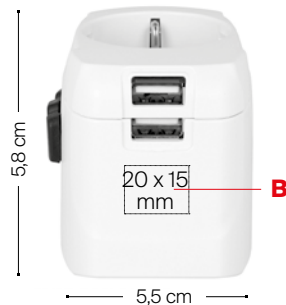
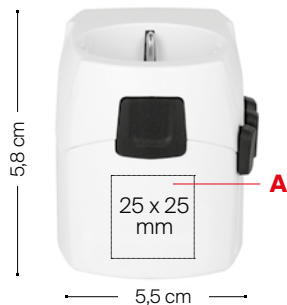

09678

A > PD: max. 2 colours

B > PD: max. 2 colours

C > PD: max. 2 colours



FR > Le plus petit des adaptateurs de voyage à 3 pôles, et avec chargeur USB intégré !

ES > El adaptador de viaje de 3 polos más pequeño ¡con cargador USB integrado!

DE > Der kleinste 3-polige Welt-Reiseadapter mit integriertem USB-Ladegerät!

IT > Il più piccolo adattatore da viaggio a 3 poli, con caricabatterie USB integrato!

MOQ: 10 u.

50
± 72 Kg

World Adapter MUV USB

EN > This innovative 2-pole adapter can be used in over 220 countries and functions as both as travel plug and USB charger. It can connect simultaneously one unearthed 2-pole-plug and two USB devices with a rich charging output of 2400 mA shared.

FR > Cet adaptateur innovant à 2 pôles peut être utilisé dans plus de 220 pays et sert à la fois d'adaptateur de voyage et de chargeur USB. Grâce à la grande capacité de charge de sa batterie (2400 mA), vous pouvez brancher en même temps un appareil équipé d'une prise à 2 pôles et deux appareils USB.

ES > Este innovador adaptador de 2 polos puede usarse en más de 220 países y funciona como enchufe de viaje y como cargador USB a la vez. Puede conectar simultáneamente un enchufe de 2 polos sin toma de tierra y dos dispositivos USB gracias a su alta capacidad de carga de 2400 mA.

DE > Dieser innovative 2-polige Adapter kann in über 220 Ländern als Reisestecker und USB-Ladegerät eingesetzt werden. Er stellt 2400 mA Ladepower bereit und kann damit zeitgleich zwei USB-Geräte aufladen, und einen ungeerdeten 2-poligen Stecker verbinden.

IT > Questo innovativo adattatore a due poli può essere usato in più di 220 paesi e funziona come caricatore da viaggio e caricatore USB contemporaneamente. Con una carica di 2400 mA permette di collegare simultaneamente una spina a 2 poli e due dispositivi USB.

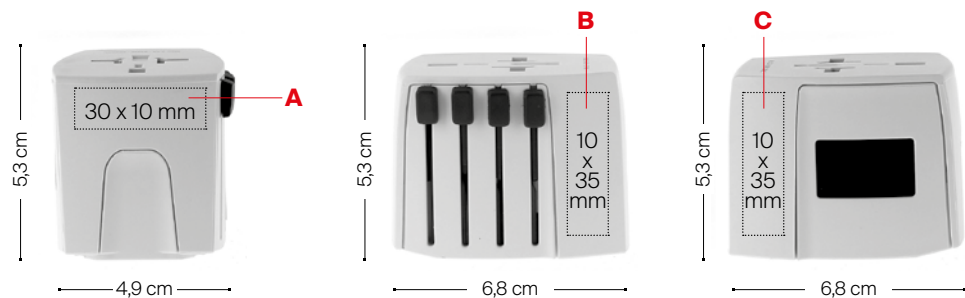
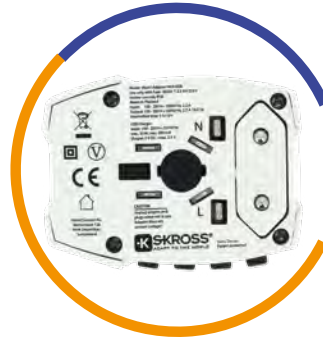

09474

A > PD: max. 2 colours

B > PD: max. 2 colours

C > PD: max. 2 colours



MOQ: 10 u.

50
±11,8 Kg

LIGHTERS SPECIAL PACKAGING

- 280** Count Box for 10 units
- 281** Standard Packaging for BIC®
Lighters: Tray of 50 units
- 281** Standard Packaging for BIC®
Lighters Cases: Box of 50 units

WRITING INSTRUMENTS SPECIAL PACKAGING

- 278** BIC® Cotton drawstring pouch
- 277** Black Two-Piece Gift Box
- 276** Black Velvet Pouch
- 276** Carton Black & Silver colour gift box
- 274** Cello Wrap
- 275** Frosted Pouch
- 279** Hinged Gift Box
- 275** Media Pack
- 279** See-Through Gift Box



PACKAGING



Cello Wrap

- 20001: 1 product
- 20002: 2 products
- 20003: 3 products
- 20004: 4 products

- EN >** Not available for graphite pencils or metal pens.
Due to different printing processes, the imprint colours on pens and notepads may slightly differ.
- FR >** Non disponible pour crayons et Stylos métallisés.
Du fait des différents procédés d'impression utilisés, les couleurs de marquage peuvent différer légèrement.
- ES >** No disponible para lápices ni bolígrafos metálicos.
Debido al uso de diferentes procesos de impresión, los colores de los bolígrafos y los blocks de notas pueden variar ligeramente.
- DE >** Nicht erhältlich für Bleistifte oder Metallkugelschreiber.
Aufgrund unterschiedlicher Drucktechniken können die Druckfarben auf den Schreibgeräten und auf den Haftnotizen leicht voneinander abweichen.
- IT >** Non disponibile per matite né per penne metalliche.
A causa delle differenti tecniche di stampa lo stesso colore stampato su penna e blocchetto potrebbe risultare leggermente diverso.



00051
Frosted Pouch for 1 or 2 items



00049
Media Pack*

EN > Available for 1 or 2 (slim) BIC® writing instruments except: graphite pencils, BIC® Matic® Grip.

FR > Disponible pour 1 ou 2 articles (fins) d'écriture BIC®, à l'exception des crayons à papier, BIC® Matic® Grip.

ES > Disponible para 1 ó 2 instrumentos de escritura BIC® (finos) excepto lápices, BIC® Matic® Grip.

DE > Erhältlich für eines oder zwei schlanke BIC® Schreibgeräte mit Ausnahme von Graphit-Bleistiften, BIC® Matic® Grip.

IT > Disponibile per 1 o 2 strumenti da scrittura sottili BIC® eccetto matite, BIC® Matic® Grip.

EN > Developed for 3 BIC® Media Clic. Available for all BIC® writing instruments except graphite pencils.
*While stock lasts

FR > Développé pour 3 BIC® Media Clic. Disponible pour tous les articles d'écriture BIC® sauf les crayons à papier.
*Jusqu'à épuisement des stocks

ES > Desarrollado para 3 BIC® Media Clic. Disponible para todos los instrumentos de escritura BIC® excepto lápices.
*Hasta fin de existencias

DE > Für drei BIC® Media Clic geeignet. Erhältlich für alle BIC® Schreibgeräte mit Ausnahme von Graphit-Bleistiften.
*Solange der Vorrat reicht

IT > Appositamente studiato per 3 BIC® Media Clic. Disponibile per tutti i tipi di penna BIC® eccetto matite.
*Fino ad esaurimento stock



00039
Black Velvet Pouch for 1 item

00050
Black Velvet Pouch for 2 items

00062
Carton Black & Silver colour gift box*

- EN >** Available for all writing instruments, except graphite pencils.
*While stock lasts
- FR >** Disponible pour tous les articles d'écriture, à l'exception des crayons à papier.
*Jusqu'à épuisement des stocks
- ES >** Disponible para todos los productos de escritura excepto lápices.
*Hasta fin de existencias
- DE >** Erhältlich für alle Schreibgeräte außer Bleistifte.
*Solange der Vorrat reicht
- IT >** Disponibile per tutti gli strumenti da scrittura eccetto matite.
*Fino ad esaurimento stock

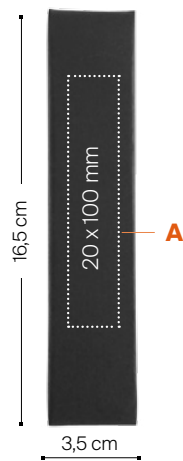

A > SP: max. 1 colour

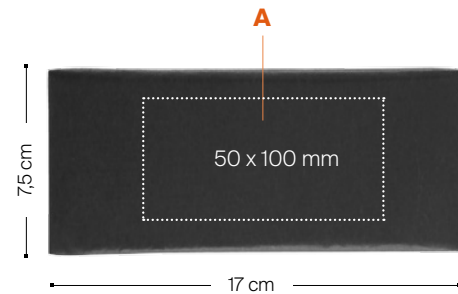

A > SP: max. 1 colour

00063
Black Two-Piece Gift Box for 1 item

00064
Black Two-Piece Gift Box for 2 items

- EN** > Available for all writing instruments, except graphite pencils.
- FR** > Disponible pour tous les articles d'écriture sauf les crayons à papier.
- ES** > Disponible para todos los productos de escritura excepto lápices.
- DE** > Erhältlich für alle Schreibgeräte außer Bleistifte.
- IT** > Disponibile per tutti gli strumenti da scrittura eccetto matite.



45%

00068
BIC® Cotton drawstring pouch

A> SP: max 2 colours
B> OT: full-colour

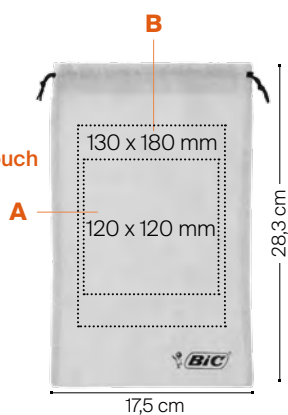

- EN > * Available for all writing instruments, except graphite pencils.
- FR > * Disponible pour tous les articles d'écriture, à l'exception des crayons à papier.
- ES > * Disponible para todos los productos de escritura excepto lápices.
- DE > * Erhältlich für alle Schreibgeräte außer Bleistifte.
- IT > * Disponibile per tutti gli strumenti da scrittura eccetto matite.



A > SP: max. 1 colour
B > BP: full colour

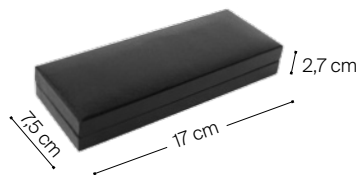

* 00065
 Hinged Gift Box for 1 or 2 items

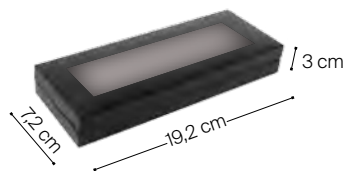

* 00066
 See-through Gift Box for 1 or 2 items

- EN** > * Available for all writing instruments, except graphite pencils.
- FR** > * Disponible pour tous les articles d'écriture, à l'exception des crayons à papier.
- ES** > * Disponible para todos los productos de escritura excepto lápices.
- DE** > * Erhältlich für alle Schreibgeräte außer Bleistifte.
- IT** > * Disponibile per tutti gli strumenti da scrittura eccetto matite.



60010
Box for 10 units



60013
Optional packaging
Count Box for
10 units



60011
Optional packaging
Count Box for
10 units

60010

Standard Packaging Box for 10 units

- EN >** Available for BIC® Styl'it Luxury Lighter Case, BIC® Styl'it Luxury Soft Lighter Case and BIC® Styl'it Luxury Metallic Case.
- FR >** Disponible pour BIC® Styl'it Luxury Lighter Case, BIC® Styl'it Luxury Soft Lighter Case et BIC® Styl'it Luxury Metallic Case.
- ES >** Disponible para BIC® Styl'it Luxury Lighter Case, BIC® Styl'it Luxury Soft Lighter Case y BIC® Styl'it Luxury Metallic Case.
- DE >** Erhältlich für BIC® Styl'it Luxury Feuerzeughülle, BIC® Styl'it Luxury Soft Feuerzeughülle und BIC® Styl'it Luxury Metallic Case.
- IT >** Disponibile per BIC® Styl'it Luxury Lighter Case, BIC® Styl'it Luxury Soft Lighter Case e BIC® Styl'it Luxury Metallic Case.

60011

Optional packaging Count Box for 10 units

- EN >** Available for BIC® J23, BIC® J26, BIC® J38 and BIC® J39 Lighter.
- FR >** Disponible pour BIC® J23, BIC® J26, BIC® J38 et BIC® J39 Lighter.
- ES >** Disponible para BIC® J23, BIC® J26, BIC® J38 y BIC® J39 Lighter.
- DE >** Erhältlich für BIC® J23, BIC® J26, BIC® J38 und BIC® J39 Feuerzeuge.
- IT >** Disponibile per BIC® J23, BIC® J26, BIC® J38 e BIC® J39 Lighter.

60013

Optional packaging Count Box for 10 units

- EN >** Available for BIC® J25 lighter, BIC® 3D Case.
- FR >** Disponible pour BIC® J25 lighter, BIC® 3D Case.
- ES >** Disponible para BIC® J25 lighter, BIC® 3D Case.
- DE >** Erhältlich für BIC® J25 Feuerzeuge, BIC® 3D Case.
- IT >** Disponibile per BIC® J25 lighter, BIC® 3D Case.



00037
Standard
Packaging for BIC®
Lighter Cases.
Box of 50 units



Standard Packaging
BIC® Lighters.
Tray of 50 units

00037
Standard Packaging for BIC® Lighters Cases.
Box of 50 units

- EN >** Available for BIC® Clip Case, BIC® Styl'it Fashion, BIC® Aluminium Flat Lighter Case.
- FR >** Disponible pour BIC® Clip Case, BIC® Styl'it Fashion, BIC® Aluminium Flat Lighter Case.
- ES >** Disponible para BIC® Clip Case, BIC® Styl'it Fashion, BIC® Aluminium Flat Lighter Case.
- DE >** Erhältlich für BIC® Clip Case, BIC® Styl'it Fashion, BIC® Aluminium Flat Feuerzeughülle.
- IT >** Disponibile per BIC® Clip Case, BIC® Styl'it Fashion, BIC® Aluminium Flat Lighter Case.

Standard Packaging BIC® Lighters.
Tray of 50 units

General information

FILE INFORMATION

- Please submit your artwork in one of the following formats:
- Electronic file with the graphic design (artwork).
 - Separate file for the text. For individual laser engraving please provide texts only in Excel® format (.xls)

ARTWORKS FEATURES

- Please submit your artwork in one of the following formats:
- JPG / 350 dpi not compressed (only for images, no texts)
 - PDF / outlined
 - Illustrator® CC / outlined
 - Photoshop® CC / with layers
 - ZIP files

In order to facilitate a fluid order process and obtain an appropriate final result, it is important to provide us the information in one of the above listed formats. Should the customer's design not fit into our imprint area, we will modify it accordingly.

Typefaces:

- All the typefaces must be converted to an artwork. Verify the minimum type sizes & line weights. Please, contact Customer Service for further information.

SPECIAL FOR WRITING PRODUCTS

Available imprint area depends on required printing technique.

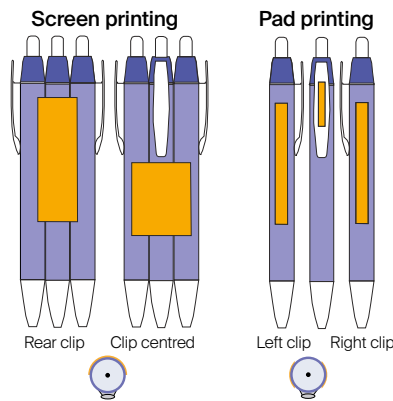

SPECIAL FOR DIGITAL LIGHTERS (J25, J23, J26, J38 & J39)

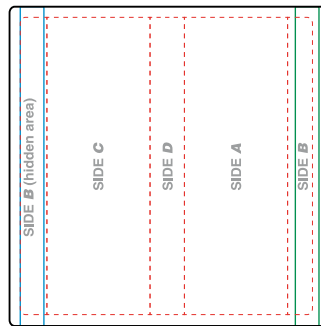

If a direct PMS colour is desired a fifth colour may be chosen from the aforementioned Guide for an additional charge. For more information on achieving the closest colour match for imprints on different products within our catalogue please contact our Customer Service Department

FR > Informations générales

Informations concernant les fichiers

Fichiers à fournir :

- un fichier électronique avec le dessin graphique
 - et un fichier différent pour le texte.
- Pour un marquage au laser individuel, les textes devront être fournis uniquement sous format Excel® (.xls).

Propriétés du matériel graphique

Envoyez-nous votre matériel graphique dans un des types de fichiers suivants :

- JPG / 350 dpi sans compresser à la taille réelle de marquage (seulement images, sans texte)
- PDF / vectorisé
- Illustrator® CC / vectorisé
- Photoshop® CC / avec les couches
- Fichiers ZIP

Il est important que vous nous fassiez parvenir les informations dans l'un de ces formats afin de traiter au mieux votre commande et d'obtenir un résultat final optimal.

Si la création du client ne rentre pas dans notre format, nous modifierons en conséquence.

Type de caractères.

- Tous les types de caractères doivent être converti en un arte final. Vérifiez les tailles minimales des types et les épaisseurs de trait. Veuillez contacter le service clientèle pour plus d'informations.

Special pour les produits d'écriture

La zone d'impression disponible dépend de la technique d'impression requise.

Special pour les briquets (J25, J26, J38 et J39)

Pour toute demande de couleur directe Pantone, nous pouvons proposer une impression avec une 5e couleur de ce Guide, à un prix majoré. Pour plus d'informations sur la manière d'obtenir la couleur correspondante la plus proche pour des impressions sur différents produits de notre catalogue, veuillez contacter notre service client.

ES > Información general

Información sobre archivos

En cualquier caso, los archivos deben ser dos:

- un archivo electrónico con el diseño gráfico (creatividad)
 - y otro archivo distinto para el texto.
- Para un grabado en láser, facilite los textos únicamente en formato Excel® (.xls).

Propiedades del material gráfico

Envíenos su material gráfico en alguno de los siguientes tipos de archivo:

- JPG / 350 dpi sin comprimir al tamaño real de impresión (sólo imágenes, sin texto)
- PDF / vectorizado
- Illustrator® CC / vectorizado
- Photoshop® CC / con capas
- Archivos ZIP

Es importante que nos proporcione la información en uno de estos formatos para agilizar su pedido y para obtener un resultado final adecuado.

Si el diseño del cliente no encaja correctamente en el área de impresión, lo modificaremos consecuentemente.

Fuentes:

- Todos los tipos de letra se deben convertir en un arte final. Verifique los tamaños de los tipos mínimos y grosores de línea.

Por favor, contacte con Atención al Cliente para más información.

Special para Instrumentos de Escritura

Área de impresión disponible según la técnica de impresión.

Special para encendedores en digital (J25, J26, J38 & J39)

En el caso de querer un color directo, podemos ofrecer la impresión con un 5º color de dicha Guía. Para una mejor coincidencia de color entre los diferentes productos de nuestro catálogo, póngase en contacto con nuestro departamento de Atención al Cliente.

DE > Allgemeine Information

Druckvorlageanforderungen

Bitte senden Sie uns folgende Dateien:

- reprofähige Druckvorlagen als Grafik
- Separate Textdatei.

Für personalisierte Lasergravuren müssen die Texte im Excel®-Format (.xls) eingeschickt werden.

Technische Daten der Grafikdateien

Bitte schicken Sie Ihre Grafiken in einem dieser Formate:

- JPG / 350 dpi nicht komprimiert und in der tatsächlichen Druckgröße (nur Bilddaten, kein Text)
- PDF / Vektordatei
- Illustrator® CC / Vektordatei
- Photoshop® CC / mit Ebenen
- ZIP format

Wir bitten um Zusendung der Daten in den angegebenen Formaten. Damit können wir den Auftrag schnellstmöglich bearbeiten und ein optimales Druckergebnis erreichen. Sofern der Entwurf des Kunden nicht in unseren Druckbereich passt, werden wir ihn entsprechend anpassen.

Schriftarten:

- Alle Schriftarten müssen in eine Vorlage umgewandelt werden. Überprüfen Sie die Mindestschriftgrößen und Linienstärken. Für weitere Informationen kontaktieren Sie bitte unseren Kundenservice

Speziell für Schreibprodukte

Die mögliche Werbefläche ist von der angeforderten Drucktechnik abhängig.

Speziell für digitale Feuerzeuge (J25, J26, J38 und J39)

Wenn Sie ausdrücklich eine Pantone-Farbe wünschen, können Sie zusätzlich eine fünfte Farbe aus unserem verfügbaren Repertoire auswählen. Hierfür wird ein Aufpreis berechnet. Weitere Informationen zur Farbangleichung bei Bestellung verschiedener Produkte erhalten Sie von Ihrem Kundenservice.

IT > Informazioni Generali

Informazione sui file

Sempre, per quanto riguarda i file, i documenti si devono inviare come di seguito:

- un file elettronico con il design grafico (creatività)
 - ed un altro file separato per il testo.
- Per un'incisione a laser singola, consegnare i testi esclusivamente in formato Excel® (.xls).

Proprietà del materiale grafico

Inviatoci il vostro materiale grafico in uno dei seguenti tipi di file:

- JPG / 350 dpi non compresso e nel formato reale della stampa (solo per le immagini, non per il testo)
- PDF / vettorizzato
- Illustrator® CC / vettorizzato
- Photoshop® CC / con livelli
- file ZIP

E' importante che le informazioni vengano mandate in uno dei formati indicati al fine di svellire l'ordine ed ottenere un miglior risultato finale.

Nel caso in cui il design del cliente non si adatti all'area di stampa, verrà adattato di conseguenza.

Caratteri:

- Tutti i caratteri devono essere convertiti in immagine. Verificare le dimensioni minime del carattere e gli spessori del tratto.











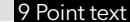

Speciale per prodotti di scrittura















L'area di stampa disponibile dipende dalla tecnica desiderata.





Speciale per accenditori digitali (J25, J26, J38 e J39)

Se si desidera un colore preciso, potrebbe essere scelto un quinto colore dalla suddetta guida a un costo aggiuntivo. Per maggiori informazioni sulla migliore corrispondenza del colore di stampa per i vari prodotti del nostro catalogo, contattare il nostro Servizio Clienti.

TECHNICAL PARAMETERS FOR EACH TYPE OF PRINTING

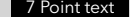
	SCREEN PRINTING/ PAD PRINTING	HOT STAMPING / DEBOSSING	LASER ENGRAVING
Minimum positive text	6 pt (2.1 mm) 	10 pt (3.5 mm) 	6 pt (2.1 mm) 
Minimum negative text	9 pt (3.1 mm) 	15 pt (5.25 mm) 	NOT RECOMMENDED
Minimum thickness for positive lines	0.4 pt (0.14 mm) 	1.5 pt (0.5 mm) 	0.3 pt (0.1 mm) 
Minimum thickness for negative lines	0.5 pt (0.176 mm) 	2 pt (0.706 mm) 	0.5 pt (0.17 mm) 
Minimum thickness for half tones	1.5 pt (0.5 mm) 	NOT POSSIBLE	NOT POSSIBLE
Percentage half tone	50% 		

	STICKY NOTES	DIGITAL / DIGITAL TRANSFER
Minimum positive text	4 pt (1.4 mm) 	4 pt (1.4 mm) 
Minimum negative text	5 pt (1.75 mm) 	7 pt (2.4 mm) 
Minimum text for half tone	7 pt (2.4 mm) 	1.5 pt (0.5 mm) 
Minimum thickness for positive lines	0.3 pt (0.1 mm) 	0.25 pt (0.08 mm) 
Minimum thickness for negative lines	0.5 pt (0.17 mm) 	0.5 pt (0.17 mm) 
Minimum thickness for lines in half tone	0.5 pt (0.17 mm) 	0.5 pt (0.17 mm) 
Minimum half tone values	C: 5% / M: 5% / Y: 15% / K: 5% 	C: 8% / M: 8% / Y: 12% / K: 8% 

	britePix™
Minimum positive text	6 pt (2.1 mm) 
Minimum negative text	7 pt (2.4 mm) 
Minimum thickness for positive lines	0.4 pt (0.14 mm) 
Minimum thickness for negative lines	0.5 pt (0.17 mm) 
Minimum thickness for half tones	1 pt (0.35 mm) 
Percentage half tone	

SPECIAL IMPRINT COLOURS

NOTEBOOKS

Hot-stamping colours

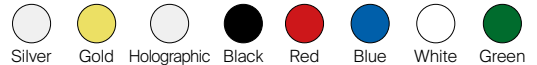

EXACT COLOURS WITH WHITE UNDERLAYER REQUIREMENT

- There are some colour references that need a white underlayer when we print on dark surfaces (Black, Dark blue, Red) in order to get the result required by the customer.
- In case the product only allows 1 imprint, the Customer Service representative will inform the customer that the final imprinted colour will be approximate.
- In case the product allows an additional imprint, the Customer Service representative will offer the customer the possibility to obtain the exact colour WITH a white underlayer (at extra cost).

FR > Paramètres techniques pour chacun des types d'impression

SERIGRAPHIE / TAMPOGRAPHIE ESTAMPAGE / EMBOSSEAGE LASER
STICKY Notes
DIGITAL / TRANSFERT DIGITAL britePix™
 Texte positif minimum
 Texte négatif minimum
 Épaisseur minimale des lignes positives
 Épaisseur minimale des lignes négatives
 Épaisseur minimale des demi-teintes
 Pourcentage de demi-teinte
 Valeur minimale de demi-teinte
Couleurs spéciales d'impression
Notebooks
 Couleurs d'estampage à chaud
Couleurs exactes qui requièrent une couche de fond blanche
 Plusieurs références de couleur requièrent une couche de fond blanche lorsqu'elles sont imprimées sur des surfaces foncées (noir, bleu foncé, rouge) pour pouvoir obtenir le résultat souhaité par le client.
 • Si le produit permet seulement 1 impression, le représentant du service clients devra prévenir le client que le résultat de la couleur imprimée sera approximatif.
 • Si le produit permet une impression supplémentaire, le représentant du service clients offrira au client la possibilité d'obtenir la couleur exacte AVEC une couche de fond blanche (moyennant majoration du prix).

ES > Parámetros técnicos para cada tipo de impresión

SERIGRAFÍA / TAMPOGRAFÍA HOTSTAMPING / GRABADO EN RELIEVE LASER
STICKY Notes
DIGITAL / TRANSFERENCIA DIGITAL britePix™
 Texto mínimo positivo
 Texto mínimo negativo
 Grosor mínimo para líneas positivas
 Grosor mínimo para líneas negativas
 Grosor mínimo de marca de agua
 Porcentajes de marca de agua
 Valores mínimos de marca de agua
Impresión de colores especiales
Notebooks
 Colores para Hot-stamping
Colores exactos que requieren una pasada de blanco debajo
 Hay varias referencias de colores que necesitan una pasada de blanco debajo cuando son impresos sobre superficies oscuras (negro, azul oscuro, rojo) para obtener el resultado que requiere el cliente.
 • En caso que el producto solo admita 1 color de marcado, el representante de atención al cliente informará al cliente de que el resultado será aproximado.
 • En caso que el producto permita una pasada más, el representante de atención al cliente ofrecerá al cliente la posibilidad de obtener el color exacto imprimiendo una pasada de blanco (con extra coste).

DE > Technische Parameter für jeden Typendruck

SIEBDRUCK / TAMPONDRUCK HOTSTAMPING / PRÄGUNG LASERGRAVUR
STICKY Notes
DIGITAL / DIGITALDRUCK britePix™
 Minimum positiver Text
 Minimum negativer Text
 Mindeststärke für Linien im Positivdruck
 Mindeststärke für Linien im Negativdruck
 Mindeststärke für Halbtöne
 Prozentsatz Halbtöne
 Mindestwerte für Halbtöne
Spezielle Werbeaufdruckfarben
Notebooks
 Farben für Heißprägung
Farbgetreue Farben, für die ein weißer Untergrund erforderlich ist
 Es gibt verschiedene Farbreferenzen, für die ein weißer Untergrund erforderlich ist, wenn auf dunklen Flächen gedruckt werden soll (schwarz, dunkelblau, rot), um das vom Kunden gewünschte Resultat zu erzielen.
 • Falls für das Produkt nur ein Aufdruck möglich ist, wird ein Mitarbeiter des Kundendienstes den Kunden darüber informieren, dass die aufgedruckte Farbe nur annähernd dem gewünschten Farbton entspricht.
 • Ist für das Produkt ein zusätzlicher Aufdruck möglich, wird der Kundendienstmitarbeiter dem Kunden das Angebot machen, die gewünschte Farbe (gegen Aufpreis).

IT > Parametri tecnici per ciascun tipo di stampa

SERIGRAFIA / TAMPOGRAFIA STAMPA A CALDO/ BASSORILIEVO LASER
STICKY Notes
DIGITALE / TRASFERIMENTO DIGITALE britePix™
 Testo positivo minimo
 Testo negativo minimo
 Spessore minimo per linee positive
 Spessore minimo per linee negative
 Spessore minimo per mezzi toni
 Percentuale mezzo tono
 Valori minimi mezzo tono
Colori stampa speciale
Notebooks
 Colori stampa a caldo
Colori precisi con necessità di sfondo bianco
 Alcuni codici di colore richiedono uno sfondo bianco in caso di stampa su superfici scure (nero, blu scuro, rosso) in modo da ottenere il risultato desiderato.
 • Se il prodotto consente solo 1 stampa, il referente del servizio clienti informerà che il colore finale della stampa potrebbe essere leggermente diverso.
 • Se il prodotto consente un'ulteriore stampa, il referente del servizio clienti offrirà la possibilità di ottenere il colore esatto CON uno sfondo bianco (con un supplemento di prezzo).

STICKY NOTES General information

Due to the nature of BIC® Sticky Notes paper, resulting imprints will appear as matte, without shine. The reference colours chosen must be selected from the PMS Guide. **BIC® Sticky Notes are printed using a 4-colour process (CMYK), a technique which adjusts the imprint colour to match the references in the PMS Guide.** As such, the resulting imprint may differ slightly from the selected PMS reference. If a direct PMS is desired a fifth colour may be chosen from the aforementioned Guide for an additional charge. For more information on achieving the closest colour match for imprints on different products within our catalogue please contact our Customer Service Department.



• IMPRINTING AREA

- Despite the fact that it's possible to print on the upper part of the pad (the adhesive area) we can only print up to 60% colour in this area.
- Apart from the adhesive area, we recommend only printing 30% of the print area of the product to leave space for note taking and avoid poor ink absorption.

• SHADOW

- **Shadows or phantom imprints are available at no extra charge.** Photographs, line drawings and large logos that cover most of the space at the centre look best.
- As they are very light, text and phone numbers are not recommended as phantoms.
- The most appealing shades are about 10%.

• DIE CUT SPECIAL SHAPES AND OTHER CUSTOMISATIONS

- **Be the most original!** Request your BIC® Sticky Notes Adhesive pad with your desired custom-made shape or customise with your own logo the backsheet of the pads. Please check the conditions of these special customisations with your usual contact person.

FR > Informations BIC® Sticky Notes

En raison de la nature du papier BIC® Sticky Notes, les résultats à l'impression auront un aspect mat, et non brillant. Les couleurs de référence choisies doivent être sélectionnées sélectionnées dans le guide PMS. Les BIC® Sticky Notes sont imprimés en quadrichromie (CMYK), une technique qui ajuste la couleur d'impression afin de correspondre aux références du guide PMS. Pour toute demande de couleur directe PMS, nous pouvons proposer une impression avec une 5e couleur de ce Guide, à un prix majoré. Pour plus d'informations sur la manière d'obtenir la couleur correspondante la plus proche pour des impressions sur différents produits de notre catalogue, veuillez contacter notre service client.

Zone d'impression

Même si la partie supérieure du bloc de papier peut être imprimée (la partie adhésive), elle peut seulement être imprimée jusqu'à 60 % d'encre totale.

Indépendamment de la zone adhésive, nous recommandons d'imprimer uniquement 30 % de la surface du produit afin de laisser de l'espace pour la prise de notes et d'éviter ainsi d'éventuelles problèmes d'adhésion de l'encre sur le papier.

Formes spéciales d'estampage et autres personnalisations

Soyez le plus original ! Demandez vos blocs adhésifs BIC® Sticky Notes avec votre forme personnalisée ou adaptez-les en incluant votre propre logo sur le verso des blocs. Veuillez vérifier les conditions de ces formules spéciales avec votre contact habituel.

Impression Shadow ou fantôme

Les impressions Shadow ou fantôme sont disponibles sans surcoût. Les photographies, les dessins ou logos de grande taille qui couvrent la majorité de la surface centrale ont un meilleur rendu. Comme ces impressions sont très claires, les textes et numéros de téléphone ne sont pas recommandés en Shadow ou fantôme. Les meilleurs rendus sont obtenus à partir d'images tramées aux environs de 10 %.

ES > Información BIC® Sticky Notes

Debido a la naturaleza del papel para BIC® Sticky Notes el resultado impreso será mate, nunca brillo. Los colores de referencia solicitados deben ser de la Guía PMS. El proceso de impresión para BIC® Sticky Notes es en cuatricromía (CMYK), y el resultado impreso puede variar de la referencia pantone solicitada. En el caso de querer un color directo, podemos ofrecer la impresión con un 5º color de dicha Guía. Para una mejor aproximación de color entre los diferentes productos de nuestro catálogo, póngate en contacto con nuestro departamento de Atención al Cliente.

Área de impresión

A pesar de que la parte superior del taco de papel se puede imprimir (la parte adhesiva), sólo se puede imprimir hasta un 60% de tinta total.

Además de la zona adhesiva, recomendamos imprimir únicamente el 30% de la zona correspondiente al taco de papel, con el fin de dejar más espacio libre para tomar notas y evitar una absorción incorrecta de la tinta.

Formas especiales y otras personalizaciones

¡Sé el más original! Solicita tus BIC® Sticky Notes con la forma deseada o personaliza con tu propio logo la hoja trasera de los blocs adhesivos. Por favor, consulta las condiciones de estas personalizaciones especiales con tu persona de contacto habitual

Impresión "marca de agua"

Podemos ofrecerte "marcas de agua" sin coste adicional alguno. Las fotografías, los dibujos lineales o los logotipos de gran tamaño que cubren la mayor parte del espacio central son las opciones que ofrecen mejores resultados. Puesto que la impresión de "marcas de agua" es muy clara, no se recomienda para números de teléfono o texto. Las mejores "marcas de agua" son aquellas que se imprimen en torno al 10% de intensidad.

DE > Information BIC® Sticky Notes

Aufgrund der Papier-Beschaffenheit der BIC® Sticky Notes, fällt das Druckergebnis matt aus. Die gewünschten Farbreferenzen wählen Sie aus der PMS Farbpalette aus. BIC® Sticky Notes werden im Offset-Druck nach Euroskala (CMYK) bedruckt. Dank dieser Technik wird das Farbergebnis an die gewünschten Pantone-Referenzen angenähert. Wenn Sie ausdrücklich eine Pantone-Farbe wünschen, können Sie zusätzlich eine fünfte Farbe aus unserer verfügbaren Repertoire auswählen. Hierfür wird ein Aufpreis berechnet. Weitere Informationen zur Farbangleichung bei Bestellung verschiedener Produkte erhalten Sie von Ihrem Customer Service.

Druckbereich

Obwohl es möglich ist auf dem oberen, dem Haftbereich des BIC® Sticky Notes zu drucken kann nur bis zu maximal 60% der Druckfarbe aufgebracht werden.

Außerhalb des Haftbereichs sollte maximal 30% der Fläche bedruckt werden, um möglichst viel Platz für Notizen frei zu lassen und das Risiko unvollständiger Aufnahme der Schreibfarbe zu vermeiden.

Speziell gestanzte Formen und andere kundenspezifische Anpassungen

Seien Sie der Originellste! Bestellen Sie Ihre BIC® Sticky Notes Haftnotizen in der von Ihnen gewünschten Form oder individualisieren Sie die Rückseite der Pads mit Ihrem eigenen Logo. Bitte sprechen Sie über die Möglichkeiten für diese speziellen kundenspezifischen Anpassungen mit Ihrem zuständigen Ansprechpartner.

Shadow-Druck

Flood- und Shadowdruckeffekte sind ohne Aufpreis erhältlich. Fotos, Zeichnungen oder große Logos, die einen Großteil der Grundfläche bedecken, eignen sich dafür am besten. Texte und Telefonnummern sind für Hintergrunddrucke nicht geeignet, da sie zu schwierig zu erkennen sind. Beste Resultate werden mit 10% Rasterung erzielt.

IT > Informazioni BIC® Sticky Notes

Data la natura della carta usata per BIC® Sticky Notes il risultato di stampa sarà opaco, mai brillante. I colori di riferimento richiesti dovranno provenire dalla guida PMS. Il processo di stampa di BIC® Sticky Notes è la quadricromia (CMYK) ed il risultato può variare rispetto al colore di riferimento richiesto. Se si desidera un colore preciso, potrebbe essere scelto un quinto colore dalla suddetta guida a un costo aggiuntivo. Per maggiori informazioni sulla migliore corrispondenza del colore di stampa per i vari prodotti del nostro catalogo, contattare il nostro Servizio Clienti.

Area di stampa

Anche se la parte superiore del blocchetto si può stampare (la parte adesiva) si raccomanda di non usare quest'area per una stampa a tutto colore. A parte la zona adesiva, si raccomanda di stampare unicamente il 30% della superficie del prodotto, per lasciare più spazio libero per prendere appunti ed evitare un assorbimento irregolare dell'inchiostro.

Forme speciali fustellate e altre personalizzazioni

Sii il più originale! Richiedi il tuo blocco note adesivo BIC® Sticky Notes con la forma realizzata su misura per te, oppure personalizza con il tuo logo il lato posteriore del blocco note. Ti invitiamo a verificare le condizioni di queste speciali personalizzazioni con il tuo referente abituale.

Effetto fantasma

Possiamo stampare effetti fantasma o sfumature senza costi aggiuntivi. Le fotografie, i disegni lineari o i logotipi di grandi dimensioni che coprono la maggior parte dello spazio centrale sono le opzioni che danno i migliori risultati. Dal momento che le stampe ad effetto fantasma sono molto chiare, non sono consigliabili per numeri di telefono o testo. Gli effetti fantasma migliori sono quelli che si stampano a circa il 10%.

FR > Informations générales

Options spéciales

- Puffy glitter: texture avec paillettes colorées
Puffy printing: Une personnalisation soulignée par notre encre « Puffy », pour donner un effet de relief à votre logo.
4-colour process: Permet la reproduction d'images de haute résolution...

Abréviations

- SP = Sérigraphie
LE = Gravure laser
4CP = Procédé de quadrichromie
HS = Estampage
DB = Embossage
PD = Tamponographie
DT = Transfert digital
DG = Digital
BP = britePix™
BP Texture = britePix™ Texture
OT = Transfert offset
MOQ = Offset transfert minimale de commande

Ink colours

- Encre noire
Encre bleue claire
Encre bleue foncée
Encre rouge
Encre verte claire
Encre verte foncée
Encre rose
Encre violette
Encre fluo

Modes d'écriture

- Bille
Stylo Plume /
Surligneur
Marqueur
Porte-mine
Crayon
Stylo à bille roulante
Gel
Feutre pointe fine
Tipp-Ex®

BIC® Easy-Glide system option Offre une encre qui est 35 % plus lisse et plus épaisse que votre stylo à bille actuel.

Autres symboles

- Mix&Match: Centaines de couleurs de composants en stock pour la personnalisation complète des instruments d'écriture.
PMS Service: Choisissez la couleur PMS pour des décorations les mieux adaptées à votre logo.
QR CODE: scannez le QR code et visionnez la vidéo.
48 hour Service: 48 h disponible
Mobius loop: Le produit contient des matériaux recyclés.
Renewable Resource: Produit fabriqué avec des matériaux respectant l'environnement, utilisant des matériaux renouvelables de conifères (polymères cellulosiques).
Pays d'origine
APP: Téléchargez l'application de BIC® Graphic et scannez les les pages où figure cette icône.
Nouveautés / Nouveaux colors
Regardez!: Laissez-vous surprendre par la finition de ce produit.
Touchez!: Laissez-vous surprendre par le toucher de ce produit.
EN 13869: Règlement de sécurité des enfants pour les briquets.
ISO 22702: Cette norme certifie la qualité de tous les briquets à usages multiples.
EN 9994: Normes de sécurité internationales pour les briquets.
Sticky Notes: Nombre de pages
Notebooks: Nombre de pages
Informations sur l'emballage
BIC® Boy: Iconic BIC® Boy est embossé
Bande lubrifiante
Nombre de lames
BIC® Mega Lighter: usage quotidien du BIC® Mega Lighter
Nombre d'allumages
Tube de gel à raser 10 ml uniquement disponible pour l'Autriche, la Belgique, la France, l'Allemagne, l'Italie, le Luxembourg, les Pays-Bas, le Portugal, la Roumanie, l'Espagne, la Suisse et le Royaume-Uni.
Exclusive Articles exclusifs disponibles seulement dans notre catalogue.
Bluetooth®
Fréquence
Impédance
Sensibilité
Diamètre aimant
Sans câbles
Autonomie de la batterie
Longueur du cordon
Résistant à l'eau
Puissance
Antichoc
Point par pouces
Entrée/sortie alimentation
Résolution du vidéo
Résolution du vidéo
Objectif du caméra
Dimension du écran

Dimensions

Les dimensions publiées de tous les produits correspondent à la taille maximale, quelle que soit la position du dessin.

ES > Símbolos y abreviaturas

Técnicas de impresión

- Puffy glitter: Textura de color brillante
Impresión Puffy: Resalta tu personalización cándulo efecto relieve a tu logo.
4-colour process: Permite la reproducción de imágenes de alta resolución.
Tinta metálica: Tinta metálica sin ningún coste adicional.
BR: Acabado brillante
Glow in the dark: Haz que tu marca brille incluso en la oscuridad.
Acabado metálico: Crea efectos metálicos en imágenes o fondos.
Acabado holográfico: Convierte tu logo en una imagen tridimensional usando hologramas.
Mate: Acabado mate.
UVI: Acabado super brillante.
Sandy: Textura granulada con efecto arena.
Digital: Cuatricromía de alta definición. 360° en el cuerpo entero.
britePix™: Impresión a todo color con resultados fotográficos de alta calidad que asegura una impresión duradera de su logo.
britePix™ Texture: britePix™ Texture es un añadido premium al concepto britePix™ - ahora no solo puedes verlo sino que también puedes sentirlo.
britePix™ personalisation: Personalización britePix™. Personaliza cada unidad en el mismo pedido britePix™.

Abreviaturas

- SP = Serigrafía
LE = Impresión a láser
4CP = Proceso de cuatricromía
HS = Hot stamping
DB = Grabado en relieve
PD = Tamponografía
DT = Transfencia digital
DG = Digital
BP = britePix™
BP Texture = britePix™ Texture
OT = Transfencia offset
MOQ = Cantidad mínima de pedido

Colores de tinta

- Tinta negra
Tinta verde claro
Tinta azul claro
Tinta azul oscuro
Tinta roja
Tinta morada
Tinta fluo

Modos de escritura

- Bolígrafo
Pluma
Resaltador
Marcador
Portaminas
Lápiz
Roller
Gel
Escritura fina
Tipp-Ex®

BIC® Easy-Glide system option: 35% más fluido y más intenso que nuestro bolígrafo actual.

Otros símbolos

- Mix&Match: Cientos de componentes de instrumentos de escritura para una completa personalización.
PMS Service: Elija para los atributos, el colour

- PMS que mejor se adapte a su logo
Código QR: Escanea el código QR y mira el video
48 hour: Servicio 48 h disponible
Mobius loop: El producto contiene material reciclado.
Renewable Resource: Producto elaborado de material ecológico fabricado con materiales de coníferas naturales renovables (polímeros celulósicos).
Pais de origen
APP: Descarga la aplicación de BIC® Graphic y escanea las páginas que tengan este icono.
Nuevo / Nuevos colores
Irritalo!: Sorpréndete por el acabado de este producto.
Tócalo!: Sorpréndete por el tacto de este producto.
EN 13869: Regulaciones Europeas para Encendedores con seguridad para niños.
ISO 22702: This standard certifies the quality of all utility lighters.
ISO 9994: Normas internacionales de seguridad para encendedores.
Sticky Notes: Número de hojas.
Notebooks: Número de hojas.
Información de emvasado
BIC® Boy: El icónico BIC® Boy con relieve aquí.
Banda lubricante.
Número de hojas
BIC® Mega Lighter: Usa el BIC® Mega Lighter diariamente.
Numero de encendidos
Gel de afeitado de 10ml sólo disponible para Austria, Bélgica, Francia, Alemania, Italia, Luxemburgo, Países Bajos, Portugal, Rumania, España, Suiza y Reino Unido.
Exclusivo Productos exclusivos sólo disponibles a través de nuestro catálogo.
Bluetooth®
Frecuencia
Impedancia
Sensibilidad
Diametro del imán
Sin cables
Autonomia de la batería
Longitud cable
Resistente al agua
Potencia
A prueba de golpes
Puntos por pulgada
Entrada/salida corriente eléctrica
Resolución video
Resolución cámara
Objetivo cámara
Dimensión pantalla

Dimensiones

Las dimensiones publicadas en cada producto corresponden a su tamaño máximo, independientemente de la posición que muestre el dibujo.

DE > Symbole & abkürzungen

Spezielle Möglichkeiten

- Puffy glitter: Farbige Glitter-Textur
Puffy printing: Eine überzeugende Personalisierung mit unserer "Puffy"-Tinte, die Ihrem Logo einen Relief-Effekt verleiht.
4-Farbdruck: Aufdruck von Bildern mit hoher Auflösung, ideal für Fotodrucke.
Metallisch-Tinte: Verteilen Sie Ihre Botschaft ohne Aufpreis eine besondere Wertigkeit mit Metallisch-Drucktinten.
BR: Digitaldruck mit Glanzeffekt.
Glow in the dark: Lassen Sie Ihre Marke erstrahlen, selbst in der Dunkelheit.
Metallisch-Ausführung: Drucktinten mit hoher Auflösung, ideal für Fotodrucke.
Holographische Ausfertigung: Verwandeln Sie Ihr Logo in ein dreidimensionales Bild durch Hologrampe.
Matte: Digitaldruck mit mattem Finish.
UV: Digitaldruck mit Hochglanzeffekt.
Sandy: Sandpapier-Effekt mittels feinkörniger Oberfläche.
Digital: Hochauflösender Vierfarb-Process. 360° Rundumdruck auf dem ganzen Schaft.
britePix™: Ihre Nachricht kann nun in voller Farbe mit grafscher Brillanz gedruckt werden, wobei ein dauerhafter, lebendiger und bleibender Eindruck Ihres Logos sichergestellt wird.
britePix™ Texture: britePix™ Texture ist eine neue Ergänzung für unser britePix™ Druckkonzept - man kann die Farben jetzt nicht nur sehen, man kann sie auch fühlen!
britePix™ Personalisierung: brite Pix™ Personalisierung Personalisieren Sie Ihre brite Pix Bestellung. Geben Sie jedem Artikel Ihrer Bestellung eine individuelle Note.

Abkürzungen

- SP = Siebdruck
LE = Lasergravur
4CP = 4-Farbdruck
HS = Hotstamping
DB = Prägung
PD = Tampondruck
DT = Digitaldruck
DG = Digital
BP = britePix™
BP Texture = britePix™ Texture
OT = Offset-Transferdruck
MOQ = Mindestbestellmenge

Ink colours

- Schwarze Tinte
Hellblaue Tinte
Dunkelblaue Tinte
Rote Tinte
Hellgrüne Tinte
Dunkelgrüne Tinte
Rosa Tinte
Violette Tinte
Fluoreszierende Tinte

Schreibtechniken

- Kugelschreiber
Füllfederhalter
Leuchtmarker
Permanent Marker
Druckbleistift
Bleistift
Rollerball
Gelschreiber
Finelliner
Tipp-Ex®

BIC® Easy-Glide system option 35% weicher und präziser als eine herkömmliche Mine.

Andere Symbole

- Mix&Match: Hunderte von Farben bei den Schreibgeräten-Komponenten auf Lager.
PMS Service: Wählen Sie die PMS-Farbe für Verzierungen, die am besten zu Ihrem Logo passt.
QR CODE: Scannen Sie den QR Code und sehen Sie sich das Video an.
48 Stunden Service
Mobius loop: Das Produkt enthält recyceltes Material.
Renewable Resource: Das Produkt ist zu aus umweltfreundlichem Material hergestellt, indem natürliche, erneuerbare Weichholz-Materialien verwendet wurden (Polymere auf Cellulose-Basis).
Herkunftsland
APP: Laden Sie sich die BIC Graphic App herunter und scannen Sie die mit diesem Symbol gekennzeichneten Artikel.
Neue / Neue Farben
Schauen Sie mal!: Lassen Sie sich von dieser aller Feuerzeuge.
Übern Sie mal! Dieses Produkt wird Sie überraschen!
EN 13869 Europäische Kindersicherheitsnorm für Feuerzeuge.
ISO 22702 Dieser Standard zertifiziert die Qualität aller Feuerzeuge.
ISO 9994 Internationale Sicherheitsstandards für Feuerzeuge.
Sticky Notes Anzahl der Blätter.
Notebooks Anzahl der Blätter.
Information zu Verpackungen
BIC® Boy: Der ikonische BIC®-Boy ist hier aufgeführt.
Gleitstreifen
Anzahl der Klängen
BIC® Mega Lighter: Verwendung des BIC® Mega Lighters in Notsituationen.
Anzahl der Zündungen
Rasiergelbe 10 ml nur erhältlich in Österreich, Belgien, Frankreich, Deutschland, Italien, Luxemburg, Niederlande, Portugal, Rumänien, Spanien, Schweiz und Vereinigtem Königreich.
Exklusivartikel Markiert Artikel, die Sie ausschließlich aus unserem Katalog bestellen können.
Bluetooth®
Frequenz
Scheinwiderstand
Empfindlichkeit
Magnetchmesser
Kabellos
Akkulauzeit
Kabellänge
Wasserabweisend
Leistung
Stoffest
Punkte pro Zoll
Eingang-/Ausgangsleistung
Videoauflösung
Kameraauflösung
Kameraobjektiv
Bildschirmgröße

Abmessungen

Die Abmessungen, die für jedes Produkt angegeben werden, entsprechen dessen maximaler Größe, in Unabhängigkeit von der Zeichnungsposition.

IT > Simboli & abbreviazioni

Opzioni speciali

- Puffy glitter: Texture con glitter colorati
Puffy printing: Una personalizzazione evidenziata con il nostro inchiostro "Puffy" per dare un effetto a rilievo al tuo logo.
4-colour process: Consente la riproduzione di immagini ad alta risoluzione.
Tinta metallizzata: Stampa metallizzata senza costi aggiuntivi.
BR: finitura brillante
Glow in the dark: rendi il tuo marchio visibile anche al buio
Finitura metallica: Crea effetti, immagini o stenci metallici.
Finitura olografica: Trasforma il tuo logo in un'immagine tridimensionale con gli ologrammi.
Matte: finitura opaca
UV: finitura lucida
Sandy: effetto sabbia con texture granulata
Digital: Alta definizione - stampa in digitale in quadricromia, 360° gradi su tutta la lunghezza del corpo.
britePix™: Il messaggio può essere stampato a colori con l'eccezionale risoluzione fotografica che assicura un'impressione durevole e vibrante del vostro logo
britePix™ Texture
britePix™ Texture è un salto di qualità nel nostro concetto di stampa britePix™ - ora non solo puoi vedere il colore pieno, ma puoi anche toccarlo!
britePix™ personalisation
Personalizzazione britePix™. Personalizza ogni unità dello stesso ordine britePix™.

Abbreziature

- SP = Serigrafia
LE = Incisione laser
4CP = Stampa in quadricromia
HS = Stampa a caldo
DB = Bassorilievo
PD = Stampa a tampone
DT = Trasferimento digitale
DG = Digitale
BP = britePix™
BP Texture = britePix™ Texture
OT = transfer in offset
MOQ = Quantità minima d'ordine

Colori d'inchiostro:

- nero verde chiaro
azzurro verde
blu rosa
rosso viola
fluo

Modalità di scrittura

- Penna a sfera
Penna Stilografica
Evidenziatore
Pennarello
Portamine
Matita
Roller
Gel
Finestyle
Tipp-Ex®

BIC® Easy-Glide system option Offre il 35% di scrittura più fluida e corposa rispetto agli inchiostri standard.

Altri simboli

- Mix&Match: Centinaia di colori dei componenti di produzione degli strumenti di scrittura per una personalizzazione completa.
PMS Service: Scegli il colore PMS per le finiture che meglio si adatta al tuo logo
QR CODE: scannizza il QR code e guarda il video
48 hour: Servizio in 48 ore disponibile
Mobius loop: Il prodotto contiene materiale riciclato.
Renewable Resource: Prodotto composto da materiale ecologico, realizzato con materiali naturali di conifere rinnovabili (polimeri cellululosici).
APP: Scarica la app di BIC Graphic e scannizza le pagine che abbiano quest'icona.
Paese d'origine
Nuovi / Nuovi colori
Guarda!: Lasciati sorprendere dalle finiture di questo prodotto.
Tocca!: Lasciato sorprendere dalla sensazione al tatto di questo prodotto.
Morbidlo al tatto! Toccare questo prodotto sarà una sorpresa.
EN 13869: Normativa europea per accendini sulla sicurezza dei bambini.
ISO 22702: Questa normativa certifica la qualità di tutti i nostri accendini.
ISO 9994: Norme di sicurezza internazionali per gli accendini.
Sticky Notes: Numero di fogli.
Notebooks: Numero di fogli.
Informazioni sul packaging
BIC® Boy: icónico BIC Boy è impresso qui
Strisca lubrificante
Numero di lame
BIC® Mega Lighter: Utilizzo quotidiano del BIC® Mega Lighter
Numero di accensioni
Confezione di gel da rasatura da 10 ml, disponibile solo per Austria, Belgio, Francia, Germania, Italia, Lussemburgo, Paesi Bassi, Portogallo, Romania, Spagna, Svizzera e Regno Unito.
Exclusivo Prodotti che sono esclusivi all'interno del nostro catalogo.
Bluetooth®
Frequenza
Impedenza
Sensibilità
Diametro magnete
Senza cavo
Autonomia della batteria
Lunghezza cavo
Resistente all'acqua
Potenza
A prova di urti
Punti per pollice
Entrata/uscita alimentazione
Risoluzione video
Risoluzione camera
Obiettivo camera
Dimensione schermo

Dimensioni

Le dimensioni pubblicate relative a ciascun prodotto corrispondono alla sua dimensione massima indipendentemente dalla posizione del disegno.

Symbols & Abbreviations

PRINTING TECHNIQUES



Puffy glitter
Coloured glitter texture.



Puffy Printing
Highlighted personalisation giving a relief effect to your logo.



4-Colour Process
Allows reproduction of high-resolution images. Ideal for reproducing photos.



Metallic Ink
Metallic imprint inks at no charge. Available in blue, green and pink colours.



BR
Brilliant finish.



Glow in the dark
Make your brand glow even in the dark.



Metallic Finish
Create metallic effects on images and backgrounds.



Holographic Finish
Convert your logo into a three-dimensional



Matte
Matte finish.



UV
High gloss finish.



Sandy
Sandpaper effect with a granulated texture.



Digital
High-definition 4-colour process. 360° degrees and full length of the barrel/body.



britePix™
Full-colour with photographic excellence, producing a durable imprint that ensures lasting impressions of your logo.



britePix™ Texture
britePix™ Texture is a fresh new addition to our britePix™ concept: now you don't just see the full colour – you can feel it!



britePix™ personalisation
Personalise each unit within the same britePix™ order.

ABBREVIATIONS

SP = Screen printing
LE = Laser engraving
4CP = 4-colour process
HS = Hot stamping
DB = Debossing
PD = Pad printing
DT = Digital transfer
DG = Digital
BP = britePix™
BP Texture = britePix™ Texture
OT = Offset transfer
MOQ = Minimum order quantity

INK COLOURS

● Black Ink ● Light Green Ink
● Light Blue Ink ● Dark Green Ink
● Dark Blue Ink ● Pink Ink
● Red Ink ● Purple Ink
● Fluo Ink



BIC® Easy-Glide system option
Offers 35% smoother and bolder write-out than our standard ink.

WRITING MODES



M Medium
F Fine
Ballpen



FP Fountain Pen



MP Mechanical Pencil
Ø 0,7 mm



FS Finestyle



PC Pencil



HL Highlighter



R Roller Ball



T Tipp-Ex®
6 m



MK Marker



G Gel

OTHER SYMBOLS



Mix&Match
Hundreds of colours of components in stock of writing instruments for full personalisation.



PMS Service
Choose the PMS colour for trims that best matches your logo.



QR code
Scan QR code and watch the video.



48-Hour
48-Hour Printing Service



Möbius Loop
Product contains recycled material.



Renewable Resource
Product made with eco-friendly material manufactured using natural, renewable softwood materials (cellulosic polymers).



Country of Origin



BIC Graphic App
Download the BIC Graphic App and scan the pages that have this icon.



NEW / New colours



See!
Be surprised by this product finishes.



Touch!
Be surprised by this product touch.



EN 13869
European Child Resistant Regulation for lighters.



ISO 22702
This standard certifies the quality of all utility lighters.



ISO 9994
International Safety Standards for lighters.



Sticky Notes
Number of sheets.



Notebooks
Number of sheets.



250
± 5,3 Kg
Packaging Information



BIC® Boy
Iconic BIC® Boy is embossed here



Lubricating strip



Number of blades



BIC® Mega Lighter
Usage of BIC® Mega Lighter in everyday occasion.



Up to 1400
Number of flames



Shaving gel tube 10ml only available for Austria, Belgium, France, Germany, Italy, Luxembourg, The Netherlands, Portugal, Romania, Spain, Switzerland and UK.



Exclusive
Exclusive items only available through our catalogue.



Bluetooth®



Frequency



Impedance



Sensitivity



Magnet diameter



Wireless



Battery autonomy



Cable length



Waterproof



Power



Shockproof



Dot per inch



Power entrance/exit



Video resolution



Camera resolution



120°
Camera objective



1,5"
Screen dimension

DIMENSIONS Dimensions published of each product correspond to its maximum size, regardless of the drawing position.

Product Index

ITEM NAME	PAGE	ITEM NAME	PAGE	ITEM NAME	PAGE
Writing instruments					
BIC® 4 Colours	88	BIC® Wide Body™ Chrome	78	BIC® J25 Digital Lighter	203
NEW BIC® 4 Colours 3+1™	97	BIC® Wide Body™ Digital	76	BIC® J25 Lighter	200
BIC® 4 Colours britePix™	94	BIC® Wide Body™ Chrome Digital	79	BIC® J25 Lighter britePix™	202
BIC® 4 Colours Fashion	90	BIC® Wide Body™ Digital Ecolutions®	77	BIC® J26 Digital Lighter	207
BIC® 4 Colours Fashion britePix™	94	BIC® Wide Body™ Ecolutions®	75	BIC® J26 Lighter	206
BIC® 4 Colours Fine	93	BIC® Wide Body™ Metal	105	BIC® J38 Digital Lighter	211
BIC® 4 Colours Fluo	95	BIC® Wide Body™ Metal Grip	104	BIC® J38 Lighter	210
BIC® 4 Colours Mini	89	BIC® Wide Body™ Mini Digital	80	BIC® J39 Digital Lighter	213
BIC® 4 Colours Shine	92	BIC® Wide Body™ Mini Digital Chrome	81	BIC® J39 Lighter	212
BIC® 4 Colours Stylus	96	BIC® XS Finestyle	115	BIC® Mega Lighter	215
NEW BIC® 4 Colours Sun	91	BIC® XS Finestyle britePix™	115	BIC® Mega Lighter britePix™	215
BIC® Atlantis®	83	Conté® by BIC® Colouring Set	139	BIC® Pocket Ashtray	225
BIC® Atlantis® Clear	83	Conté® set of 6 colouring pencils	137	NEW BIC® Pocket Ashtray Kraft	225
BIC® Atlantis® Gel	109	Tipp-Ex® Mini Pocket Mouse britePix™	141	BIC® Styl'it Fashion Case	223
BIC® Attriant®	103	Other Writing instruments			
BIC® Brite Liner® Grip	122	Basic pen	143	BIC® Styl'it Fashion Case britePix™	223
BIC® Brite Liner® Grip XL	123	Chrome Curved pen	148	BIC® Styl'it Luxury Case	219
BIC® Citation	100	Click pen	144	BIC® Styl'it Luxury Case britePix™	219
BIC® Clic Ecolutions®	85	Curved Grip pen	146	BIC® Styl'it Luxury Case Metallic	220
BIC® Clic Gold Ecolutions®	85	Curved pen	145	BIC® Styl'it Luxury Case Neon	218
BIC® Clic Stic	52	Sleek Stylus Executive pen	151	BIC® Styl'it Luxury Case Neon britePix™	218
BIC® Clic Stic Digital	56	Sleek Stylus Matt pen	150	BIC® Styl'it Luxury Case Soft	220
BIC® Clic Stic Digital Ecolutions®	57	Sleek Stylus pen	149	Shavers	
BIC® Clic Stic Ecolutions®	54	Striped Grip pen	147	BIC® Comfort 2 Lady	233
BIC® Clic Stic Mini Digital	56	White Striped Grip pen	147	BIC® Comfort Twin	229
BIC® Clic Stic Softfeel®	55	SPROUT™			
BIC® Clic Stic Stylus	58	Sprout™ pencil	153	BIC® Flex3	230
BIC® Clic Stic Stylus Digital	59	Sticky notes			
BIC® Evolution® Digital Ecolutions®	131	BIC® 50 mm x 75 mm Adhesive Notepads	157	BIC® Flex4 Comfort	231
BIC® Evolution® Ecolutions®	130	BIC® 50 mm x 75 mm Adhesive Notepads Ecolutions®	165	BIC® Pure 3® Lady	234
BIC® Evolution® Metallic Digital Ecolutions®	131	BIC® 68 mm x 75 mm Adhesive Notepads	158	BIC® Soleil® Bella® Lady	235
BIC® Evolution® Ecolutions® Colouring set	138	BIC® 68 mm x 75 mm Adhesive Notepads Ecolutions®	165	Bags	
BIC® Evolution® Ecolutions® set of 6 colouring pencils	135	BIC® 75 mm x 127 mm Non-Adhesive Scratch Pad	176	BIC® Classic Backpack	240
BIC® Great Eraser White Board Marker	119	BIC® 75 mm x 75 mm Adhesive Notepads with Flag Booklet	170	BIC® Drawstring Backpack	239
BIC® Grip Roller	113	BIC® 75 mm x 75 mm Adhesive Notepads	159	BIC® Multi-use Pouch	241
BIC® Grip Roller Gold	113	BIC® 75 mm x 75 mm Adhesive Notepads Ecolutions®	165	TnB®	
BIC® Intensity® Gel Clic	111	BIC® 75 mm x 75 mm Booklet	168	TnB® 4K Action Camera	265
BIC® M10® Clic	30	BIC® 96 mm x 152 mm Non-Adhesive Scratch Pad	177	NEW TnB® Active Noise Reduction headphones	250
BIC® Mark-It Permanent Marker	120	BIC® 101 mm x 101 mm Adhesive Notepads	163	NEW TnB® ART speaker	254
BIC® Matic®	126	BIC® 101 mm x 101 mm Adhesive Notepads Ecolutions®	165	TnB® Be colour headphones	249
BIC® Matic® Ecolutions®	127	BIC® 101 mm x 152 mm Adhesive Notepads	164	TnB® Flat Bluetooth® earphones	246
BIC® Matic® Grip	129	BIC® 101 mm x 75 mm Adhesive Notepads	161	TnB® HD Action Camera	264
BIC® Matic® Quartz	128	BIC® 101 mm x 75 mm Adhesive Notepads Ecolutions®	165	TnB® Headphones	248
BIC® Media Clic	40	BIC® 101 mm x 152 mm Adhesive Notepads Ecolutions®	165	TnB® Juke speakers 2.0	253
BIC® Media Clic Digital	43	BIC® 101 mm x 75 mm Adhesive Notepads	161	NEW TnB® Legend headphones	247
BIC® Media Clic Ecolutions®	42	BIC® 101 mm x 75 mm Alternating Sheet Imprint	161	TnB® Live in earphones	244
BIC® Media Clic Grip	45	BIC® 101 mm x 75 mm Alternating Sheet Imprint Ecolutions®	165	TnB® Lumy Wired mouse	258
BIC® Media Clic Grip Digital	47	BIC® 101 mm x 75 mm Booklet	169	TnB® Mini Wireless mouse	259
BIC® Media Clic Grip Digital Ecolutions®	48	BIC® 101 mm x 75 mm Mini Pencil Booklet	171	NEW TnB® Rainbow mouse	257
BIC® Media Clic Grip Ecolutions®	46	BIC® 150 mm x 150 mm Booklet	174	TnB® Shine Bluetooth® headphones	251
BIC® Media Clic Premium	49	BIC® 150 mm x 150 mm Booklet with Pen Loop	175	NEW TnB® Slim power bank 6000 mAh	263
BIC® Permanent Marker Ecolutions®	121	BIC® Clic Stic Mini Digital Organiser	173	TnB® Sport Bluetooth® headphones	252
BIC® Plastidecor® Colouring Set	138	BIC® Clic Stic Mini Organiser	172	TnB® Sport Bluetooth® speaker ball	255
BIC® Plastidecor® set of 6 crayons	133	BIC® Flag Booklet	167	TnB® Sport earphones with mic	245
BIC® Protrusion Grip	106	BIC® Medium Adhesive Die Cut Notepads	162	TnB® Stone power bank 4000 mAh & 6600 mAh	261
BIC® Rondo Evo	102	BIC® Medium Adhesive Die Cut Notepads Ecolutions®	165	NEW TnB® Ultra-slim power bank 4000 mAh	262
BIC® Rondo Evo Soft	102	BIC® Small Adhesive Die Cut Notepads	160	NEW TnB® Ultra-slim power bank 4000 MFi	263
BIC® Round Stic®	34	Notebooks			
BIC® Round Stic® Digital	37	BIC® Notebooks Chipboard Cover	184	TnB® Vintage Bluetooth® speaker	256
BIC® Round Stic® Digital Ecolutions®	37	BIC® Notebooks Chipboard Cover britePix™	185	SKROSS®	
BIC® Round Stic® Ecolutions®	36	BIC® Notebooks Dual A5	181	SKROSS® Euro USB Charger	268
BIC® Slim Metal	101	BIC® Notebooks Dual A6	181	SKROSS® Midget Dual USB Car Charger	267
BIC® Style	27	BIC® Notebooks Plastic Cover	182	SKROSS® Pro Light USB	270
BIC® Style Clear	27	BIC® Notebooks Plastic Cover britePix™	183	SKROSS® World Adapter MUV USB	271
BIC® Super Clip	62	Office Accessories			
BIC® Super Clip Advance	68	NEW Classic	188	SKROSS® World to Europe USB	269
BIC® Super Clip Advance britePix™	69	NEW Sublimation Mug	188	Packaging	
BIC® Super Clip Advance britePix™ Digital	71	NEW Laser Mug	189	BIC® Cotton drawstring pouch	278
BIC® Super Clip Advance Digital	70	Mouse Pad	187	Black Two-Piece Gift Box	277
BIC® Super Clip britePix™	64	Lighters			
BIC® Super Clip britePix™ Digital Ecolutions®	67	NEW BIC® 3D Case	224	Black Velvet Pouch	276
BIC® Super Clip britePix™ Ecolutions®	65	BIC® Aluminium Flat Case	221	Carton Black & Silver colour gift box	276
BIC® Super Clip britePix™ Digital	66	BIC® Aluminium Flat Case britePix™	221	Cello Wrap	274
BIC® Super Clip Digital	66	BIC® Clip Case britePix™	222	Count Box for 10 units	260
BIC® Super Clip Digital Ecolutions®	67	BIC® J23 Digital Lighter	205	Frosted Pouch	275
BIC® Super Clip Ecolutions®	65	BIC® J23 Lighter	204	Hinged Gift Box	279
BIC® Tri-Tone Twist	107	GENERAL INFORMATION			
BIC® Triumph 537R	110	www.bicgraphic.eu			
BIC® Velleda® White Board Marker Fine	118	288			
BIC® Visa® Colouring Set	138				
BIC® Visa® set of 6 felt pens	134				
BIC® Wide Body™	74				

Colour table

Nuancier de couleurs / Gama de colores / Farbindex / Tavolozza dei colori

01 1E	10	blanc blanco weiss bianco	57	blanc opaque blanco opaco opak weiss bianco opaco	51	transparent transparente transparentweiss trasparente	69 2E	blanc glacé blanco frosted gefrostet weiss bianco frosted	3C	blanc perlé blanco perla perlweiß bianco perla
12		jaune amarillo opak gelb giallo	8G 23	jaune light amarillo light hellgelb giallo chiaro	2F	jaune acide amarillo ácido Säure Gelb giallo acido	63	jaune frost amarillo frosted gefrostet gelb giallo frosted	71	orange glacé naranja frosted gefrostet orange arancio frosted
92		orange clear naranja clear transparentorange arancio trasparente	4D	jaune clear amarillo transparente Transparentes Gelb giallo clear	8D	jaune pastel amarillo pastel pastelgelb giallo pastello	1G	orange fluo naranja ácido säureorange arancio acido	10 22	orange naranja opak orange arancio
03 8E	20	rouge rojo opak rot rosso	4G	rouge métallisé rojo metálico metallicrot rosso metallizzato	87	rouge clear rojo clear transparentrot rosso trasparente	08 71	bordeaux burdeos burgunderrot bordeaux	14	rose rosa rosa rosa
3H		corail rose rosa coral korallenrosa rosa corallo	1P 27	rose fluo rosa ácido säurerosa rosa acido	5C	magenta fucsia pink fucsia	95	rose clair rosa clear transparentrosa rosa trasparente	2C	rose métallisé rosa metálico metallicipink rosa metallizzato
26 03		or oro gold oro	4B	violet glacé violeta fros ted gefrostet violet viola frosted	2D	lilas violeta lila viola	84	pourpre pastel púrpura pastel pastellila viola pastello	93 93	pourpre clair púrpura clear transparentlila viola trasparente
39		pourpre glacé púrpura frosted gefrostet lila viola frosted	13 25	pourpre púrpura opak lila viola	7G	violet métallisé violeta metálico metallilila viola metallizzato	3D	bleu caraïbe azul caribeño karibikblau azzurro caraibico	24 53	bleu clair azul claro hellblau azzurro chiaro
67 67		bleu glacé azul frosted gefrostet blau azzurro frosted	86	bleu clair azul clear transparentblau azzurro trasparente	83	bleu pastel azul pastel pastelblau azzurro pastello	34 34	bleu métallique azul metálico metallilblau blu metallizzato	1D	bleu foncé métallisé azul metálico oscuro metallil Dunkelblau blu scuro metallizzato
04		bleu azul opak blau blu	40	bleu nuit glacé azul oscuro frosted gefrostet dunkelblau blu frosted	89	bleu marine clair azul oscuro clear transparentdunkelblau blu trasparente	50	bleu royal azul real königsblau blu royal	07 10E	bleu marine azul marino opak marineblau blu
25 52		bleu nuit azul oscuro dunkelblau azzurro scuro	85	vert pastel verde pastel pastelgrün verde pastello	68	vert glacé verde frosted gefrostet grün verde frosted	59 29	vert pomme verde manzana apfelgrün verde mela	2G	vert fluo verde ácido säuregrün verde acido
88 88		vert clair verde clear transparentgrün verde trasparente	6C	vert herbe verde hierba grasgrün verde mela	82	vert foncé glacé verde oscuro frosted gefrostet dunkelgrün verde scuro frosted	05 60	vert verde opak grün verde	20 7E	vert foncé verde oscuro opak dunkelgrün verde scuro
2B		kaki jungla opak dschungelgrün kaki	3B	kaki glacé jungla frosted gefrostet dschungelgrün kaki frosted	29	bronze oro viejo bronze oro brunito	47	argent plata silber argento	18	métal metal metall metallizzato
06		gris foncé gris grau grigio	27	gris foncé gris oscuro dunkelgrau grigio scuro	02 3E	noir negro opak schwarz nero	4A	pure argent plata silber argento puro	75	argent métallisé plata metálico metallilsilber argento metallizzato
5A		bleu ardoise azul pizarra schieferblau blu ardesia	7A	gris ombre gris oscuro anthrazit grigio	35	chrome cromo premiumsilber cromato	8A	bronze bronce bronce bronzio	8H	gris foncé frost gris oscuro clear transparentesdunkelgrau grigio scuro trasparente

The colours shown above are for reference only. Actual colour may vary slightly depending on the product / Ces couleurs sont de nature indicative et non contractuelle. Leur rendu peut donc varier en fonction de la matière sur laquelle elle sont apposées / Los colores arriba indicados, son sólo una referencia. El color real puede variar dependiendo del producto / Die oben angeführten Farben dienen ausschließlich der Veranschaulichung. Leichte Abweichungen können je nach Produkt entstehen / I colori esposti sopra sono solo un riferimento. I colori reali possono essere leggermente diversi, a seconda del prodotto.



graphic

www.bicgraphic.eu

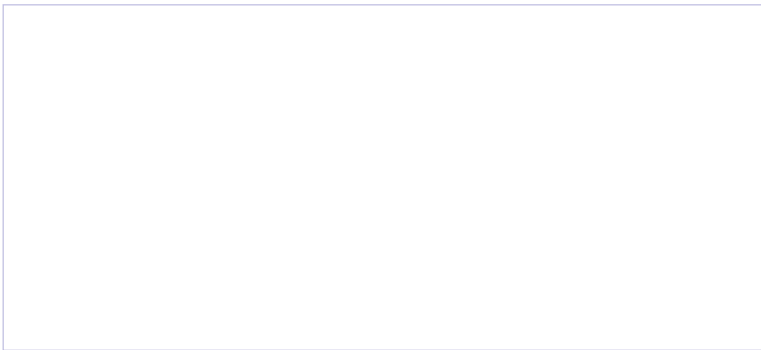

6,00 €; 4,65 GBP; 56 SEK; 45 DKK; 49 NOK; 24 PLN; 7,8 CHF
ISO 9994 & EN13869 Lighters / Briquets / Encendedores / Feuerzeuge / Accendini

©2018 BIC Graphic Europe



PRINTED IN EUROPE